

Technical Drawing



Lecture 4. Distances and angles

Distance between two points I

- **Definition:** is the length of the segment that joins both points.
- **Aim:** find the **true** length of the segment that joins both points.

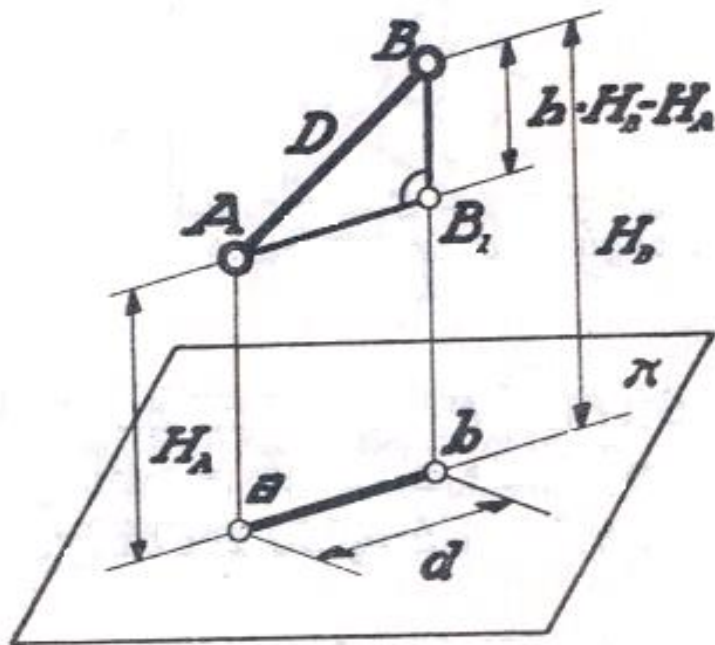

Distance between two points I

- **Definition:** is the length of the segment that joins both points.
- **Aim:** find the **true** length of the segment that joins both points.

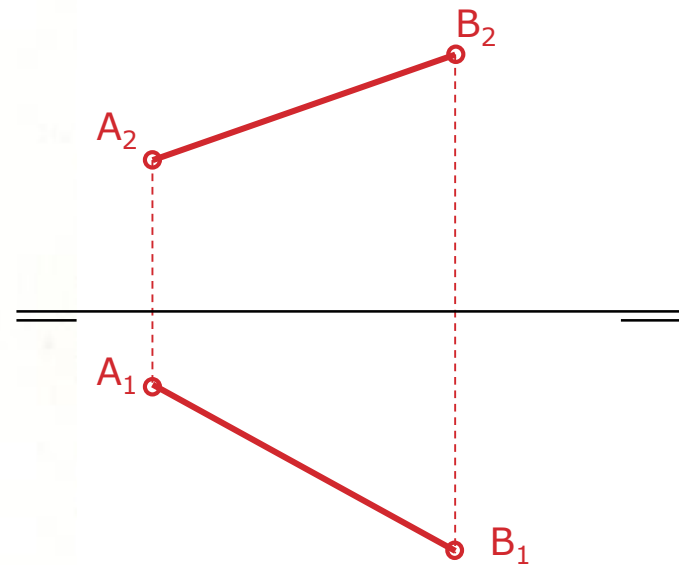
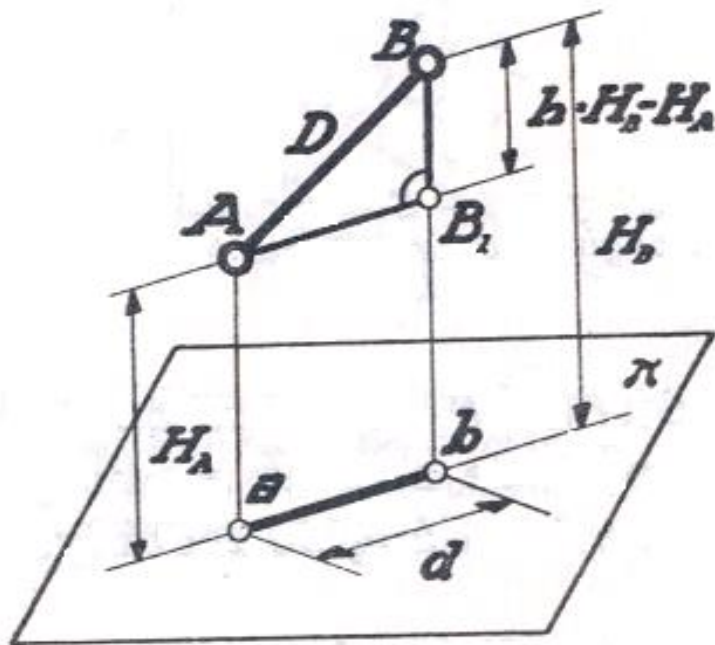

Distance between two points I

- **Definition:** is the length of the segment that joins both points.
- **Aim:** find the **true** length of the segment that joins both points.

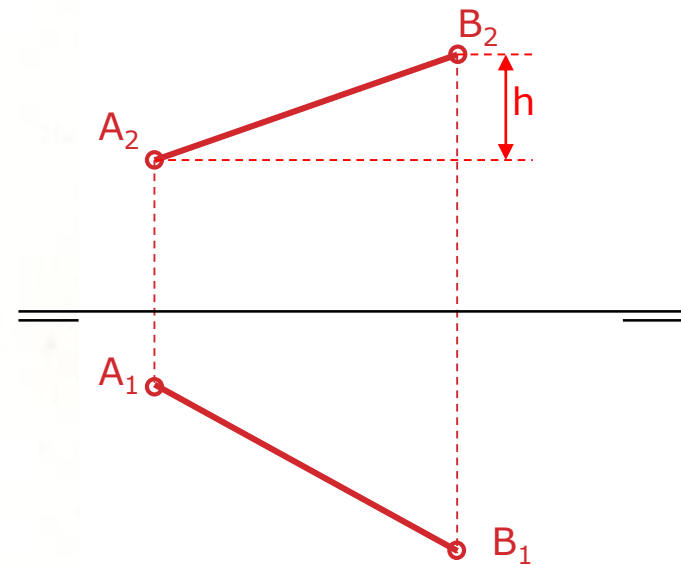
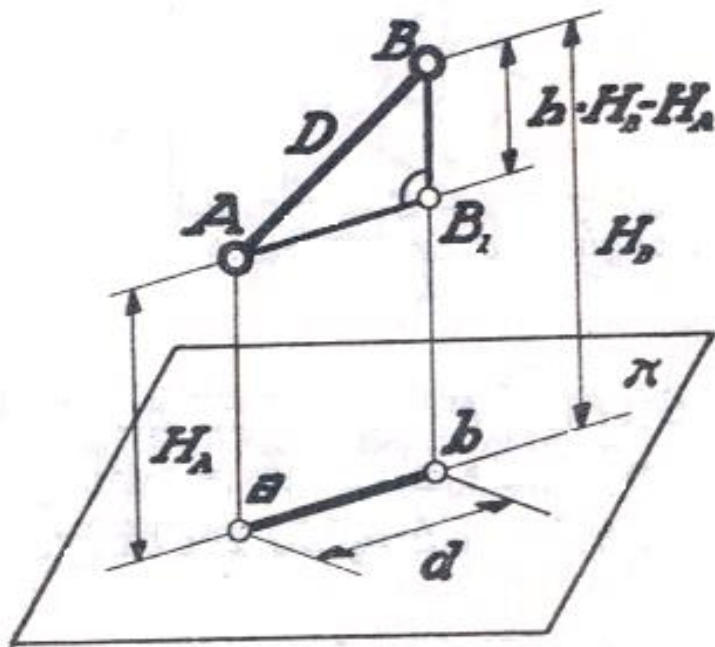

Distance between two points I

- **Definition:** is the length of the segment that joins both points.
- **Aim:** find the **true** length of the segment that joins both points.

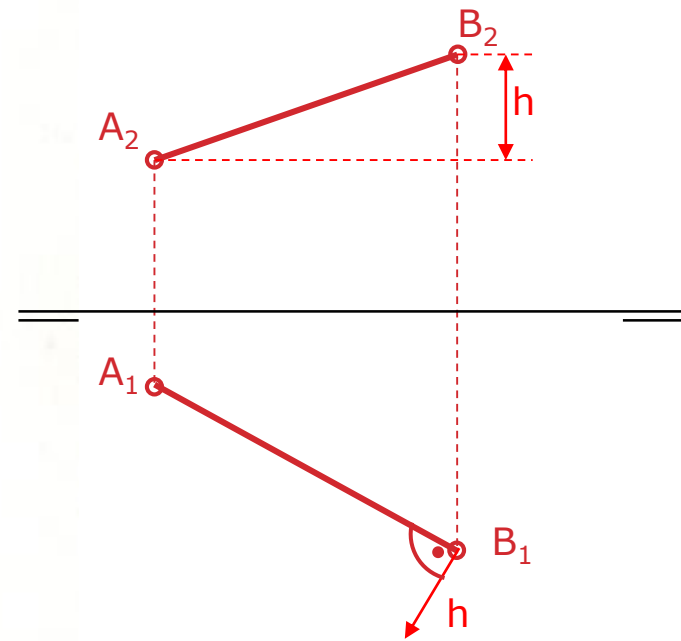
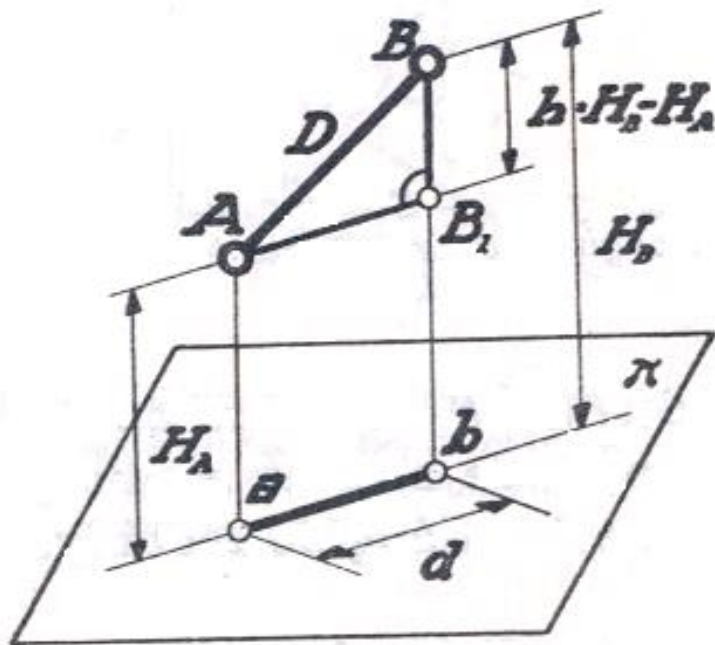

Distance between two points I

- **Definition:** is the length of the segment that joins both points.
- **Aim:** find the **true** length of the segment that joins both points.

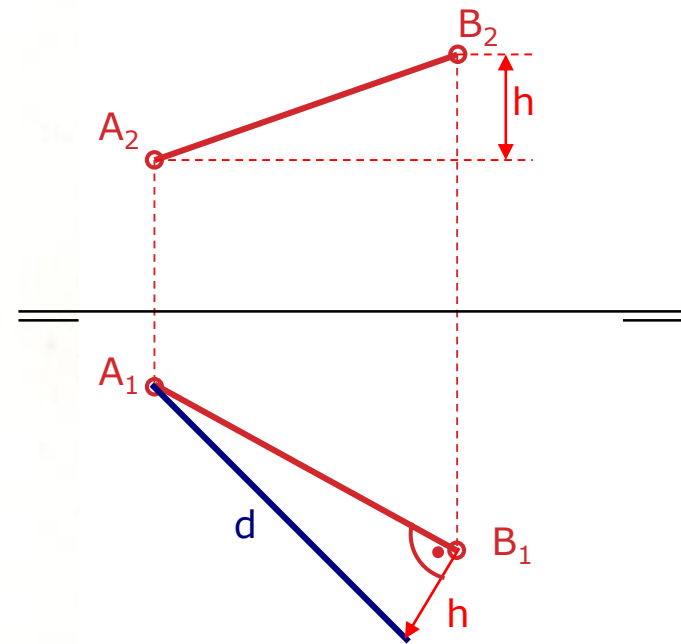
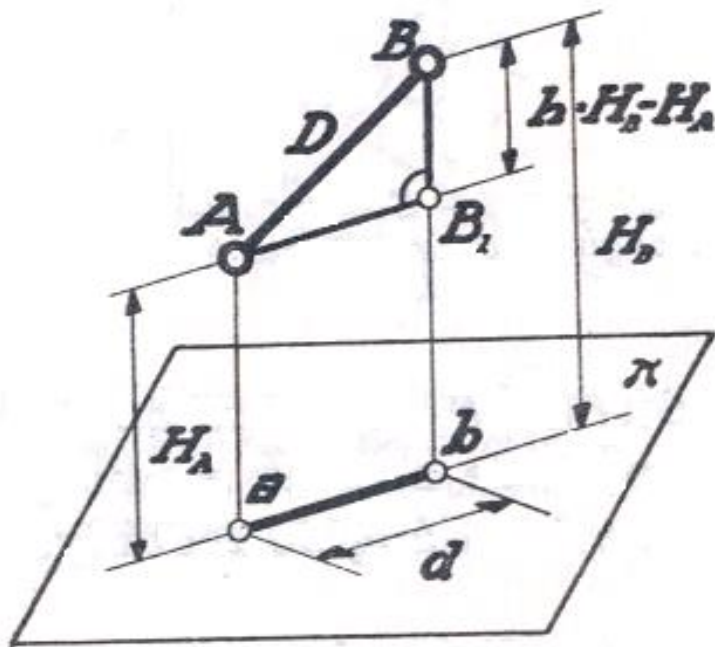

Distance between two points I

- **Definition:** is the length of the segment that joins both points.
- **Aim:** find the **true** length of the segment that joins both points.

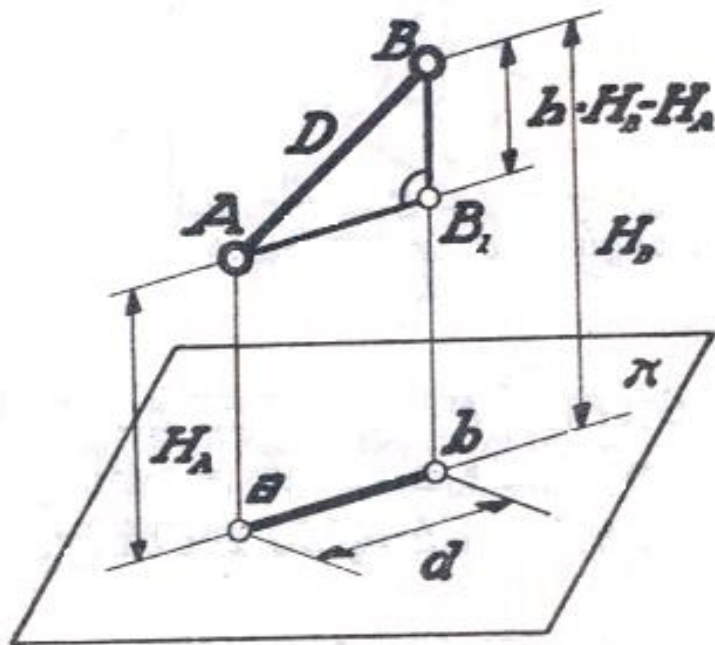

Difference in heights

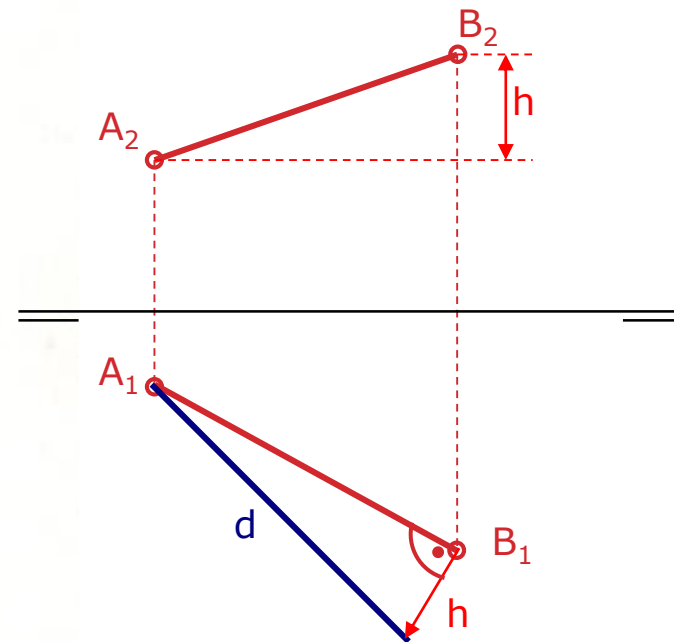

Distance between two points II

Difference in depth

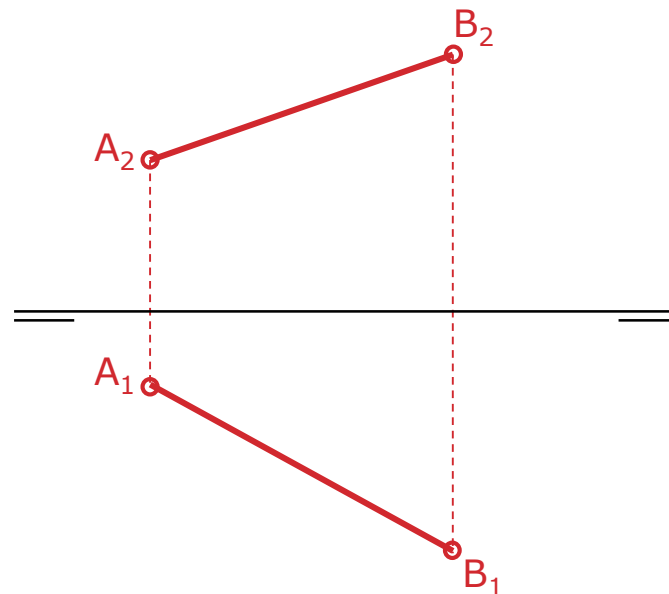

Distance between two points II

Difference in depth

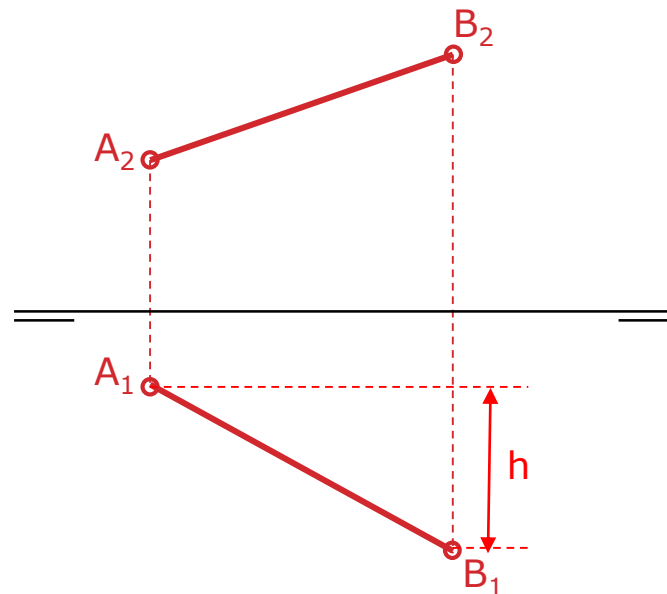

Distance between two points II

Difference in depth

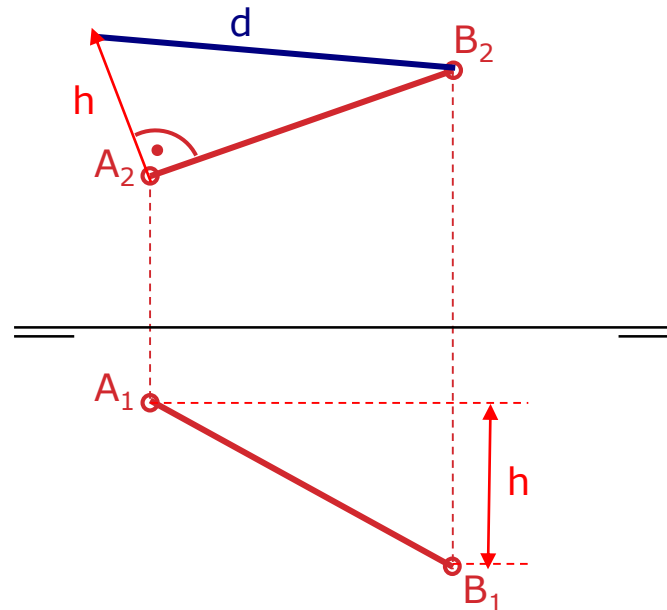

Distance between two points III

Fold line method applied to a plane that contains segment AB

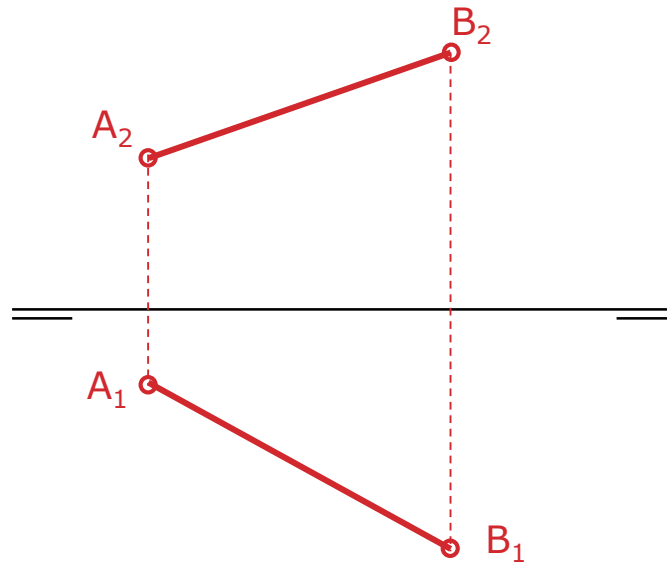

Distance between two points III

Fold line method applied to a plane that contains segment AB

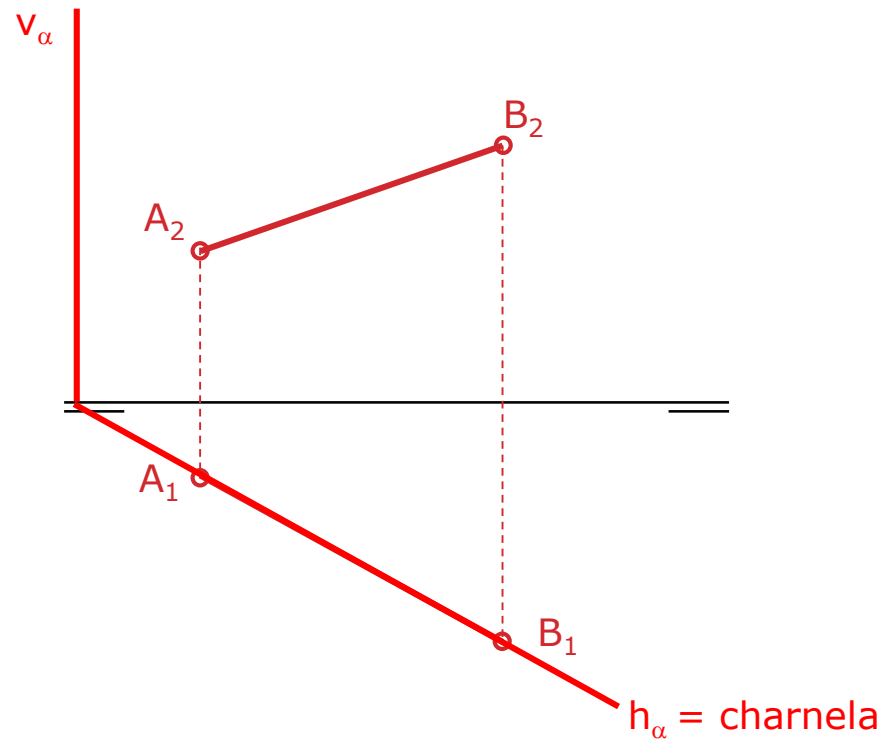

Distance between two points III

Fold line method applied to a plane that contains segment AB

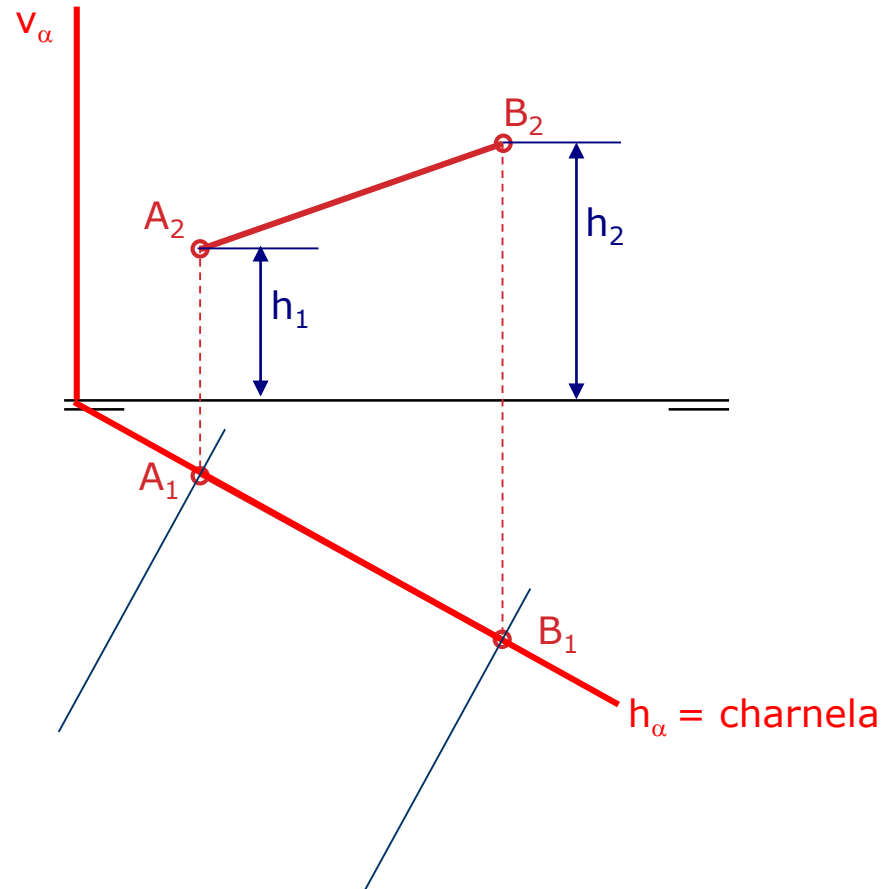

Distance between two points III

Fold line method applied to a plane that contains segment AB

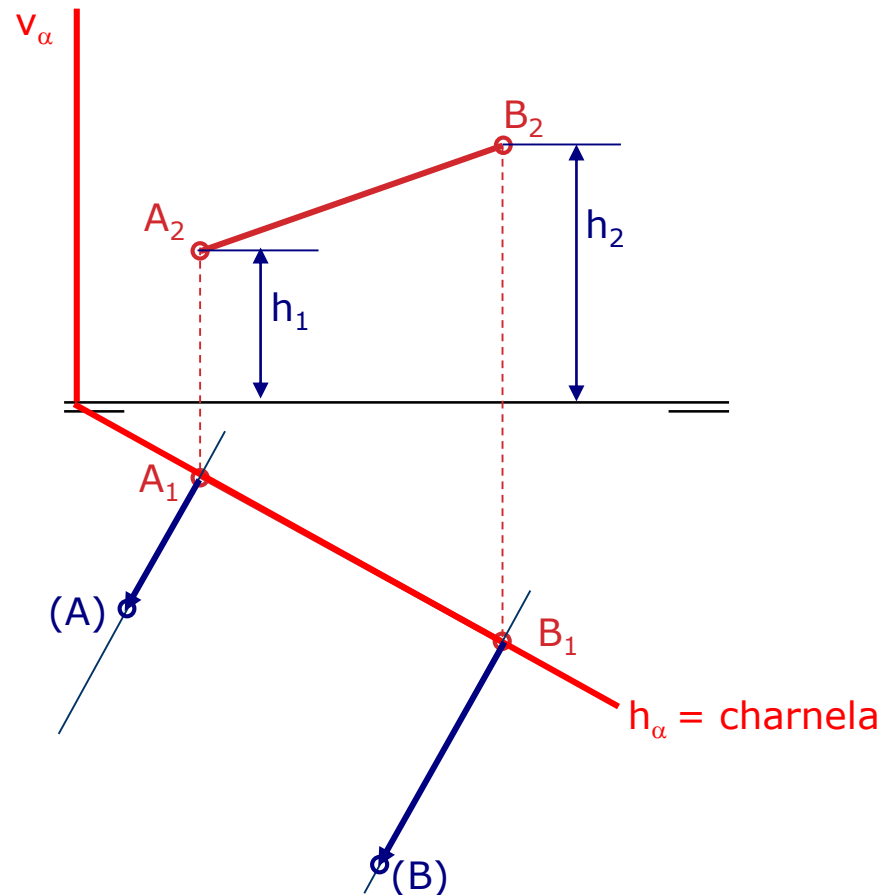

Distance between two points III

Fold line method applied to a plane that contains segment AB

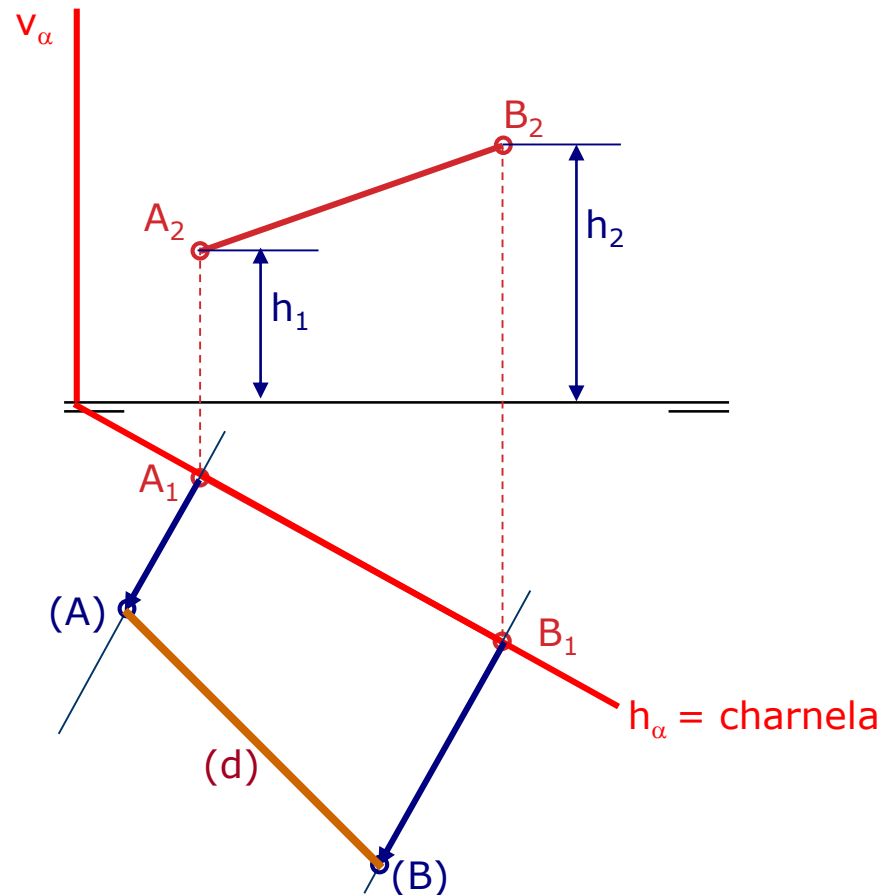

Distance between entities I

- **Definition:** is the minimum distance between the points of both **elements**.
 - Distance between **a point and a line**.
 - Distance between **two parallel planes**.
 - Distance between **two parallel lines**.
 - Distance between **two crossing lines**.

Distance between a point and a line



Distance between a point and a line

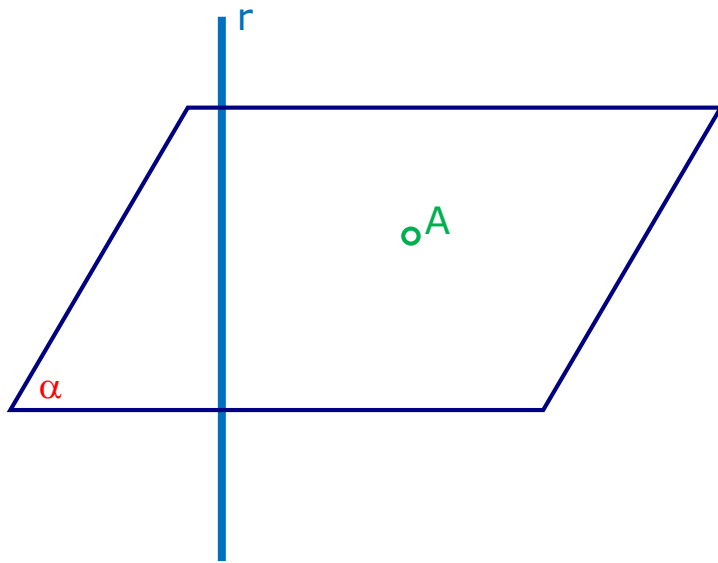

1. Plane $\alpha \perp$ to r and contains A

Distance between a point and a line

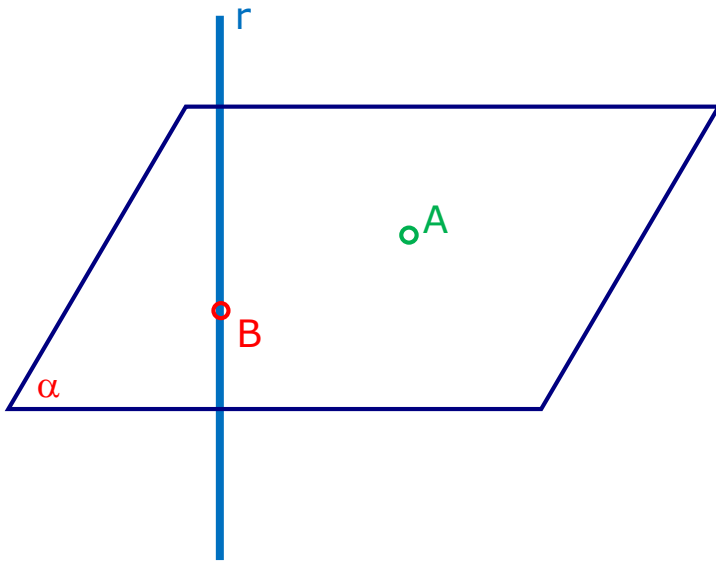

1. Plane $\alpha \perp$ to r and contains A
2. Intersection of line r with plane α

Distance between a point and a line

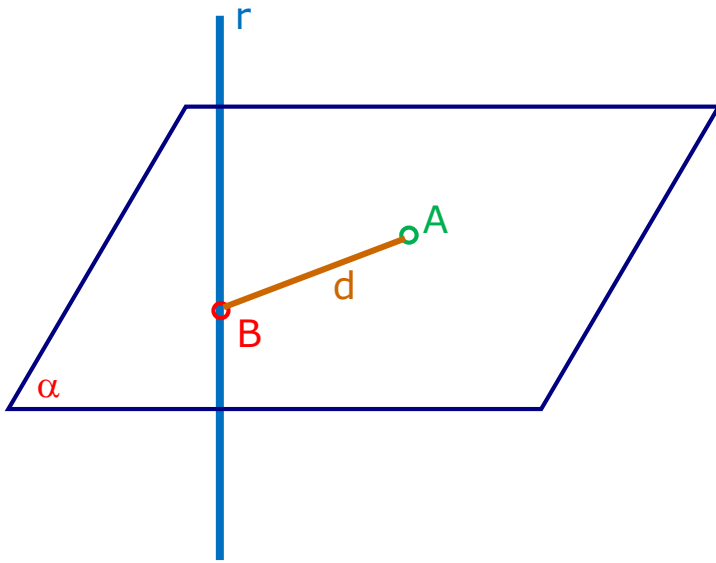

1. Plane $\alpha \perp$ to r and contains A
2. Intersection of line r with plane α

Distance between a point and a line

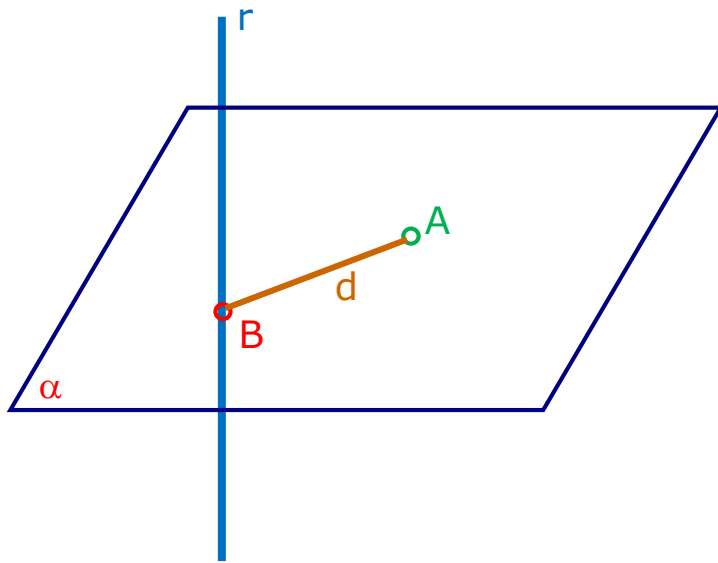

1. Plane $\alpha \perp$ to r and contains A
2. Intersection of line r with plane α

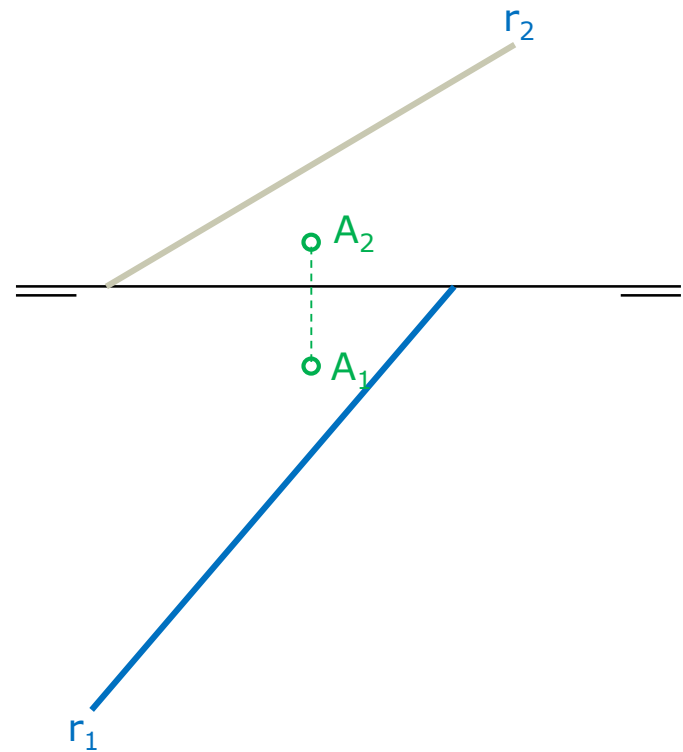

Distance between a point and a line

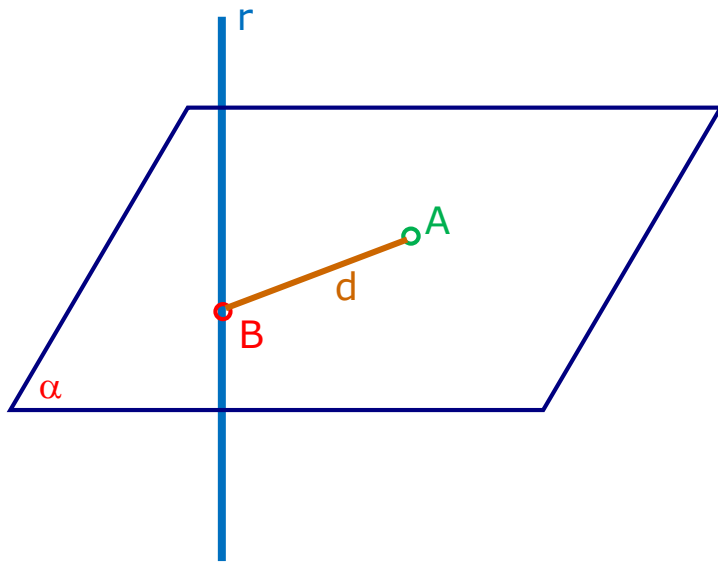

1. Plane $\alpha \perp$ to r and contains A
2. Intersection of line r with plane α

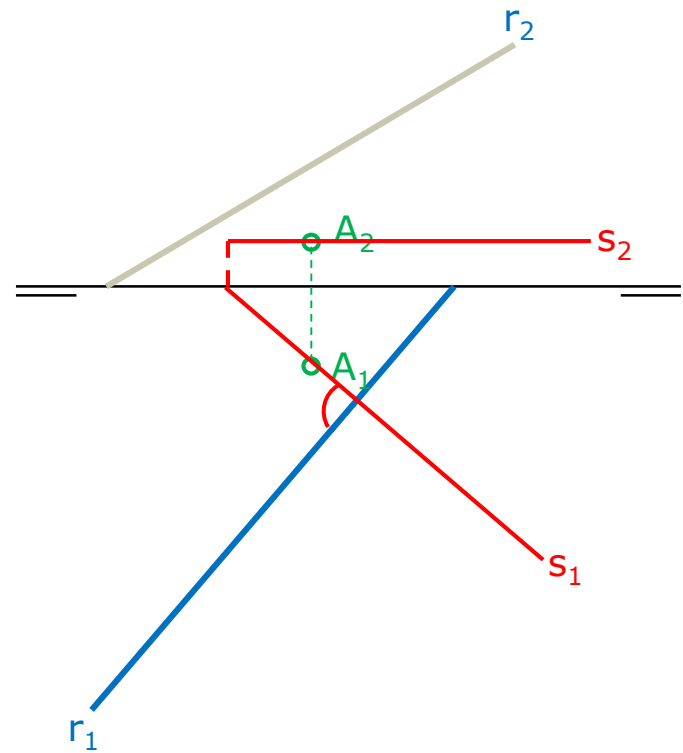

Distance between a point and a line

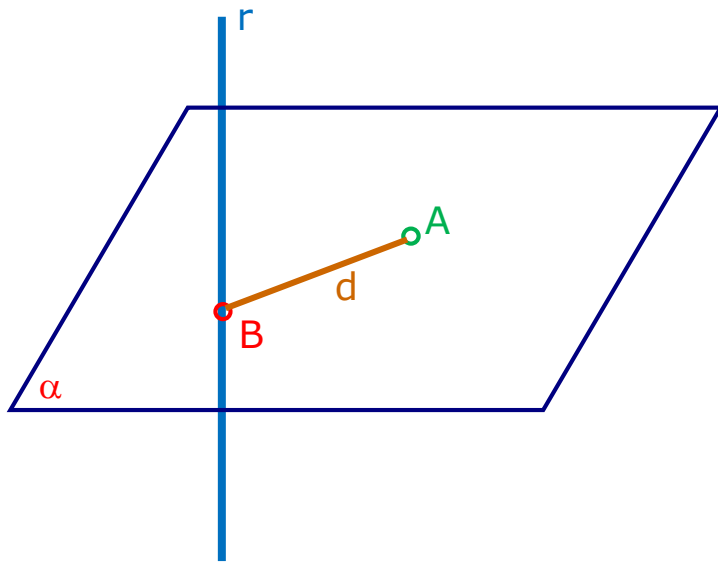

1. Plane $\alpha \perp$ to r and contains A
2. Intersection of line r with plane α

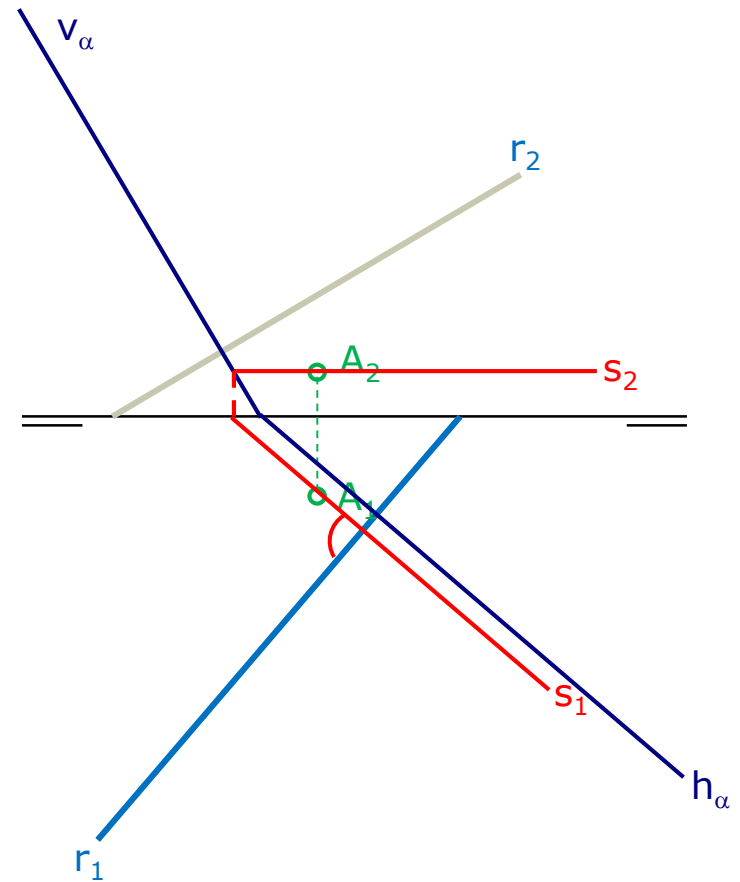

Distance between a point and a line

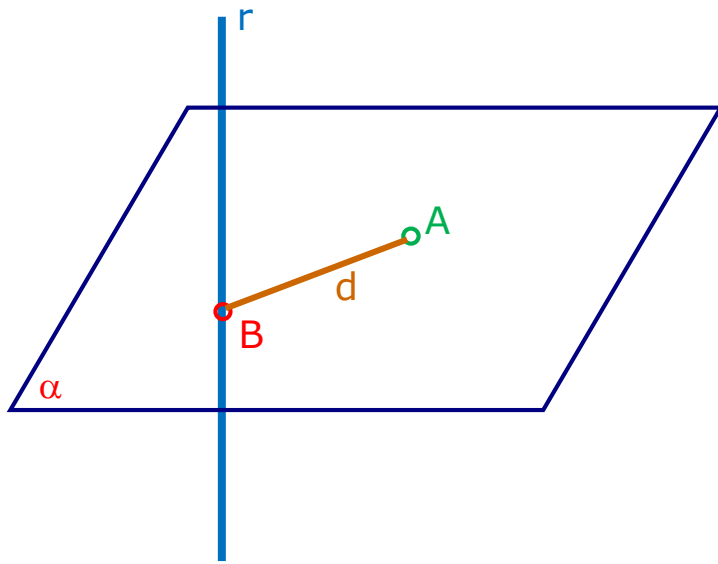

1. Plane $\alpha \perp$ to r and contains A
2. Intersection of line r with plane α

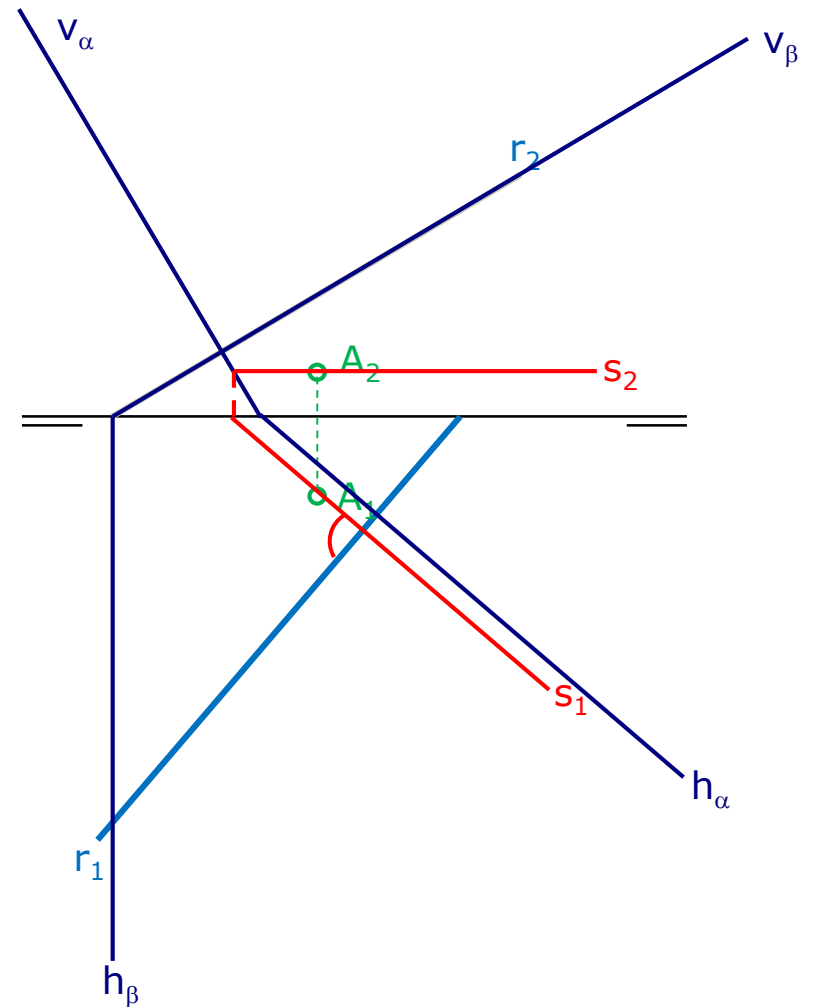

Distance between a point and a line

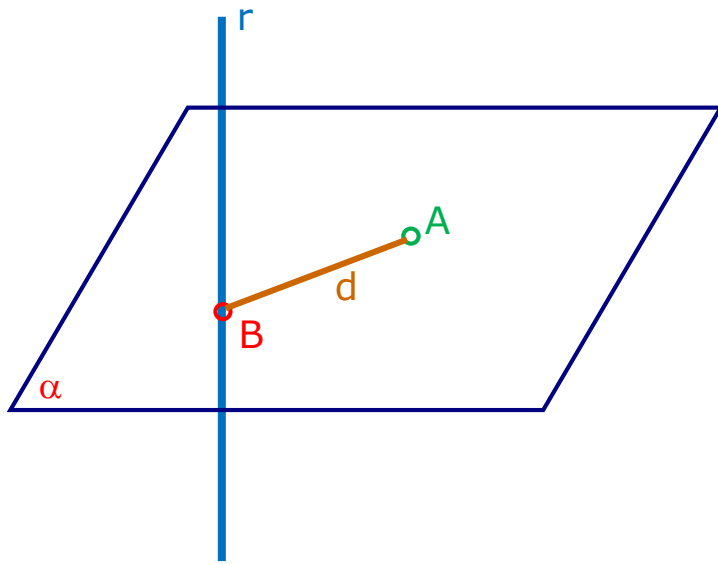

1. Plane $\alpha \perp$ to r and contains A
2. Intersection of line r with plane α

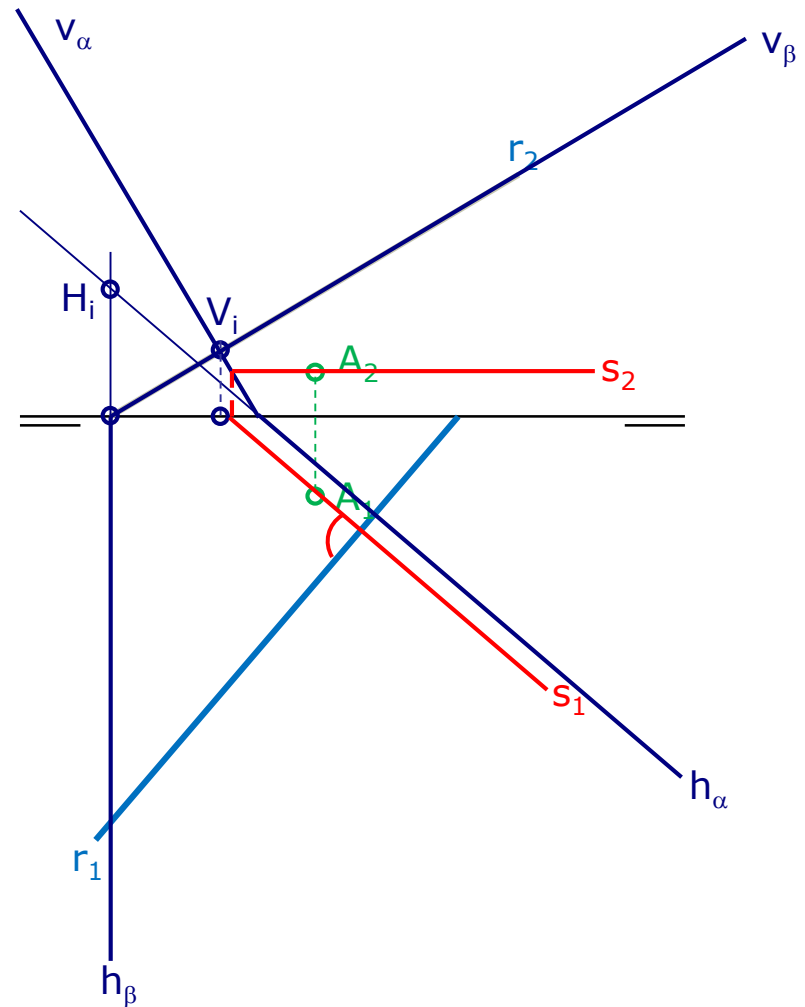

Distance between a point and a line

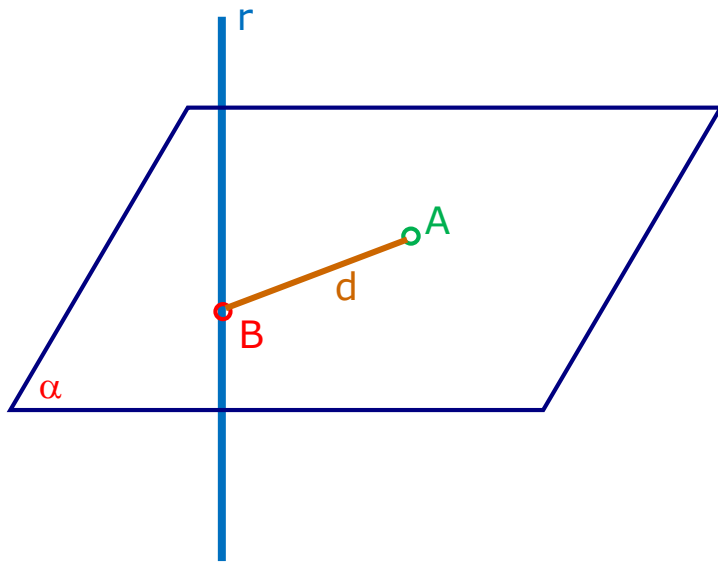

1. Plane $\alpha \perp$ to r and contains A
2. Intersection of line r with plane α

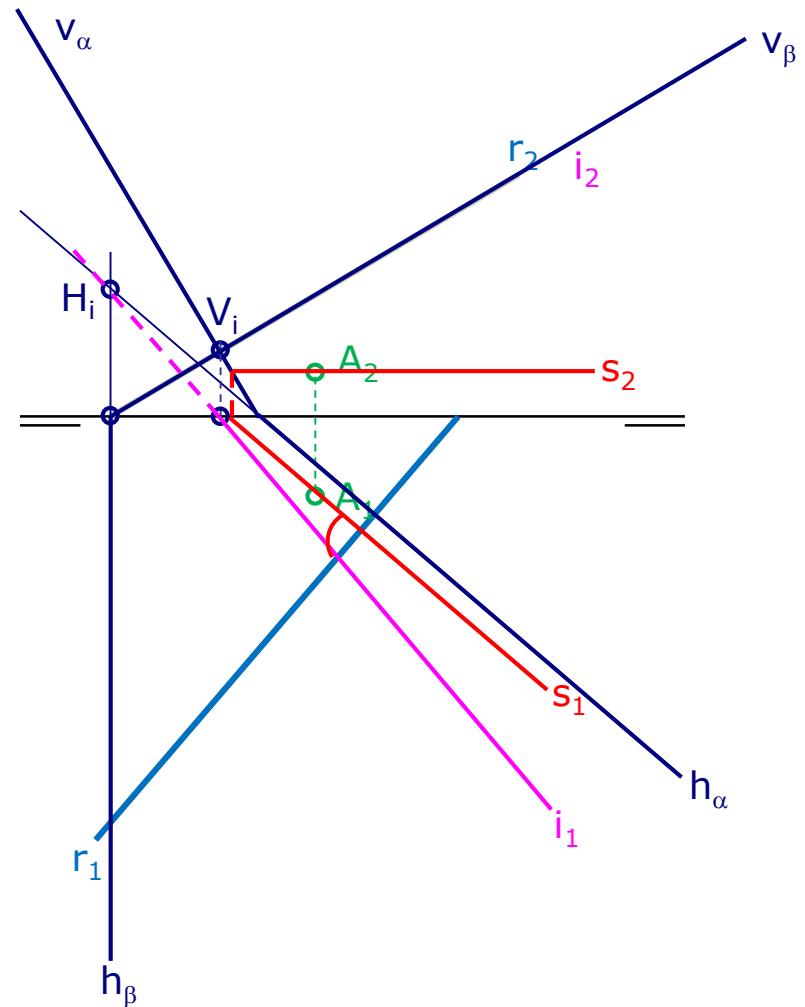

Distance between a point and a line

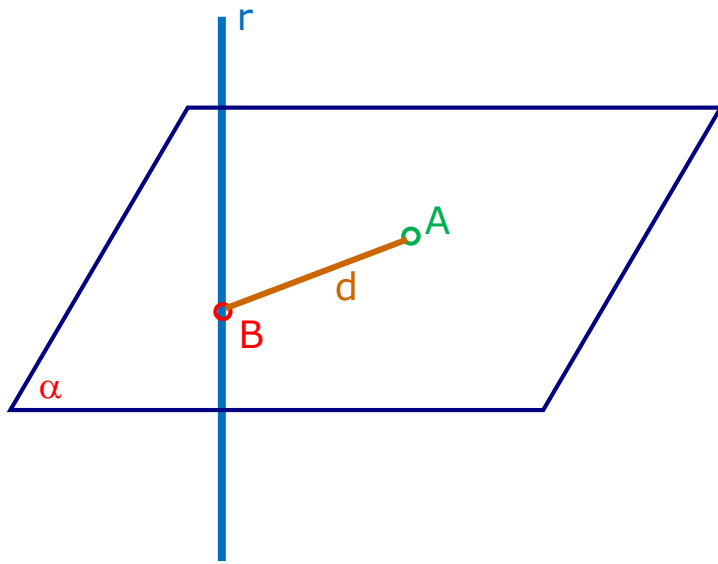

1. Plane $\alpha \perp$ to r and contains A
2. Intersection of line r with plane α

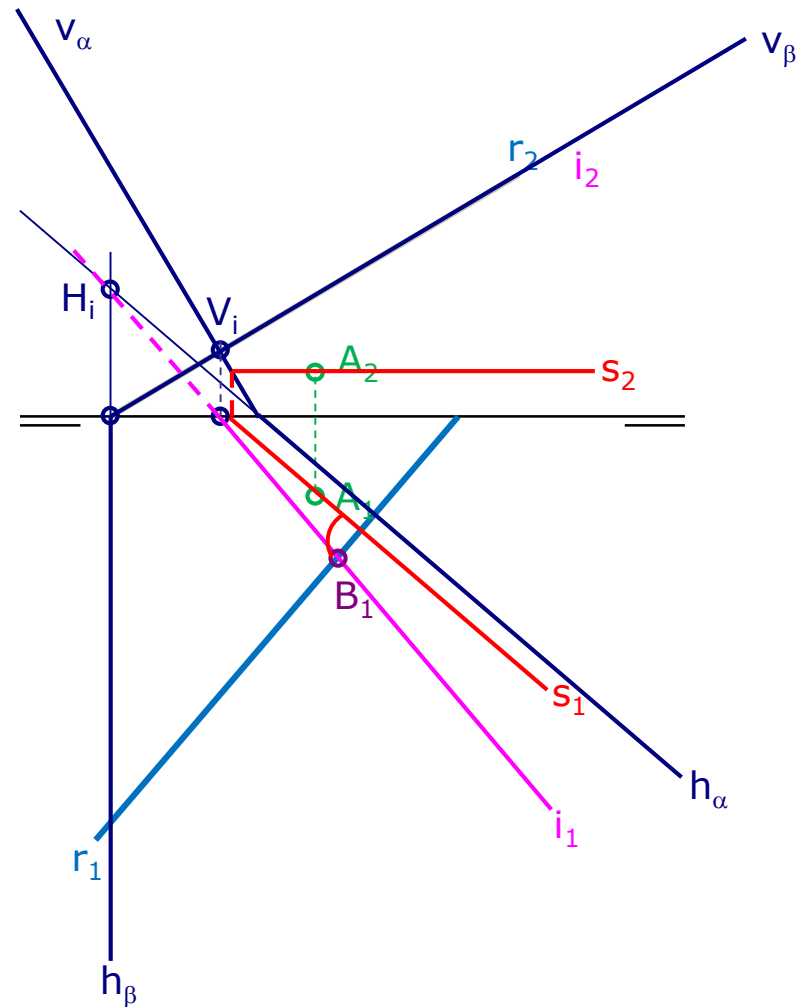

Distance between a point and a line

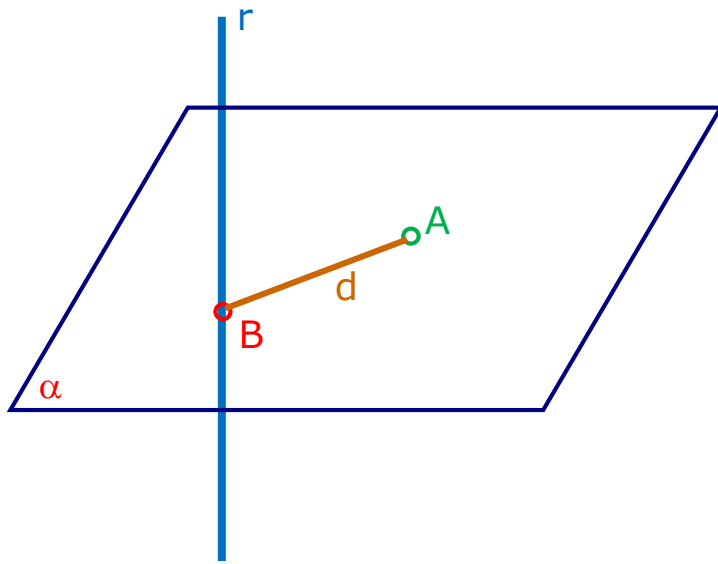

1. Plane $\alpha \perp$ to r and contains A
2. Intersection of line r with plane α

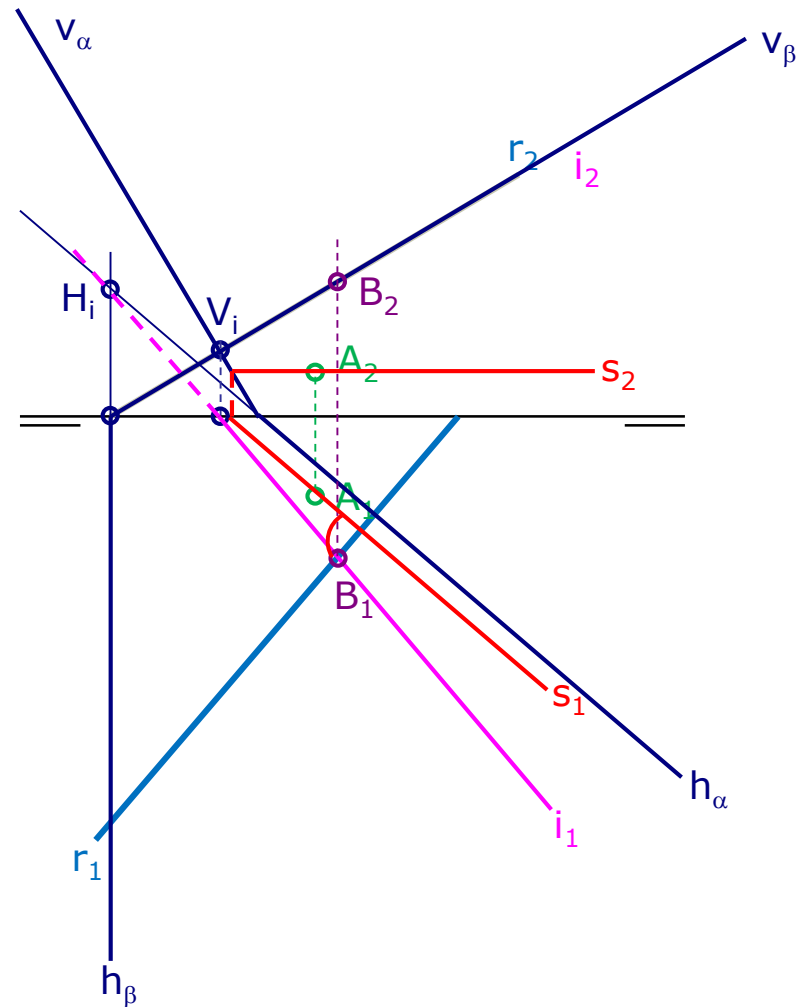

Distance between a point and a line

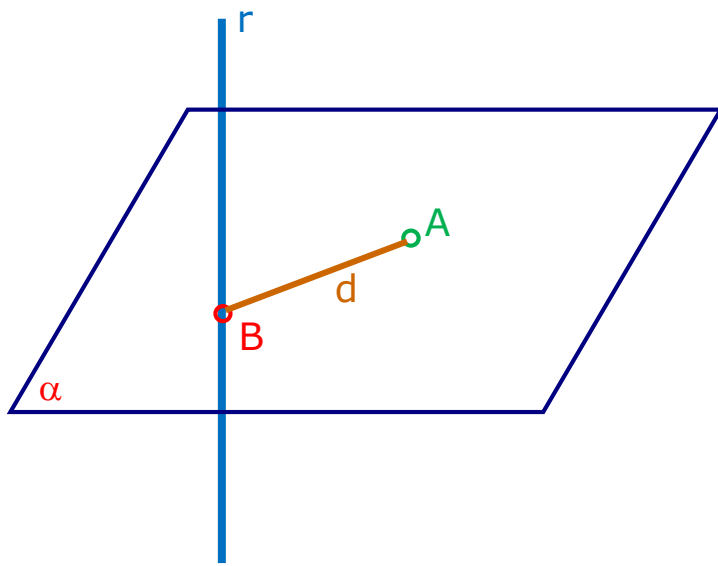

1. Plane $\alpha \perp$ to r and contains A
2. Intersection of line r with plane α

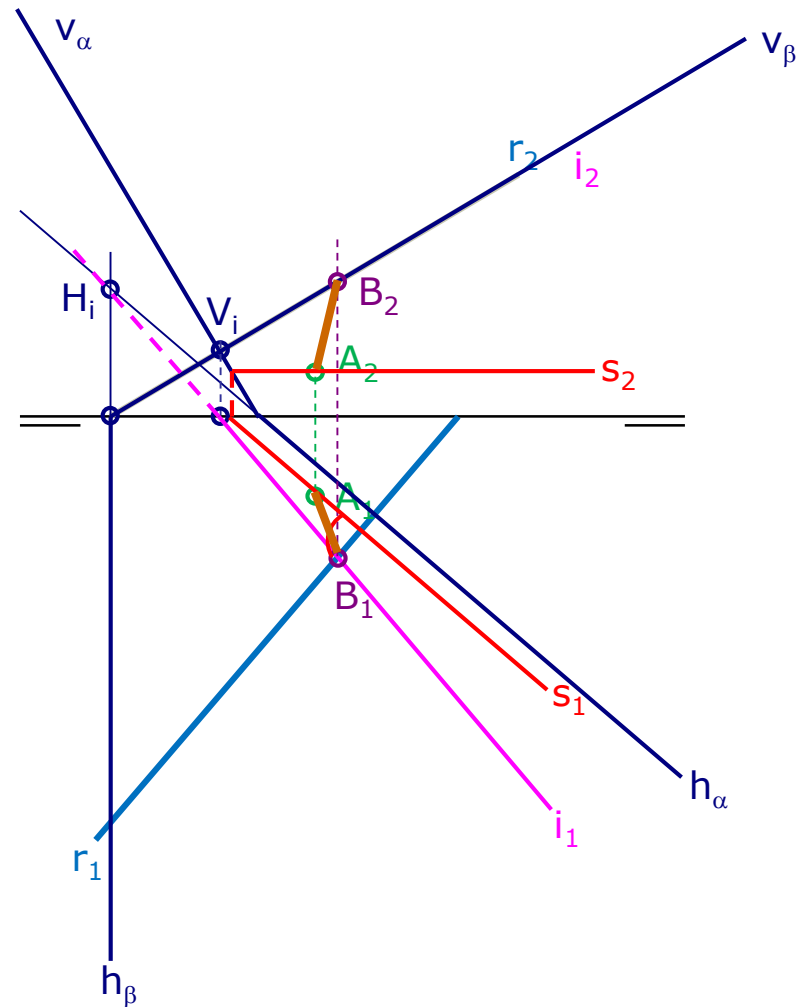

Distance between two parallel planes

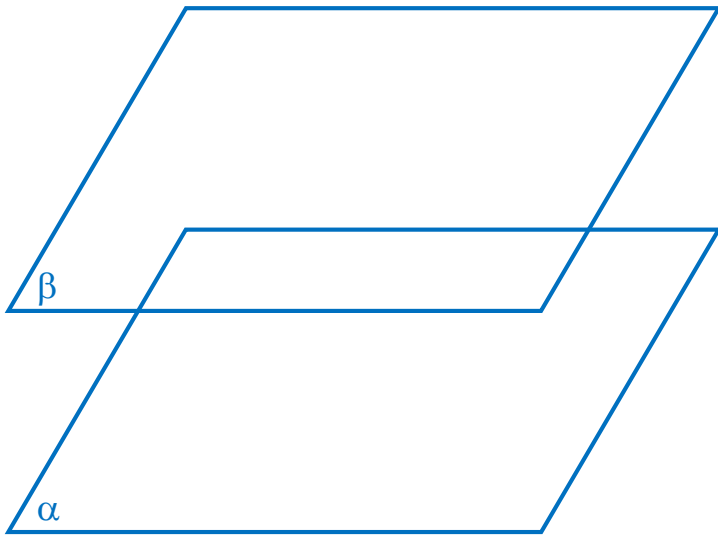

Distance between two parallel planes

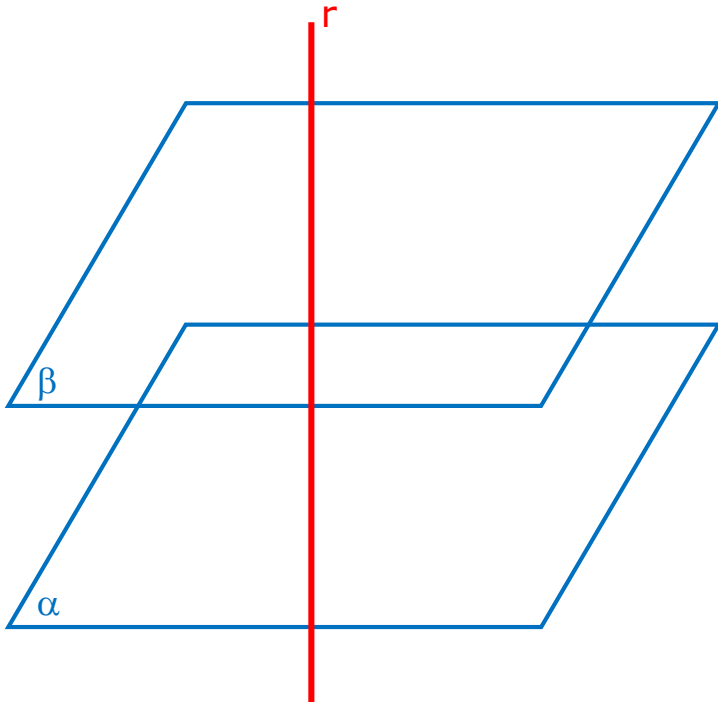

1. line $r \perp$ to planes α and β

Distance between two parallel planes

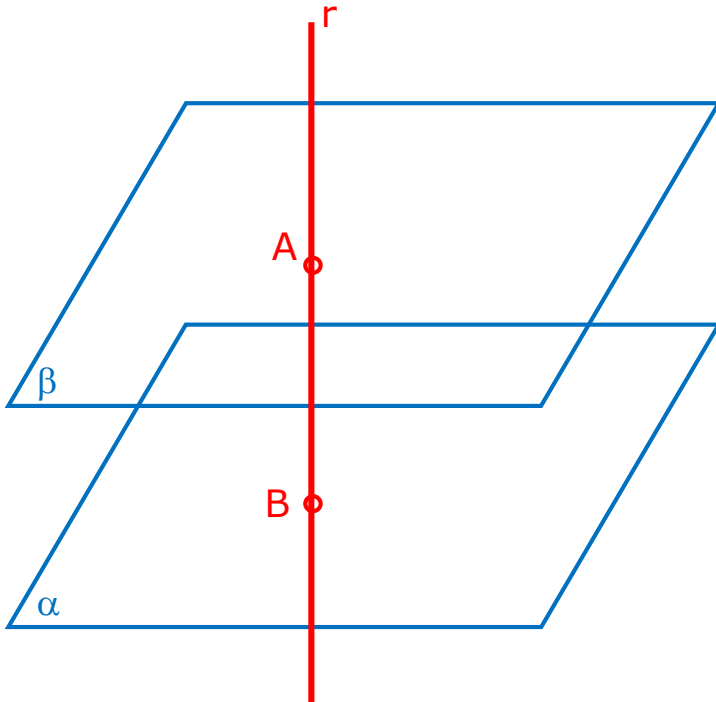

1. line $r \perp$ to planes α and β
2. Intersection between line r and planes α and β

Distance between two parallel planes

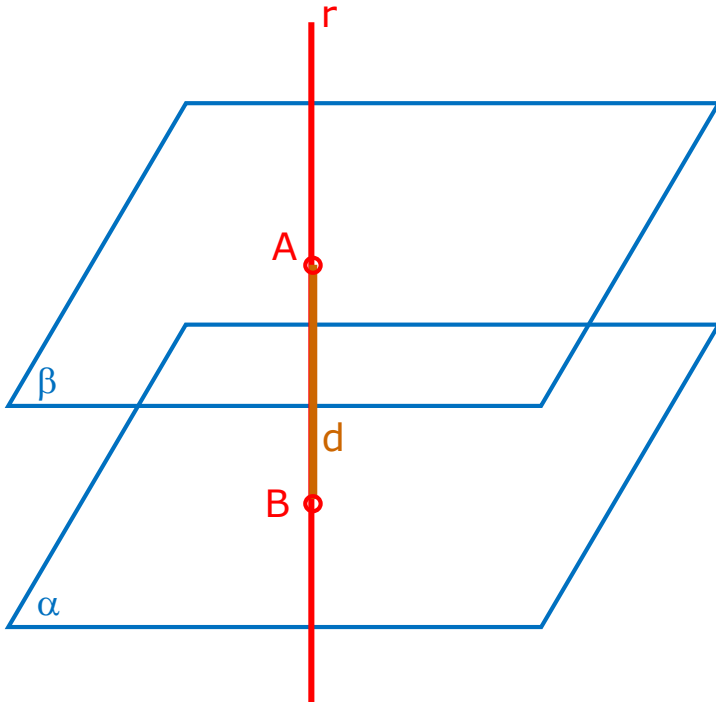

1. line $r \perp$ to planes α and β
2. Intersection between line r and planes α and β

Distance between two parallel planes

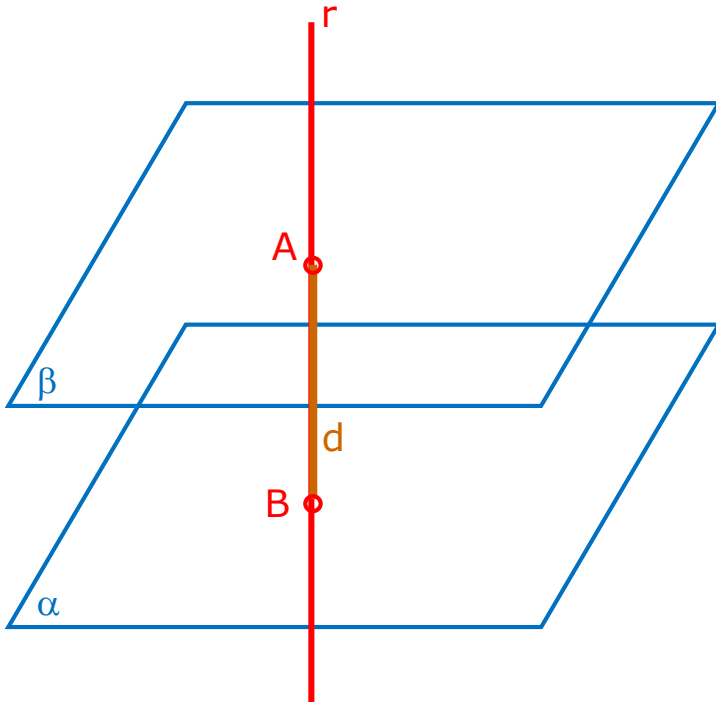

1. line $r \perp$ to planes α and β
2. Intersection between line r and planes α and β

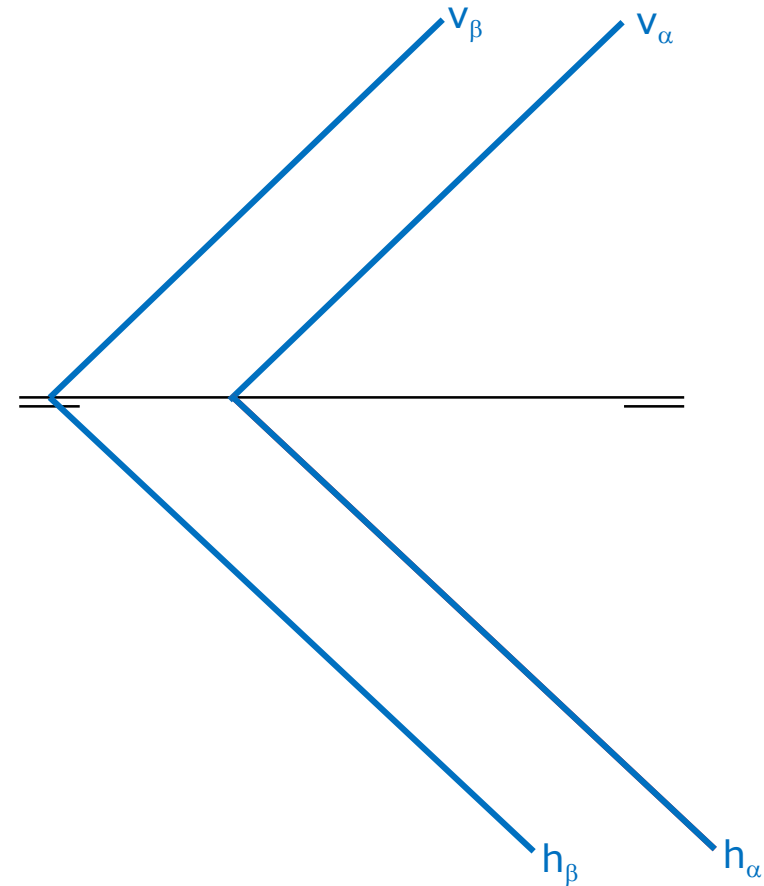

Distance between two parallel planes

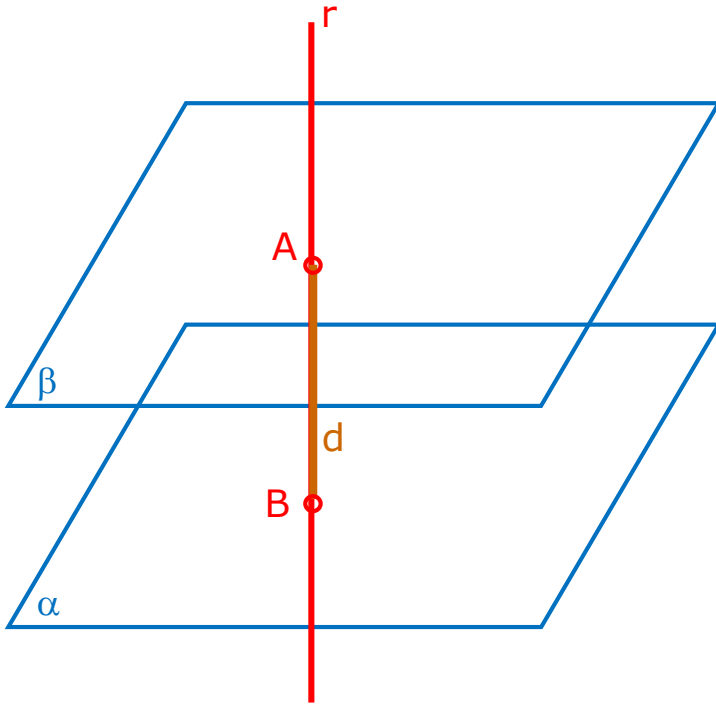

1. line $r \perp$ to planes α and β
2. Intersection between line r and planes α and β

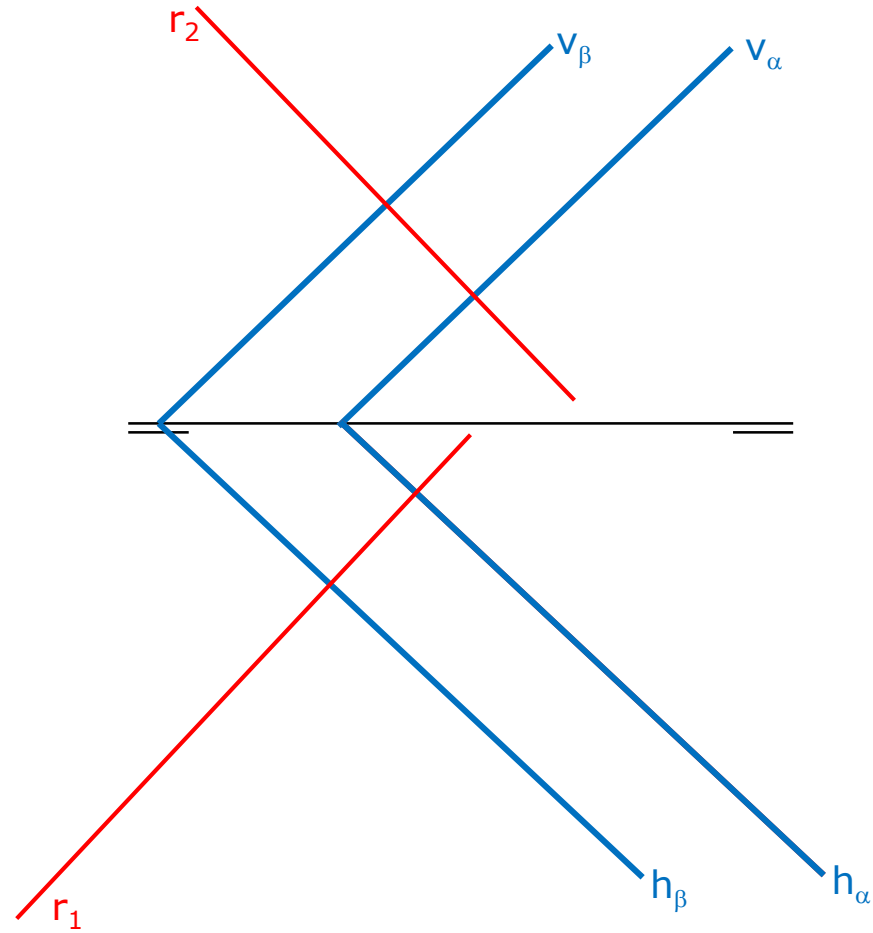

Distance between two parallel planes

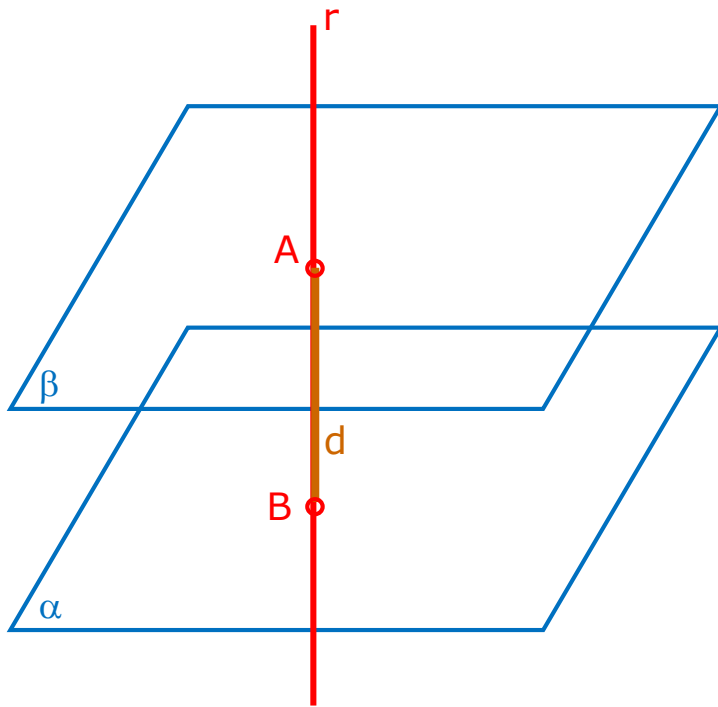

1. line $r \perp$ to planes α and β
2. Intersection between line r and planes α and β

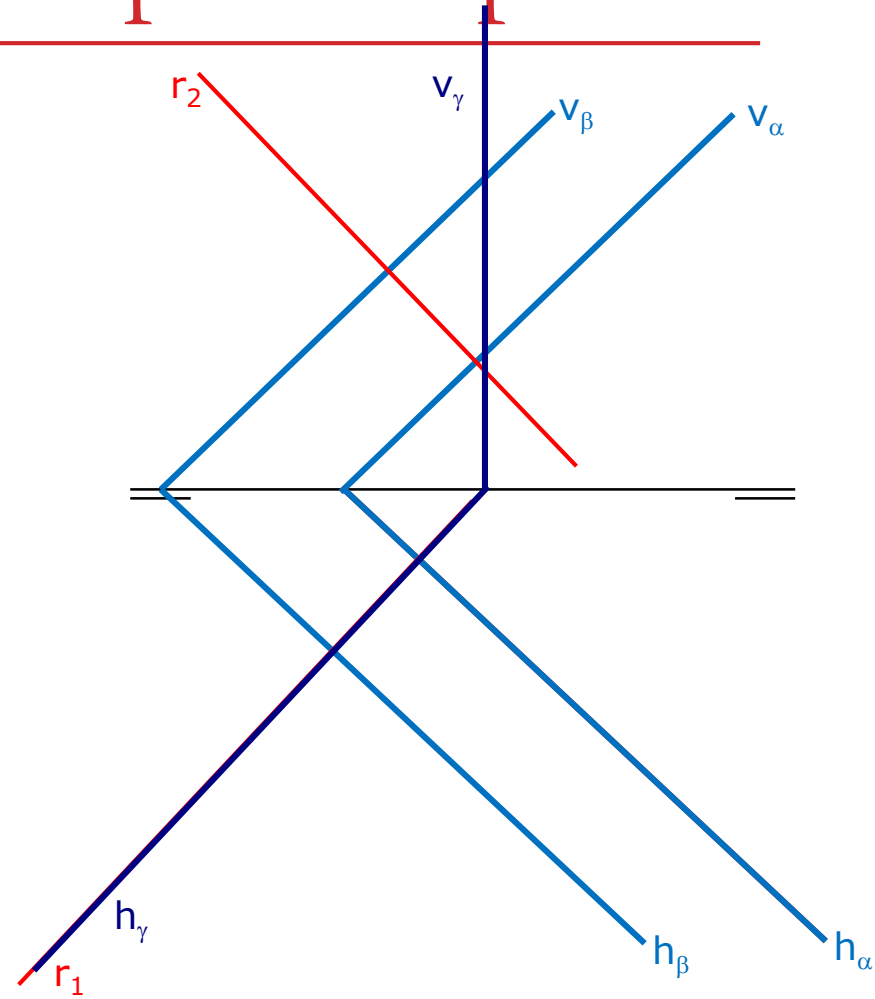

Distance between two parallel planes

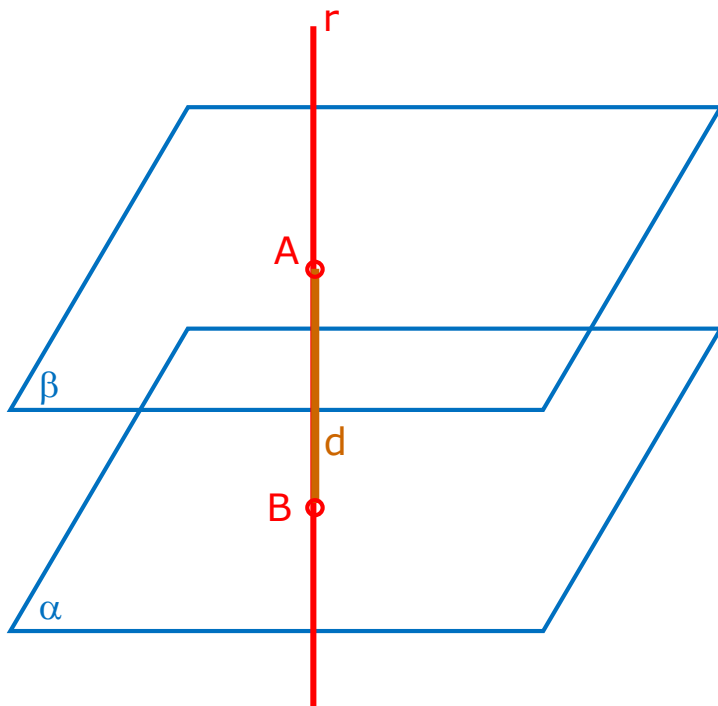

1. line $r \perp$ to planes α and β
2. Intersection between line r and planes α and β

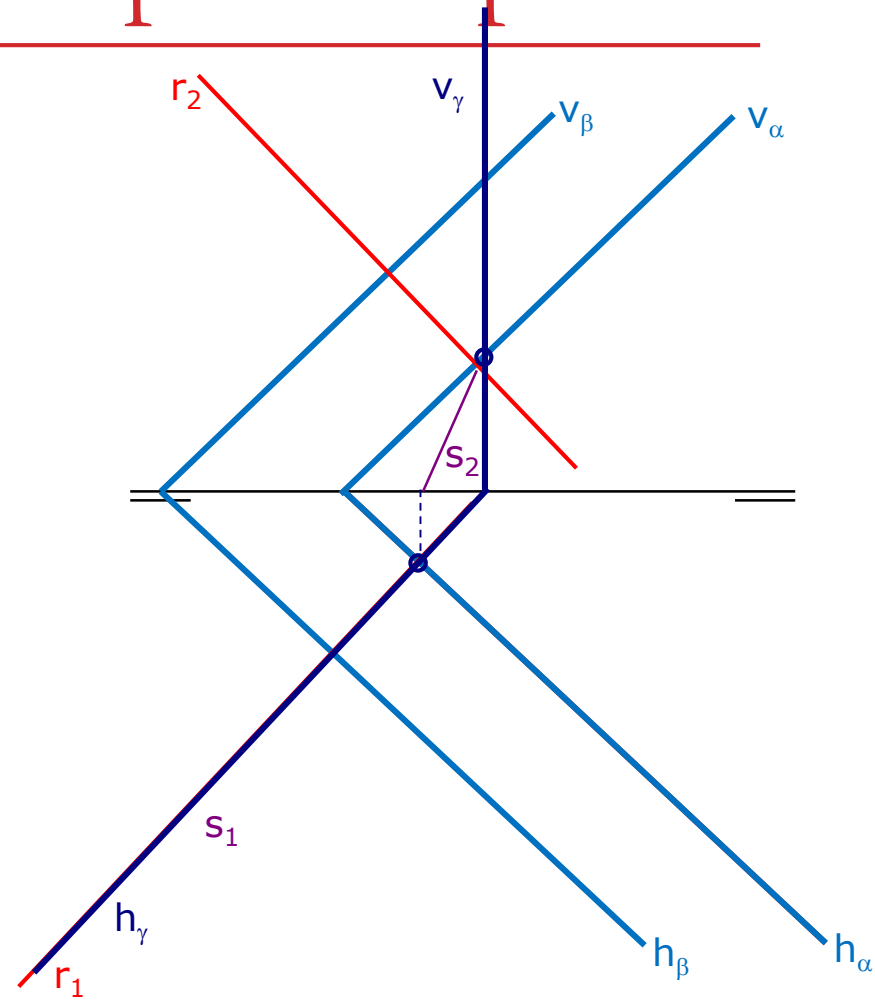

Distance between two parallel planes

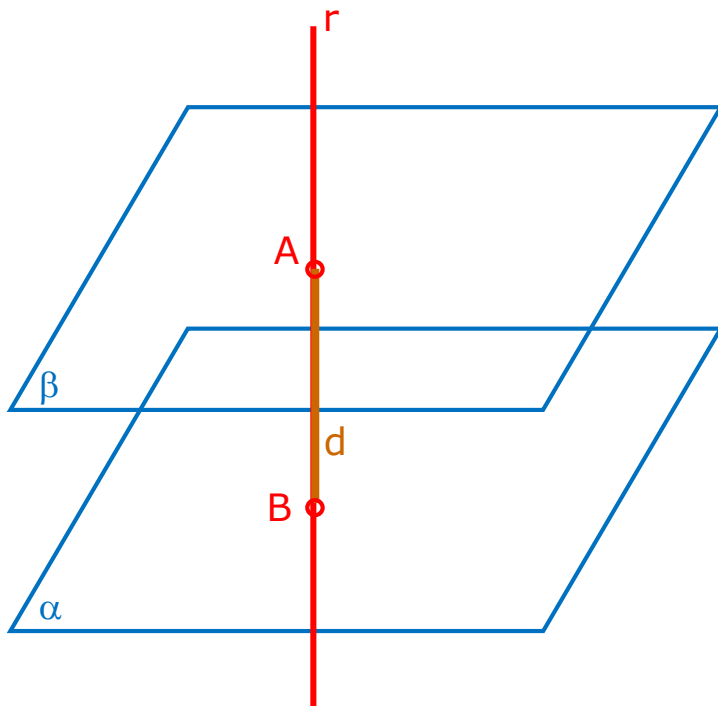

1. line $r \perp$ to planes α and β
2. Intersection between line r and planes α and β

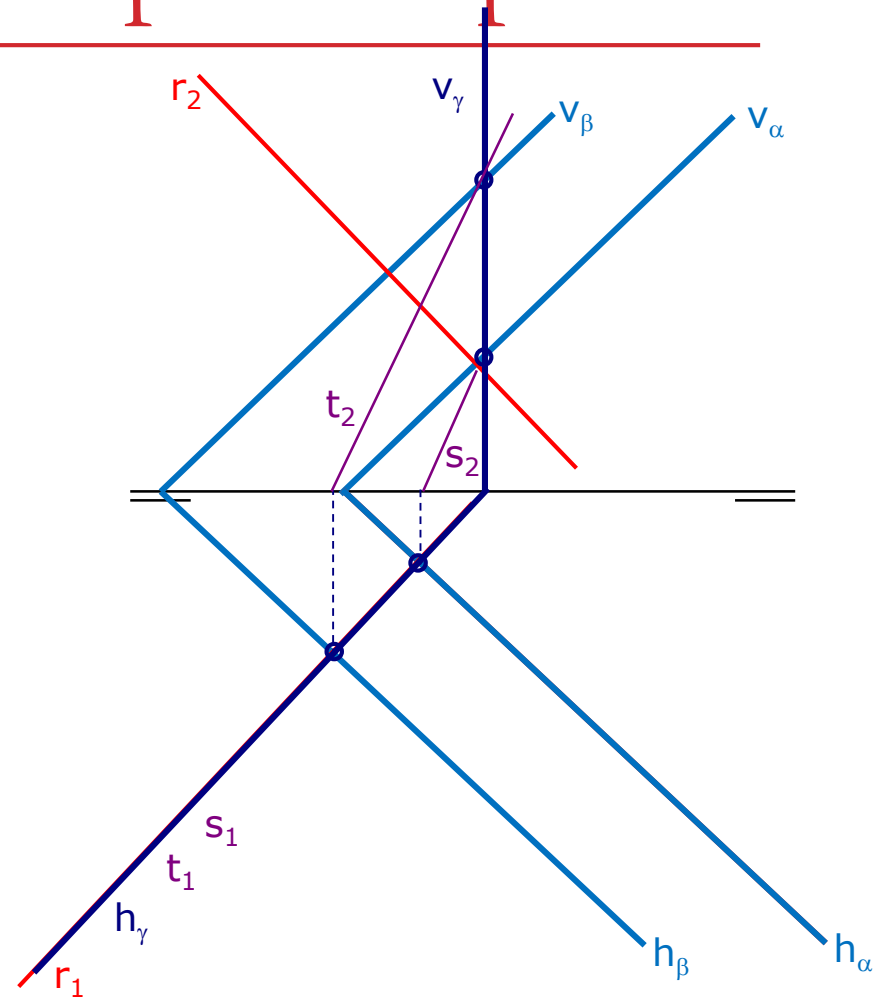

Distance between two parallel planes

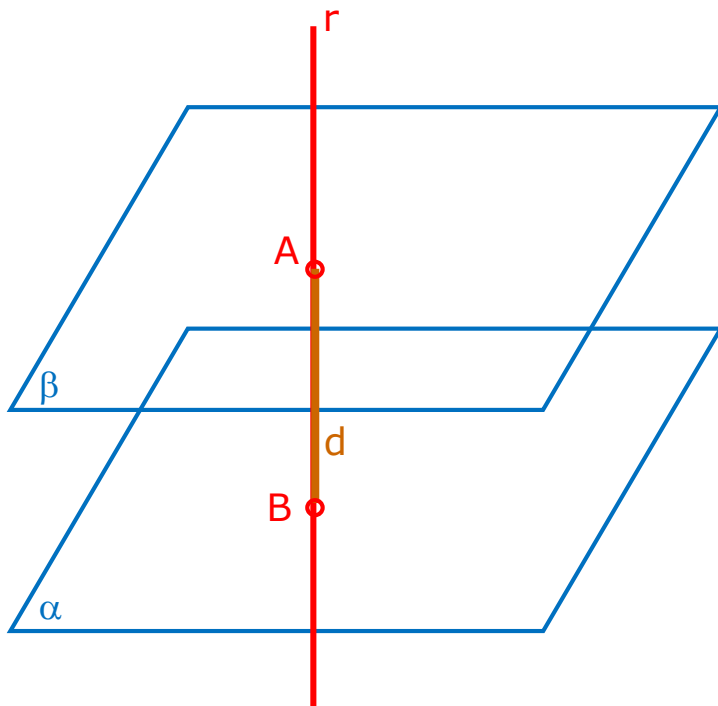

1. line $r \perp$ to planes α and β
2. Intersection between line r and planes α and β

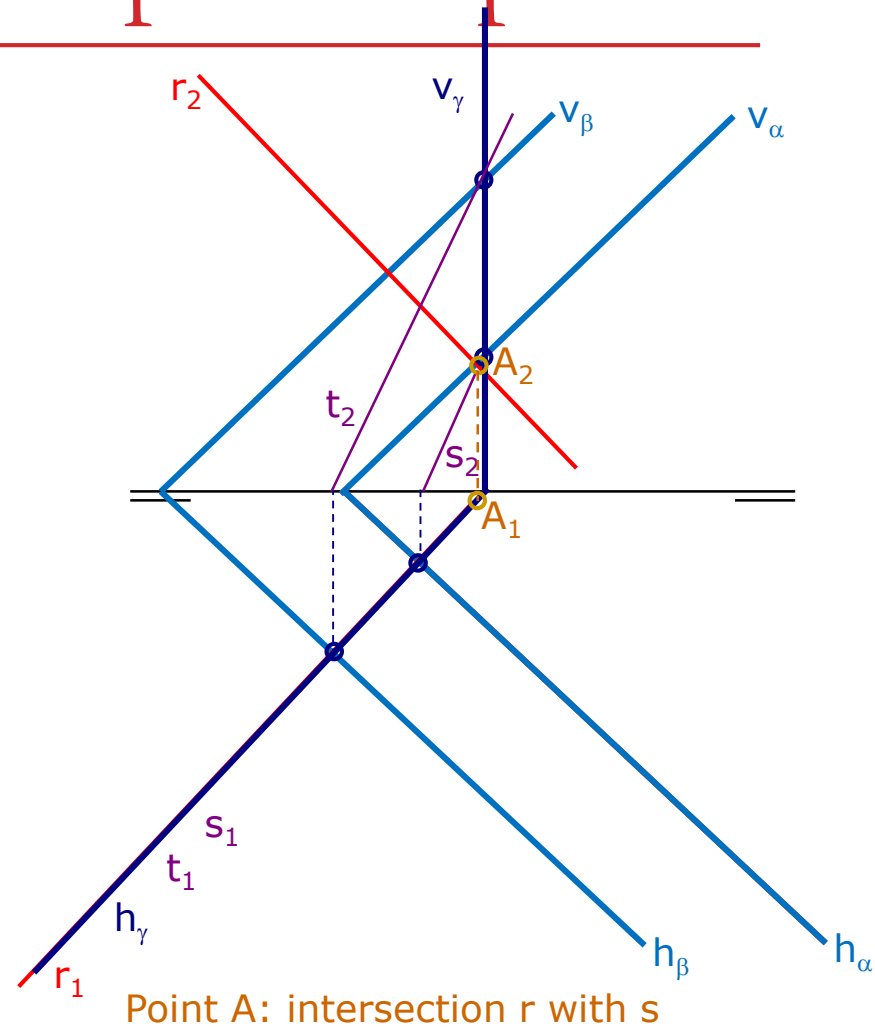

Point A: intersection r with s

Distance between two parallel planes

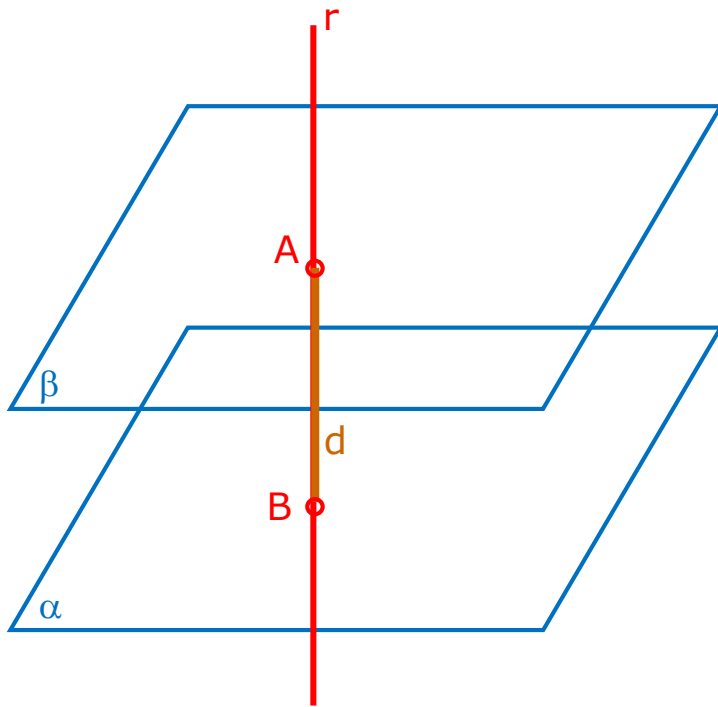

1. line $r \perp$ to planes α and β
2. Intersection between line r and planes α and β

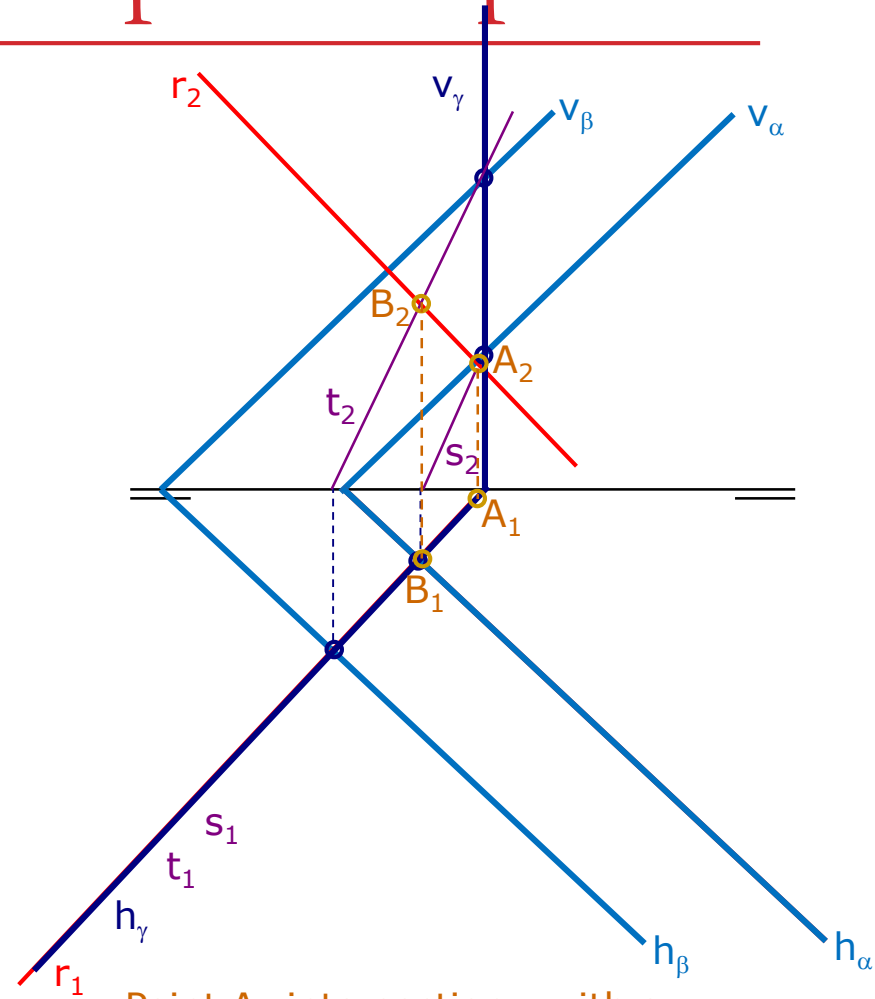

Point A: intersection r with s
 Point B: intersection r with t

Distance between two parallel planes

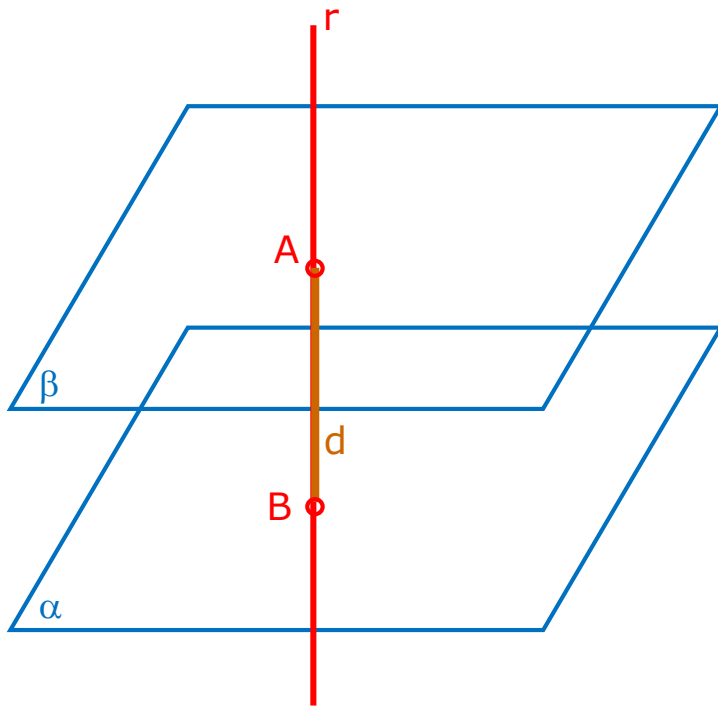

1. line $r \perp$ to planes α and β
2. Intersection between line r and planes α and β

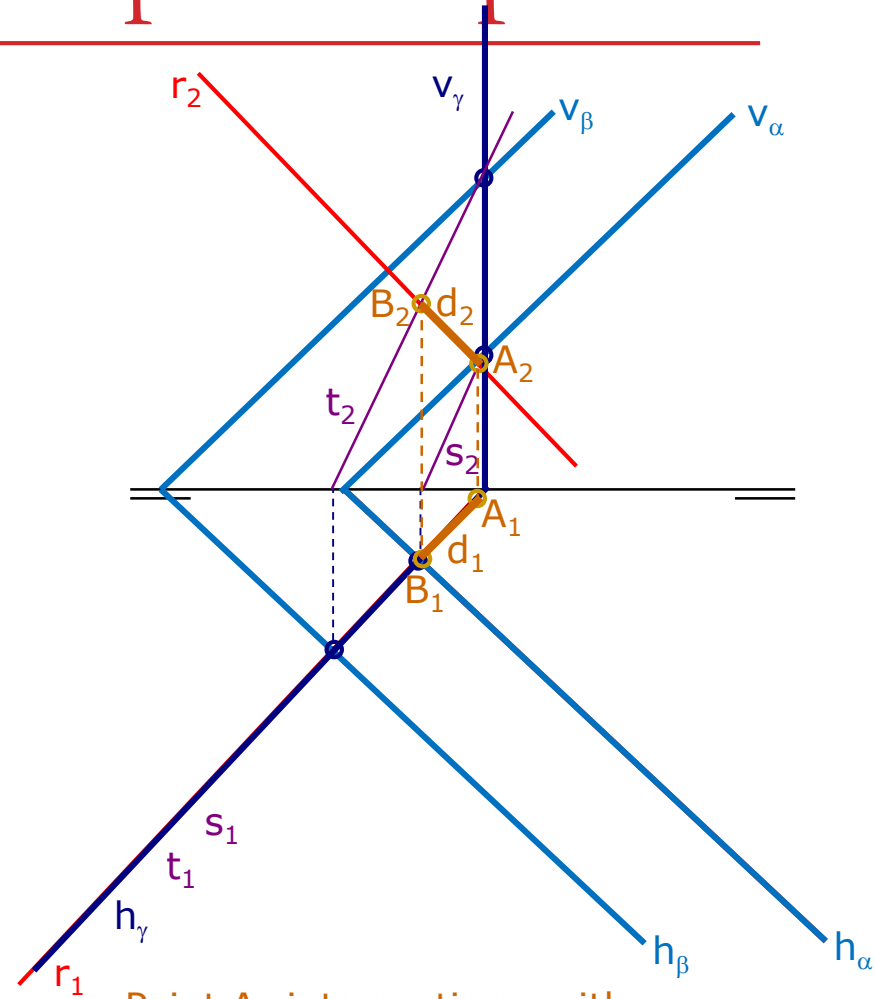

Point A: intersection r with s
 Point B: intersection r with t

Distance between two parallel lines

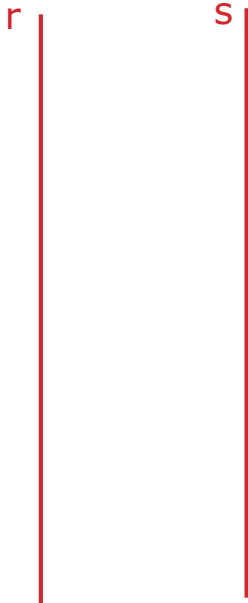

Distance between two parallel lines

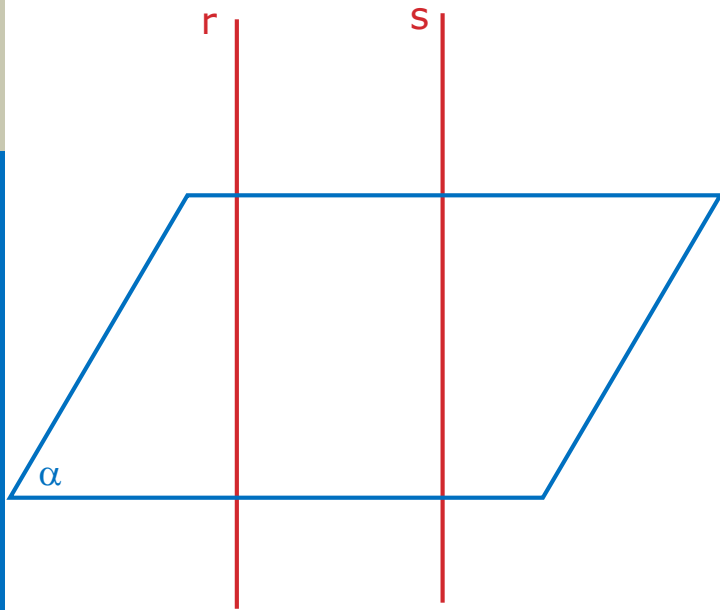

1. Plane $\alpha \perp$ to lines r and s

Distance between two parallel lines

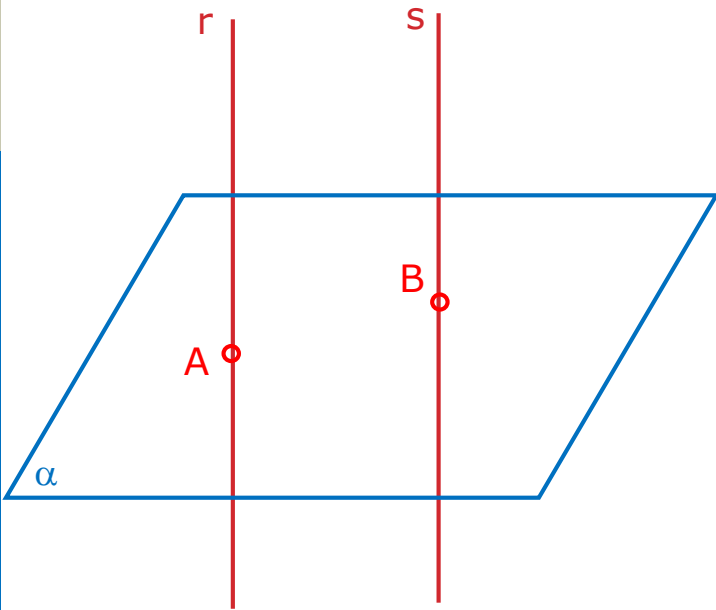

1. Plane $\alpha \perp$ to lines r and s
2. Intersection between plane α and lines r and s

Distance between two parallel lines

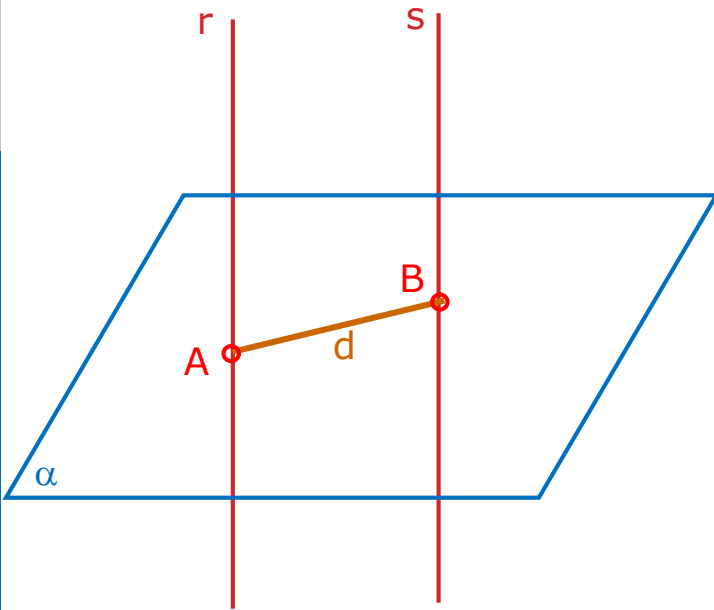

1. Plane $\alpha \perp$ to lines r and s
2. Intersection between plane α and lines r and s

Distance between two parallel lines

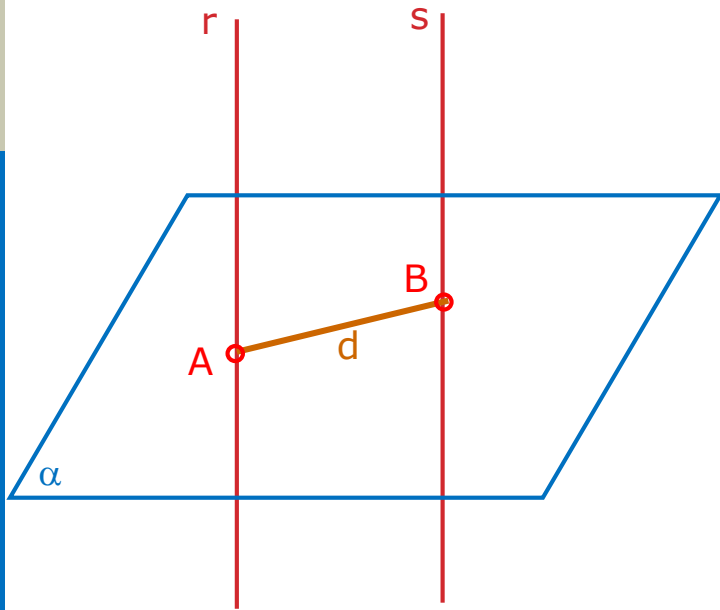

1. Plane $\alpha \perp$ to lines r and s
2. Intersection between plane α and lines r and s

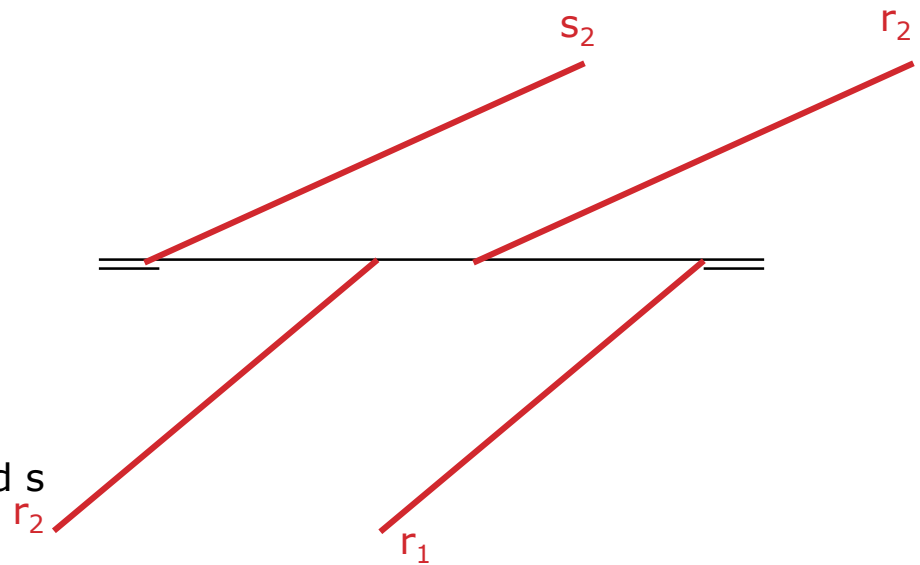

Distance between two parallel lines

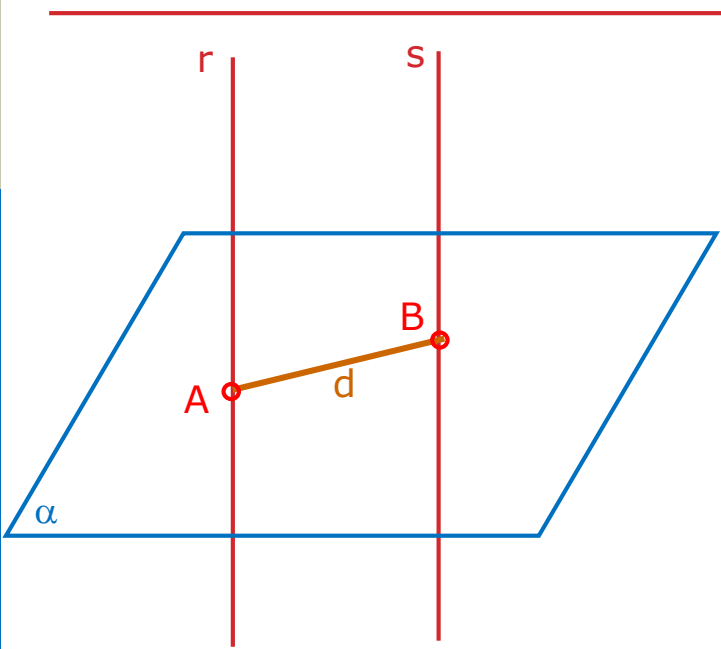

1. Plane $\alpha \perp$ to lines r and s
2. Intersection between plane α and lines r and s

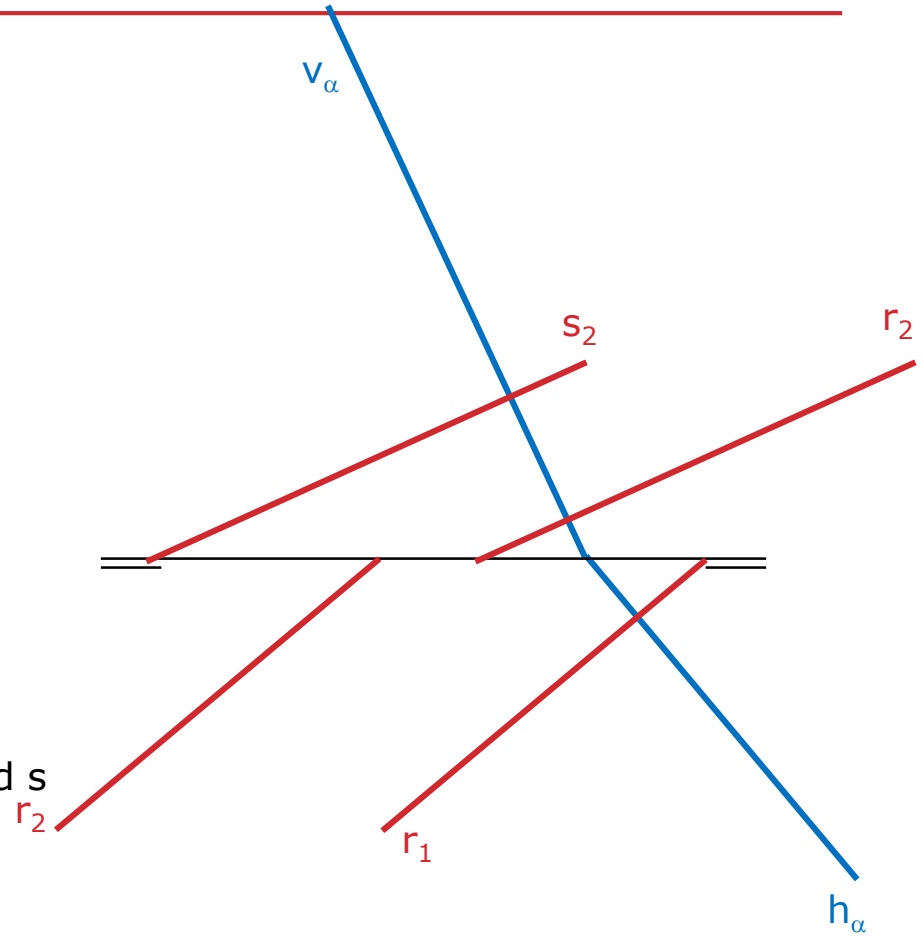

Distance between two parallel lines

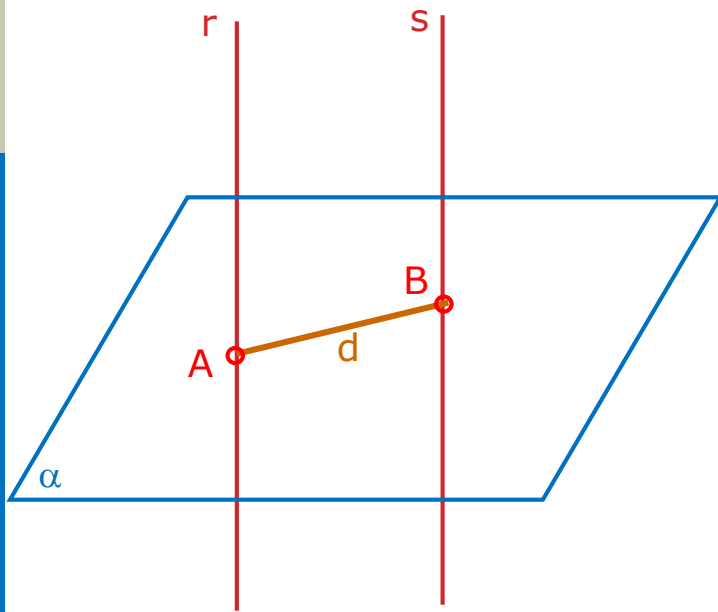

1. Plane $\alpha \perp$ to lines r and s
2. Intersection between plane α and lines r and s

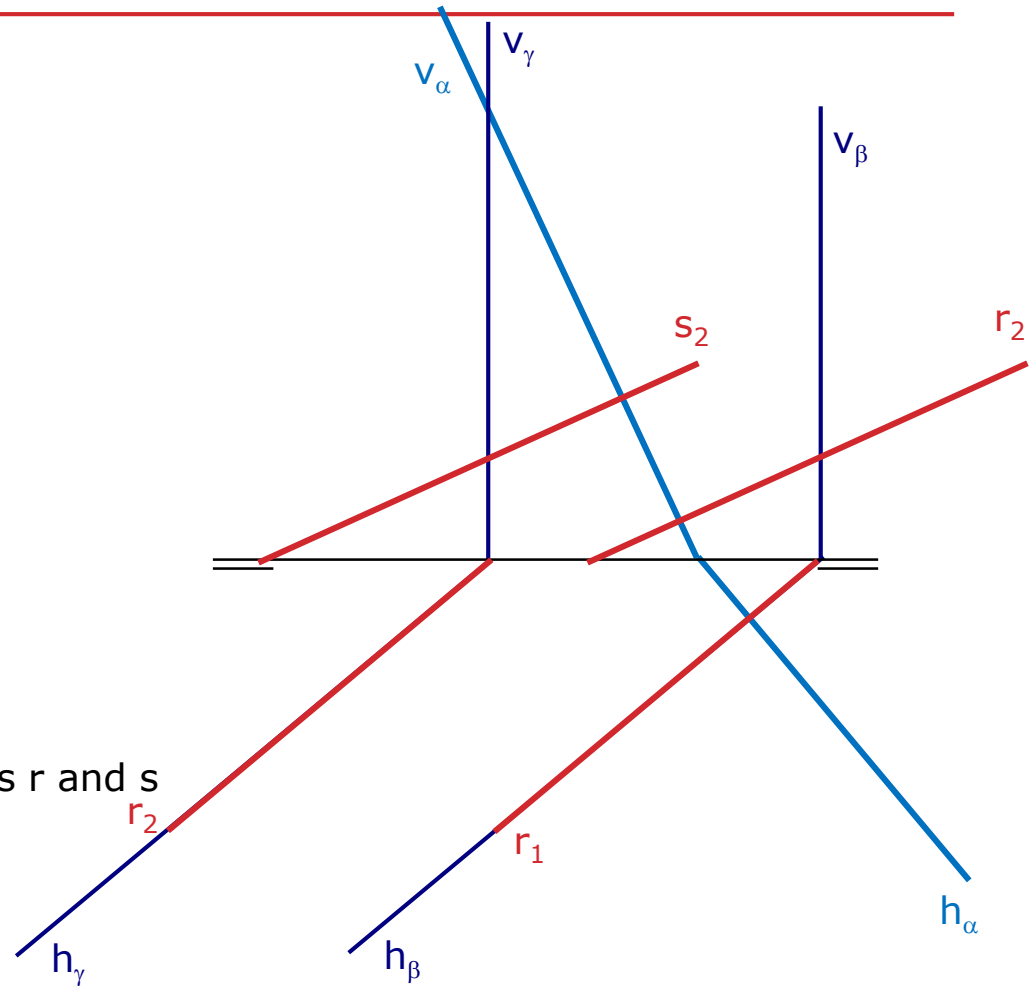

Distance between two parallel lines

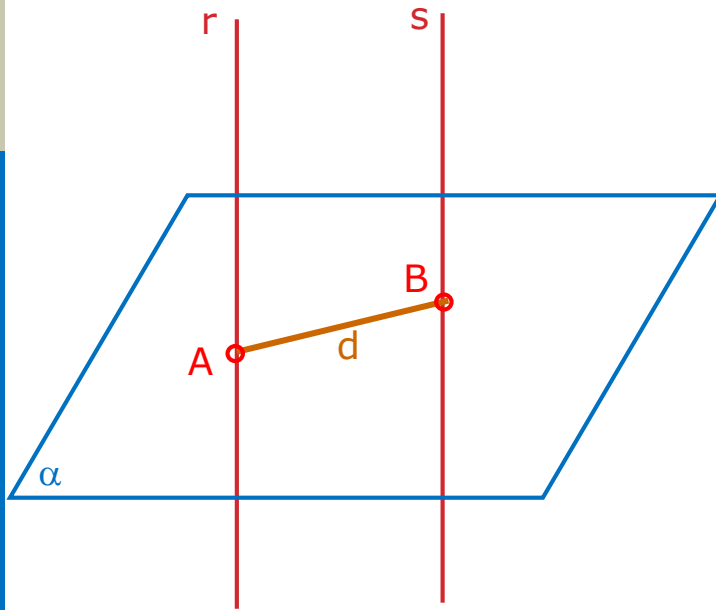

1. Plane $\alpha \perp$ to lines r and s
2. Intersection between plane α and lines r and s

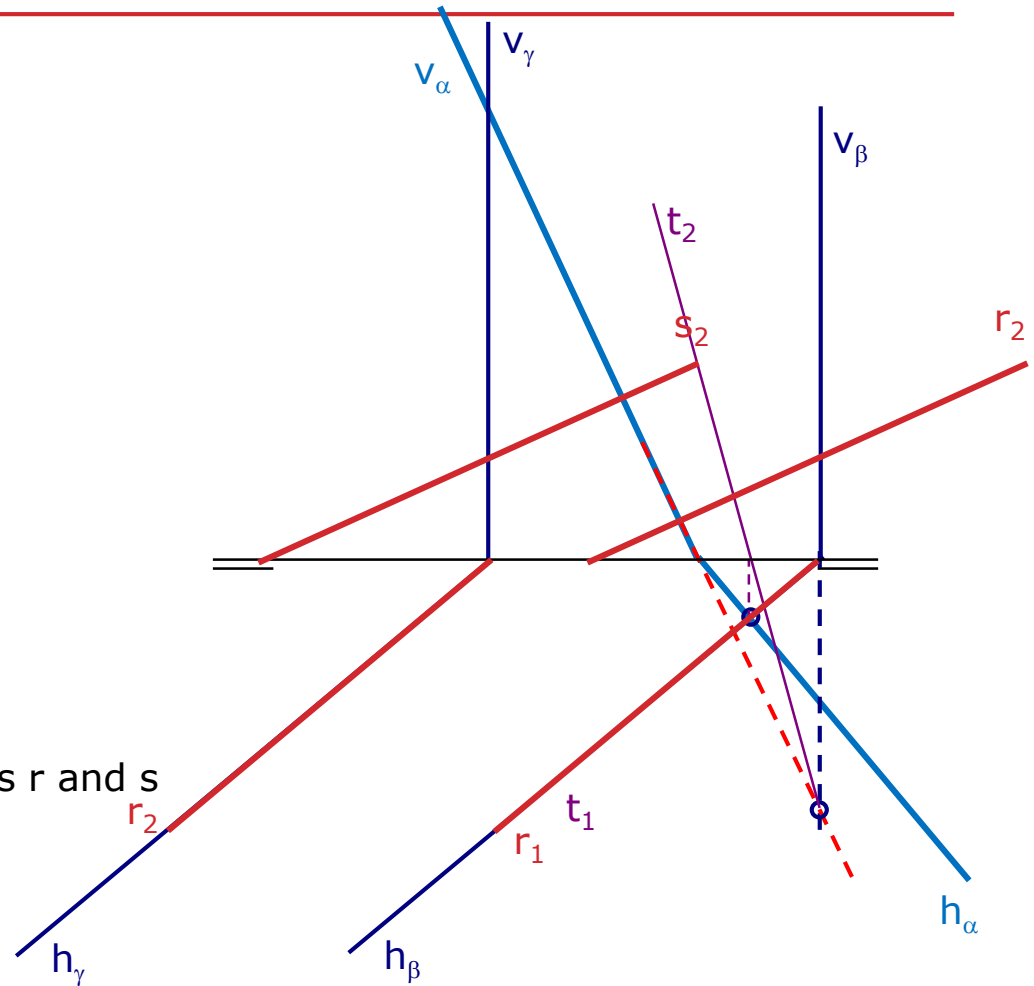

Distance between two parallel lines

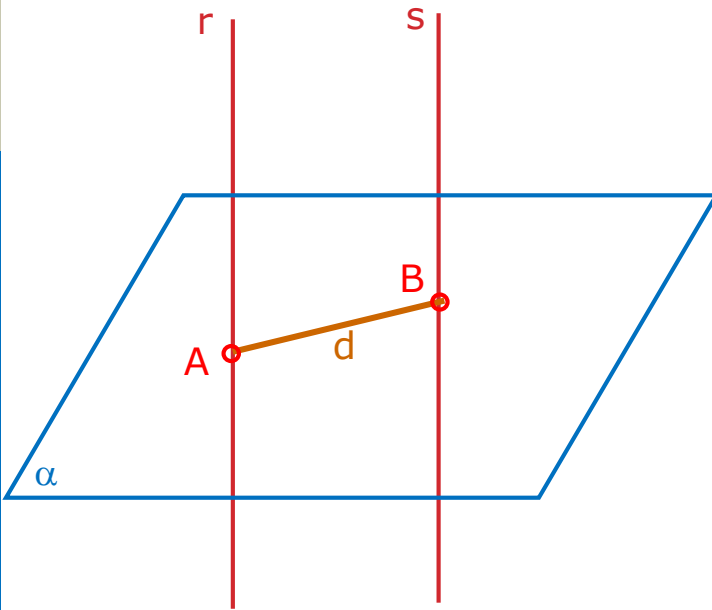

1. Plane $\alpha \perp$ to lines r and s
2. Intersection between plane α and lines r and s

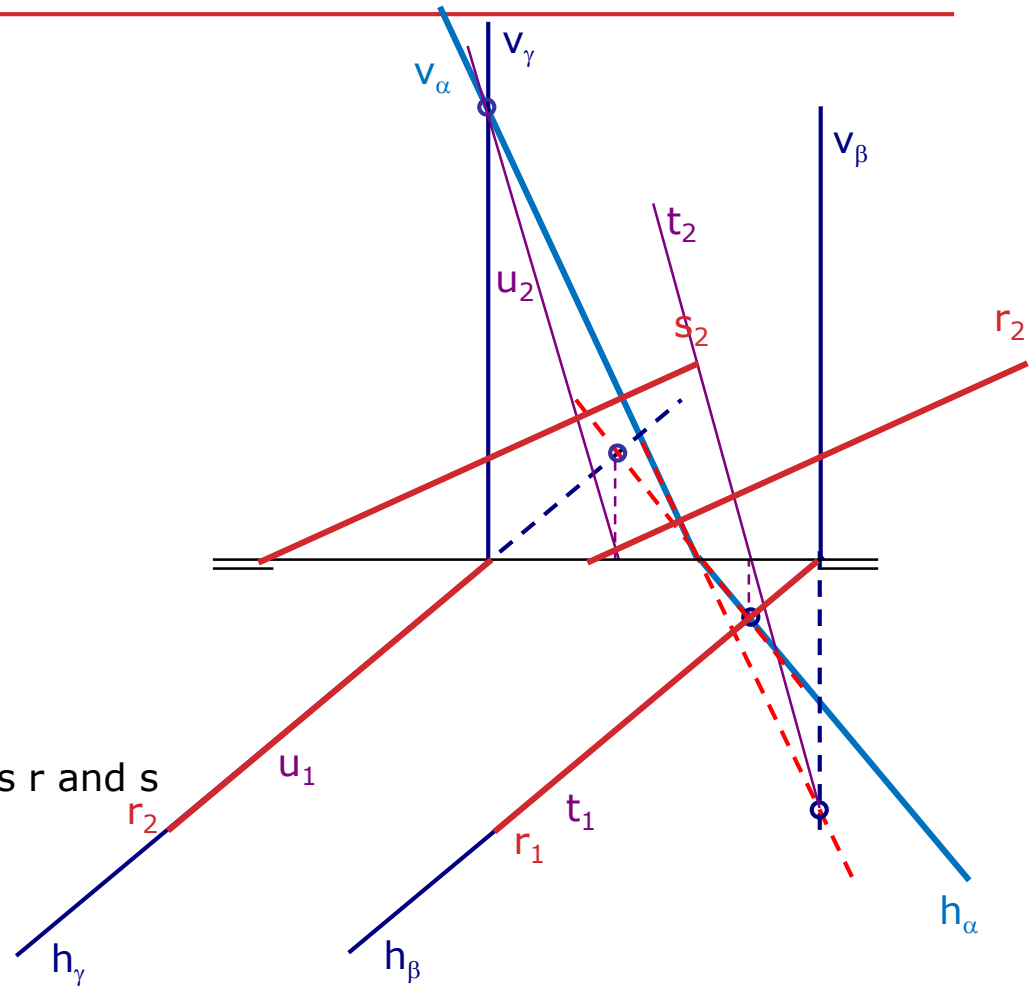

Distance between two parallel lines

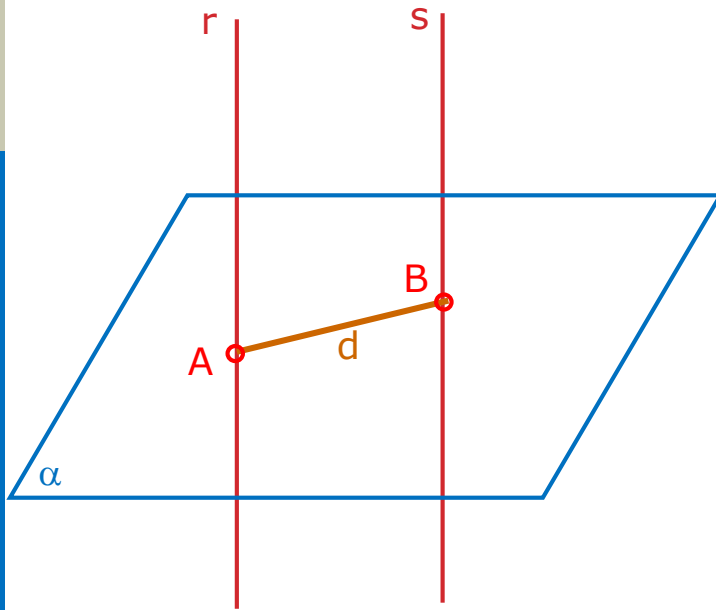

1. Plane $\alpha \perp$ to lines r and s
2. Intersection between plane α and lines r and s

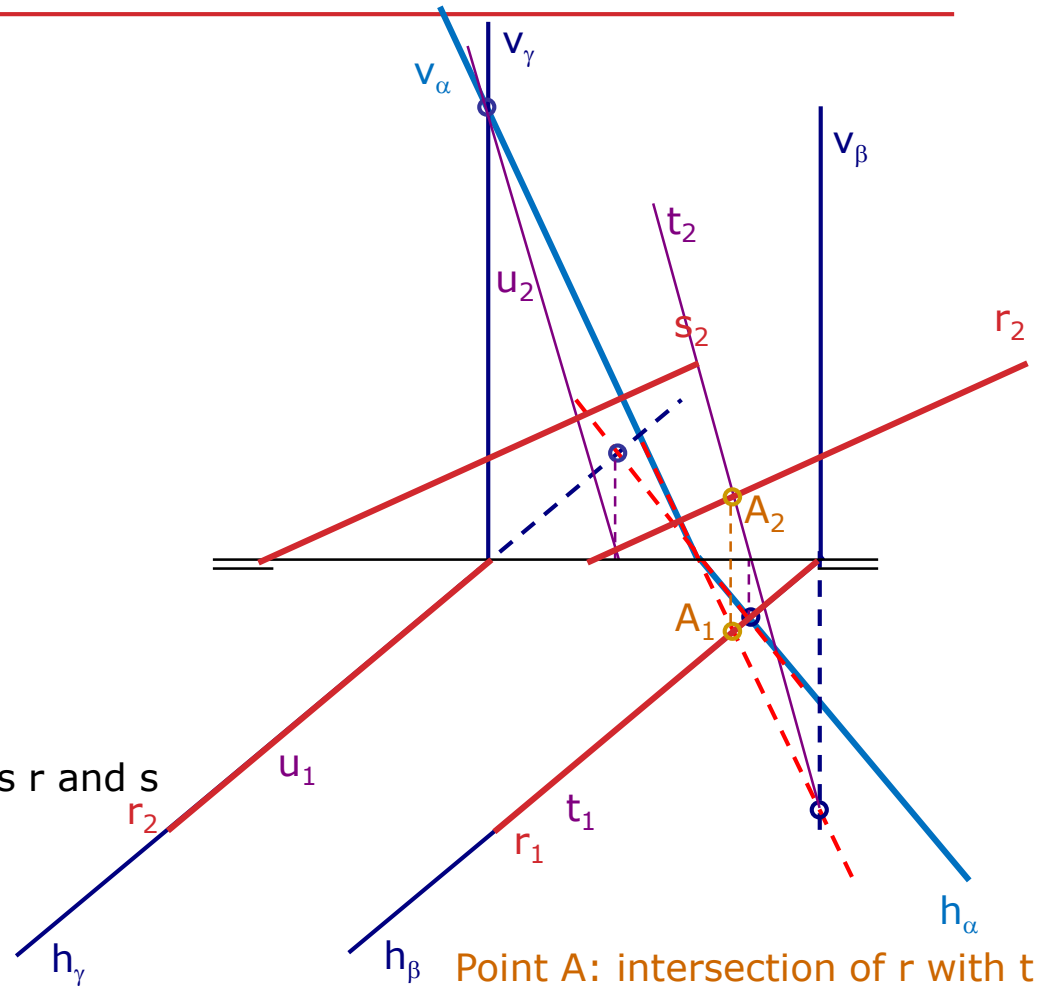

Distance between two parallel lines

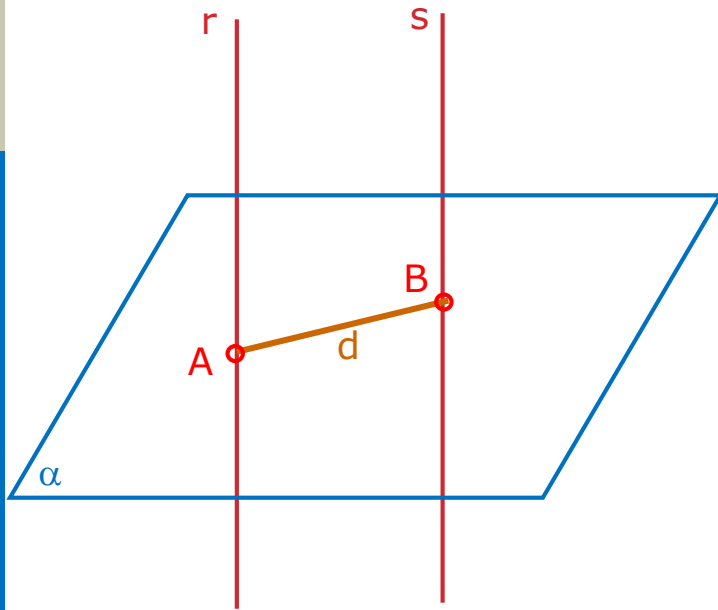

1. Plane $\alpha \perp$ to lines r and s
2. Intersection between plane α and lines r and s

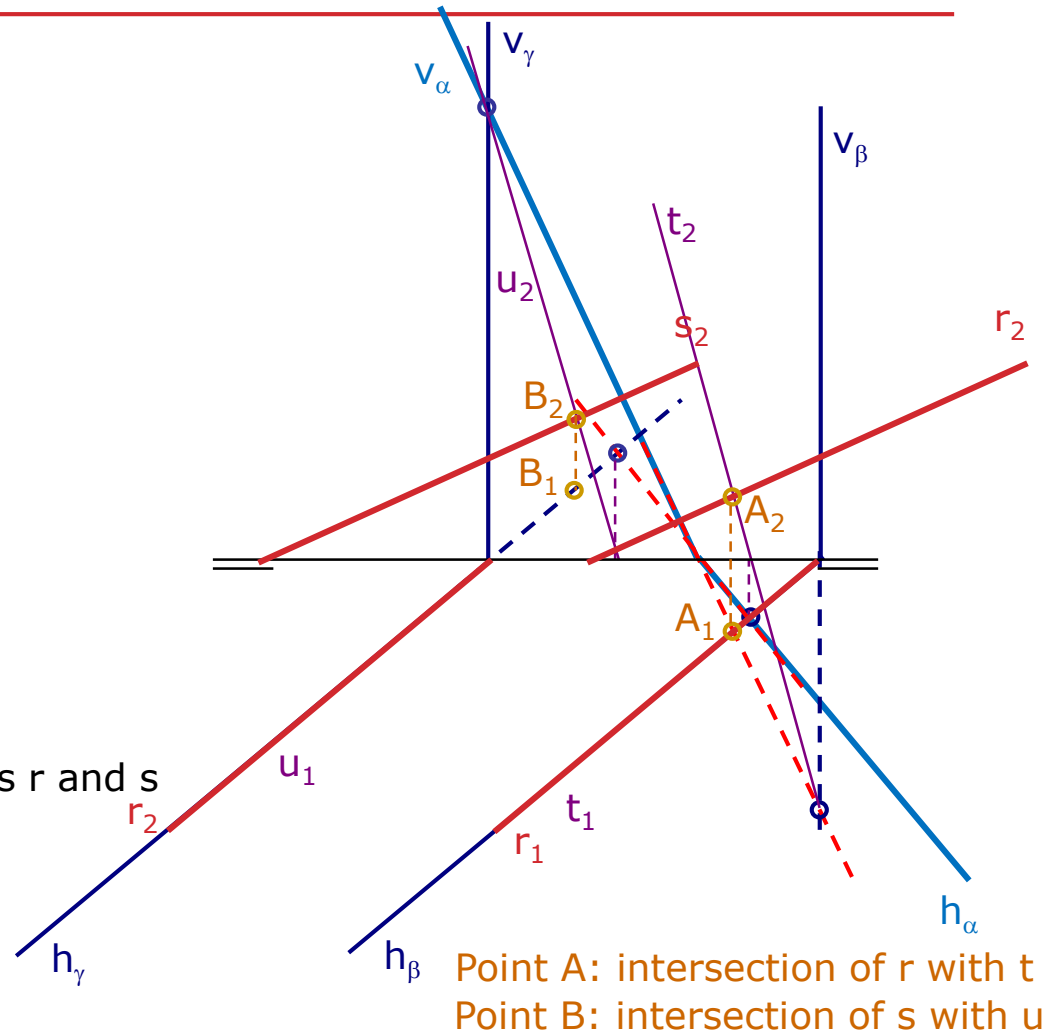

Distance between two parallel lines

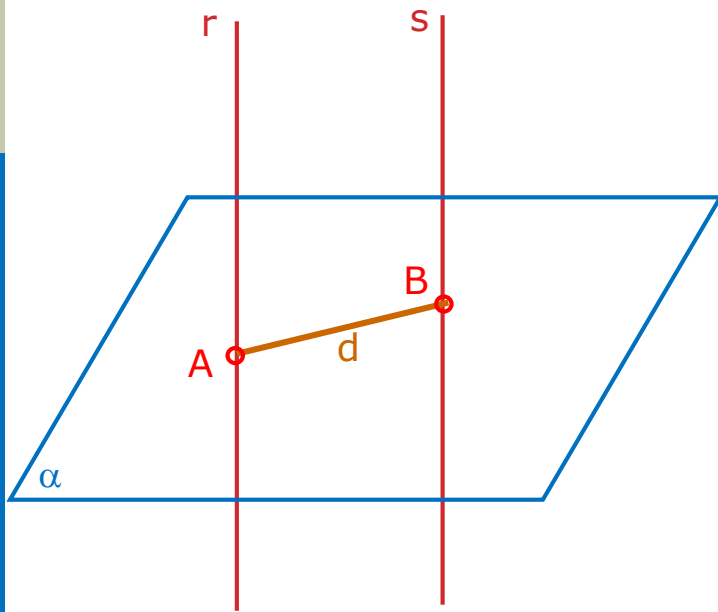

1. Plane $\alpha \perp$ to lines r and s
2. Intersection between plane α and lines r and s

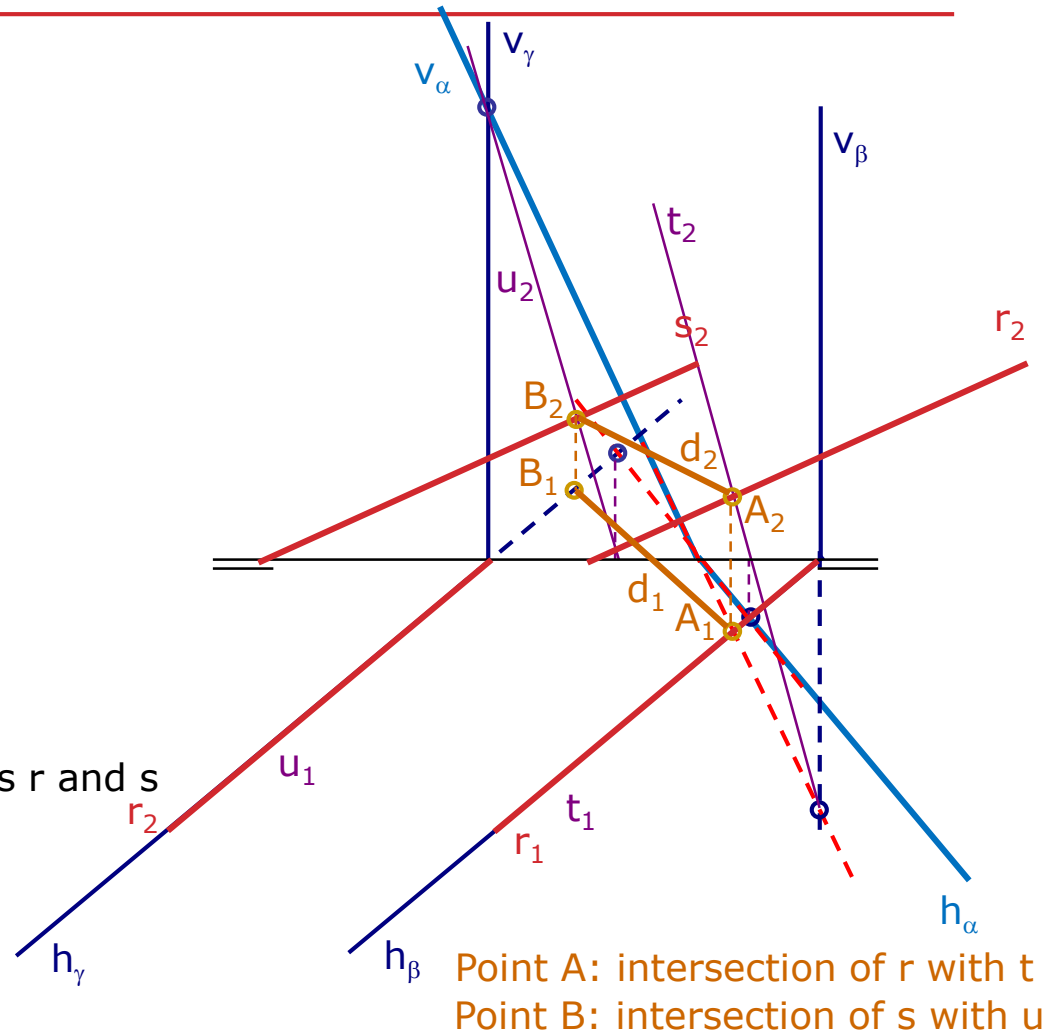

Point A: intersection of r with t
 Point B: intersection of s with u

Distance between two crossing lines

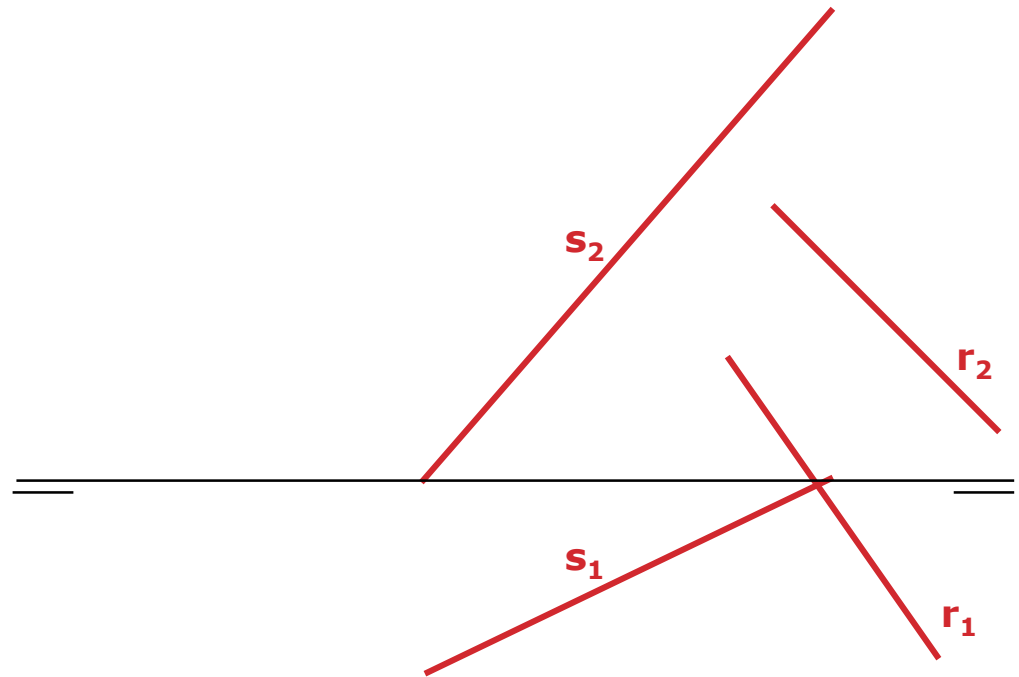
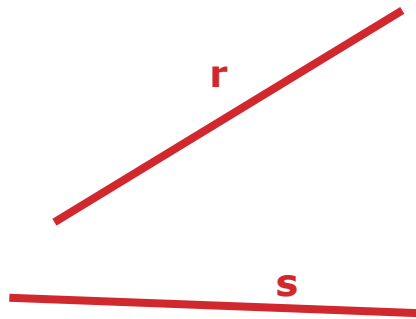

Distance between two crossing lines

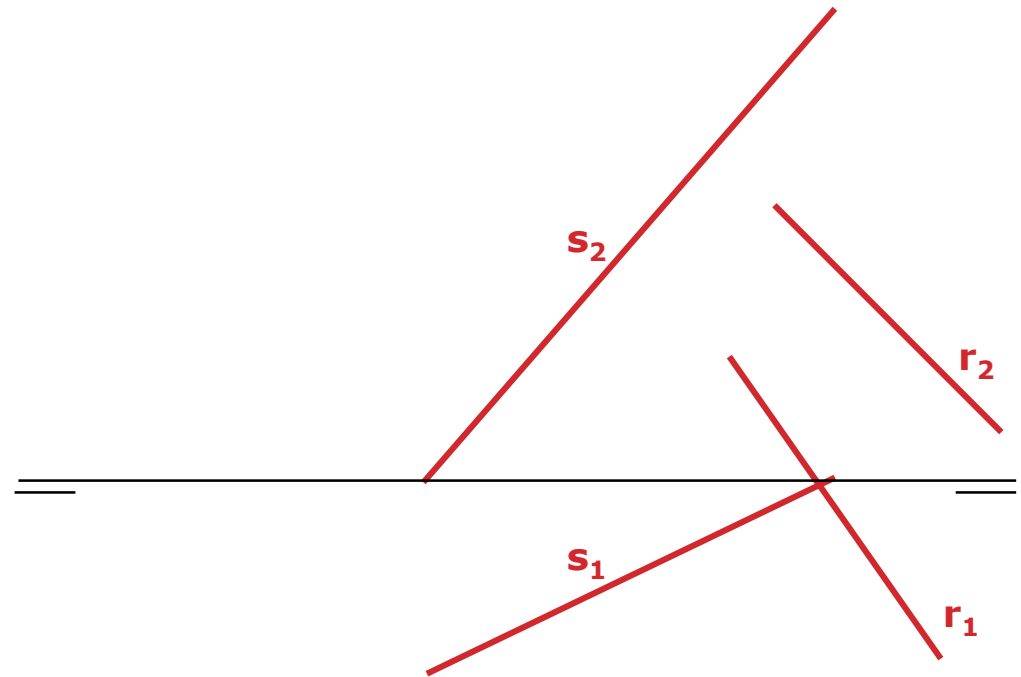
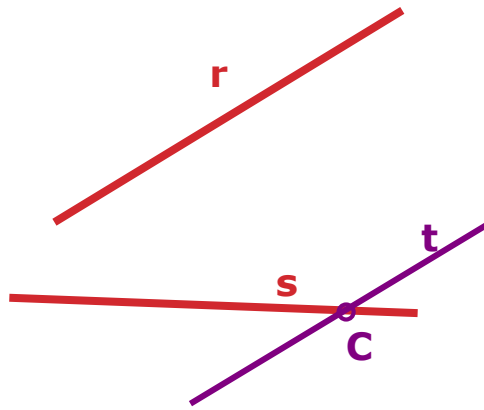

Distance between two crossing lines

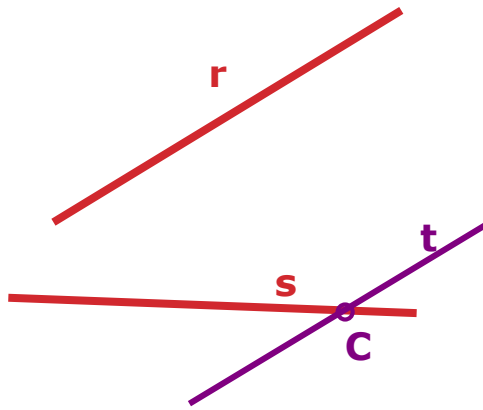

1. Draw line $t \parallel r$ passing through a point C that belongs to s

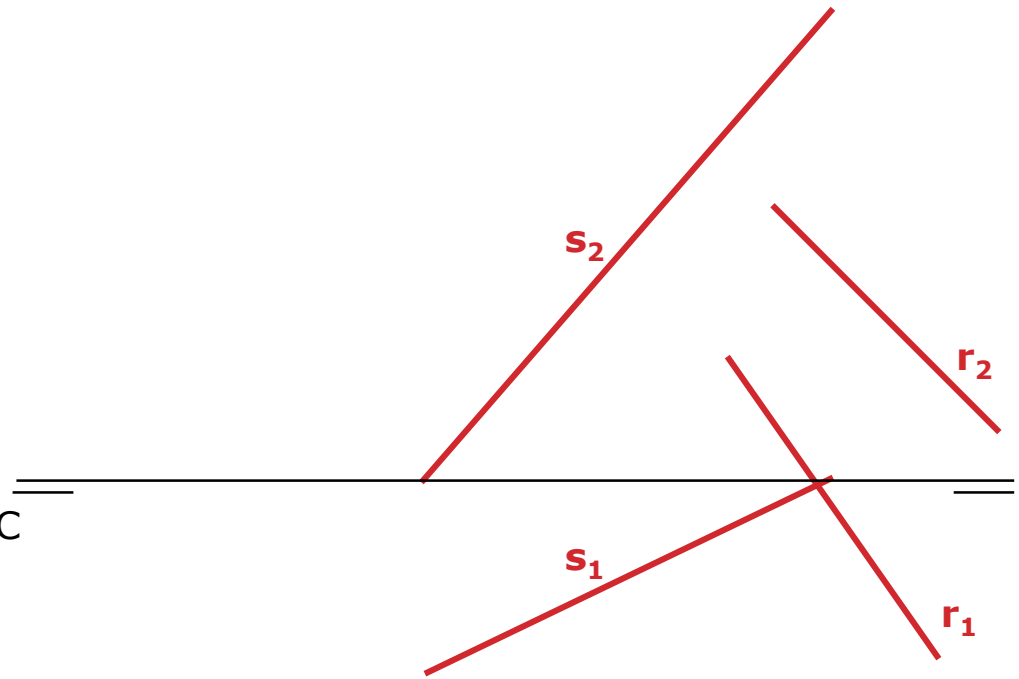

Distance between two crossing lines

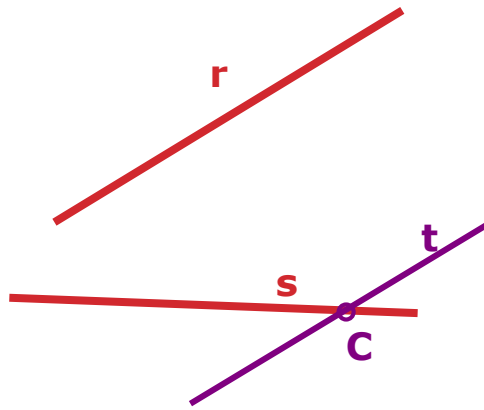

1. Draw line $t \parallel r$ passing through a point C that belongs to s

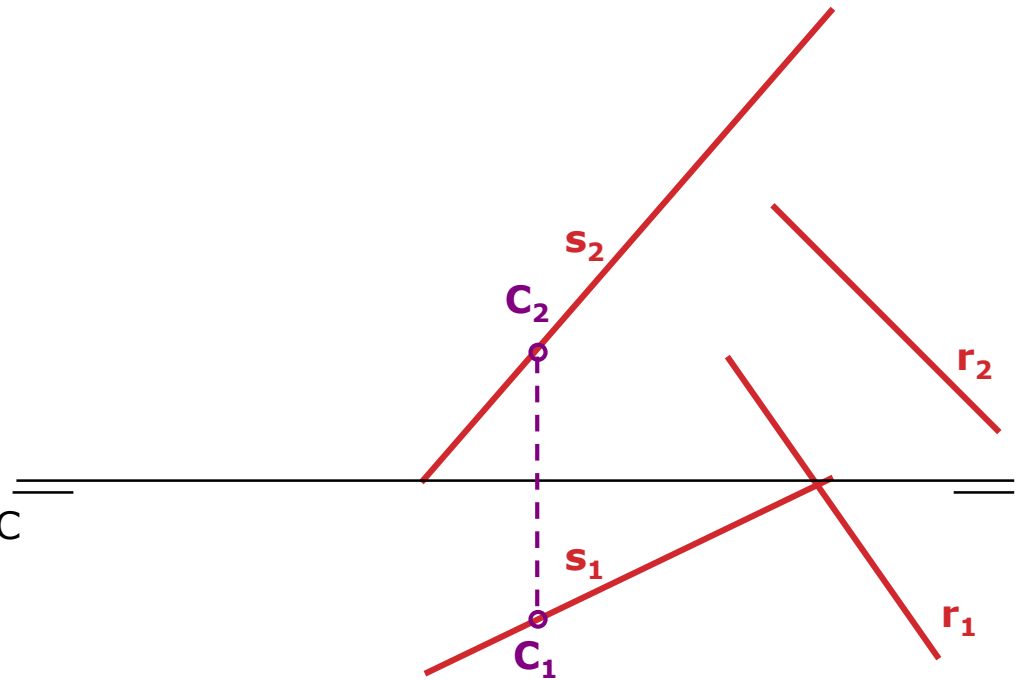

Distance between two crossing lines

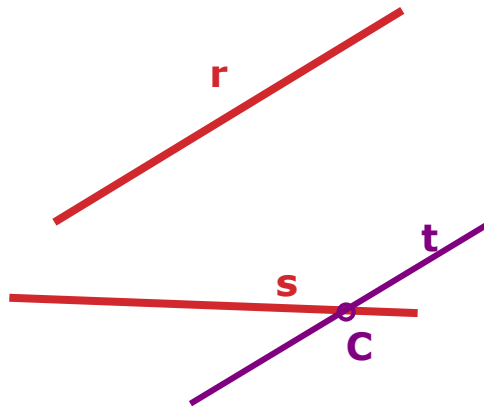

1. Draw line $t \parallel r$ passing through a point C that belongs to s

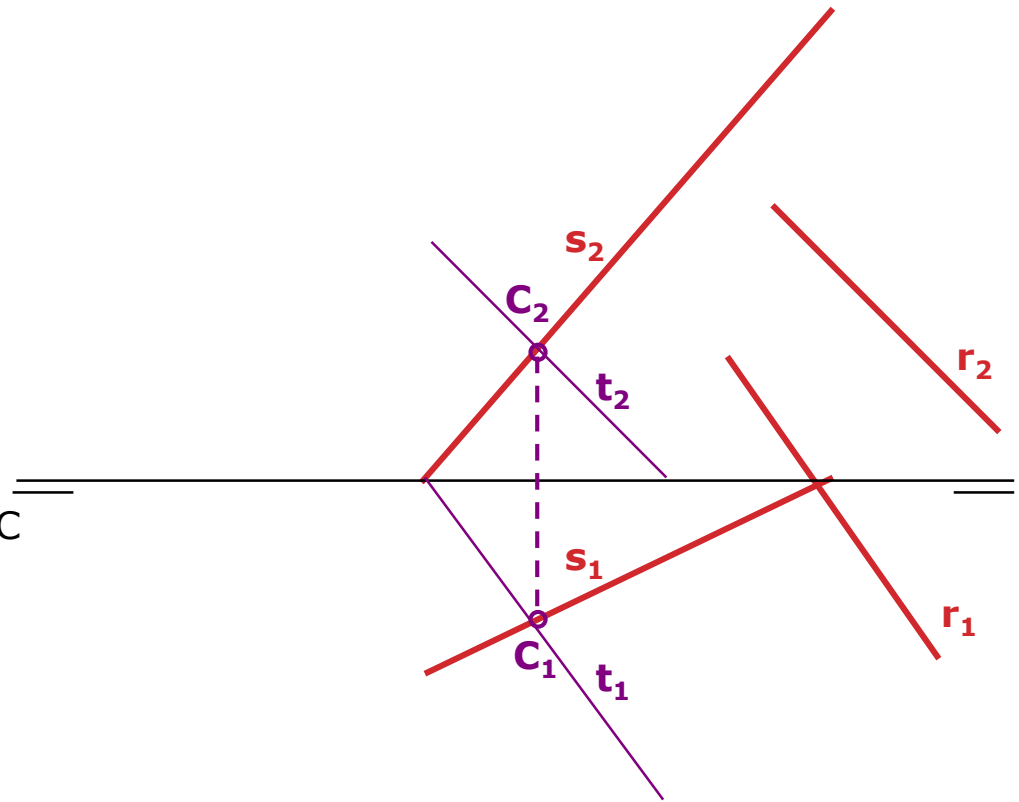

Distance between two crossing lines

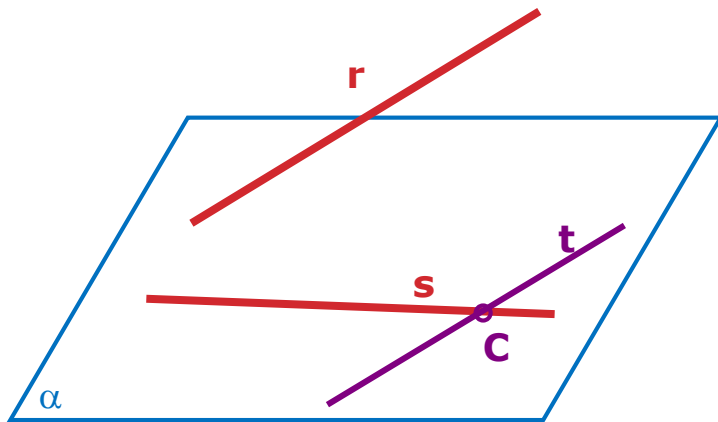

1. Draw line $t // r$ passing through a point C that belongs to s

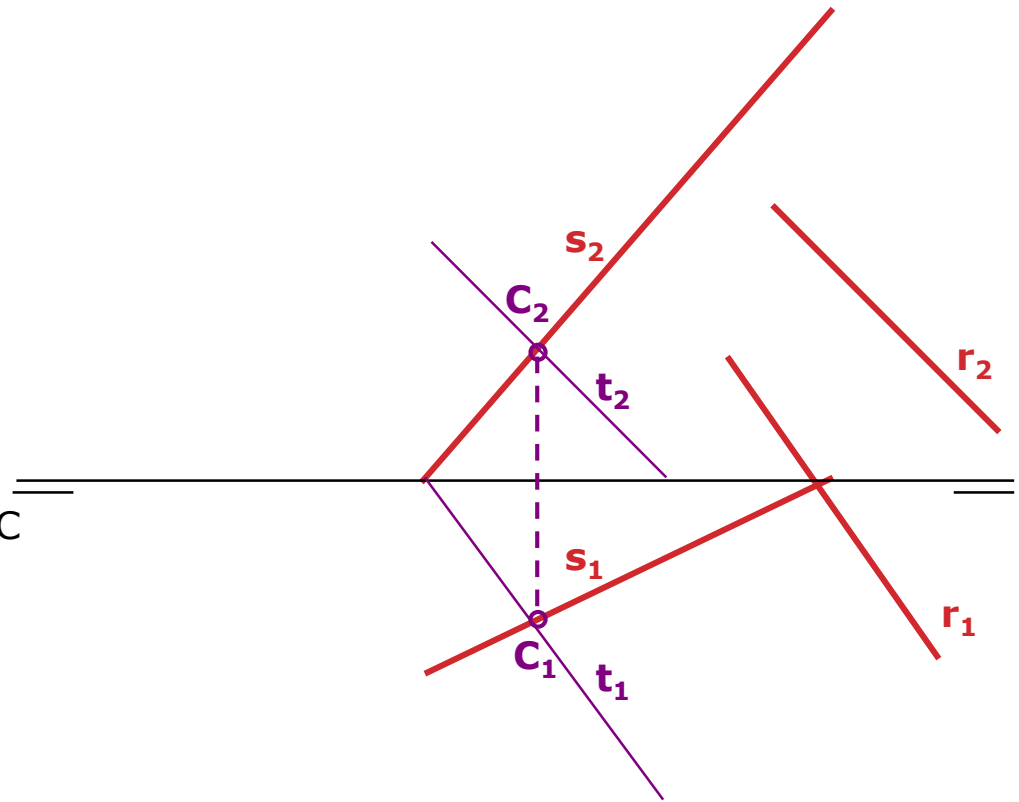

Distance between two crossing lines

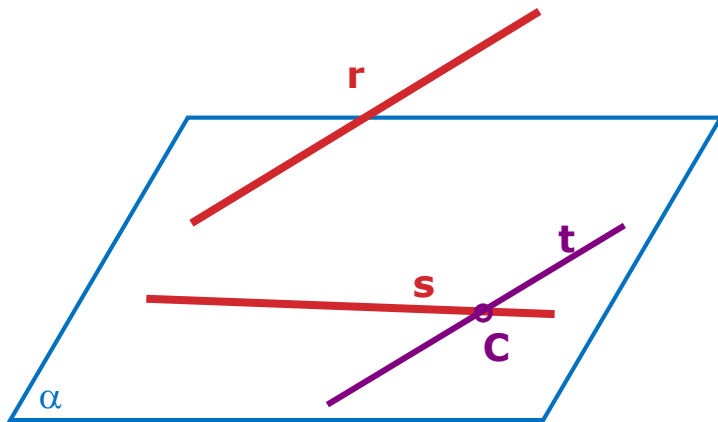

1. Draw line $t // r$ passing through a point C that belongs to s
2. Find plane α that contains s & t and $//$ to r

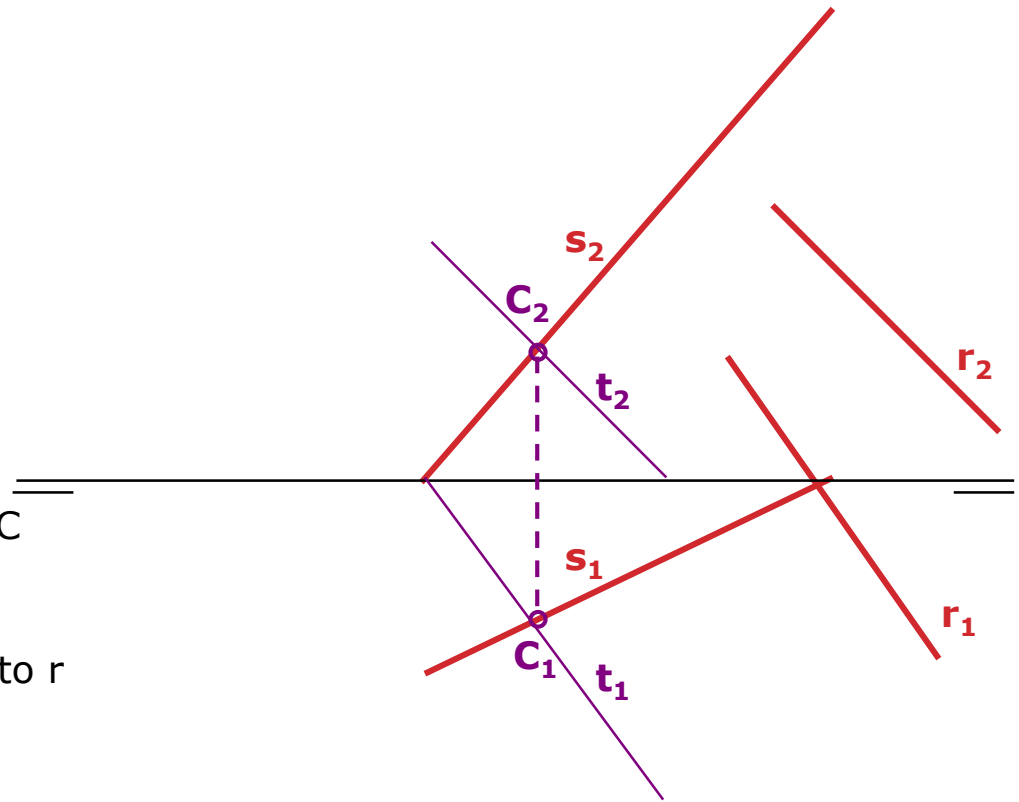

Distance between two crossing lines

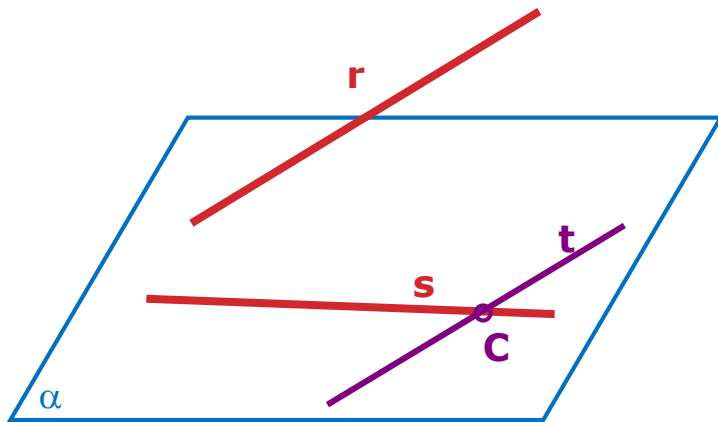

1. Draw line $t//r$ passing through a point C that belongs to s
2. Find plane α that contains s & t and $//$ to r

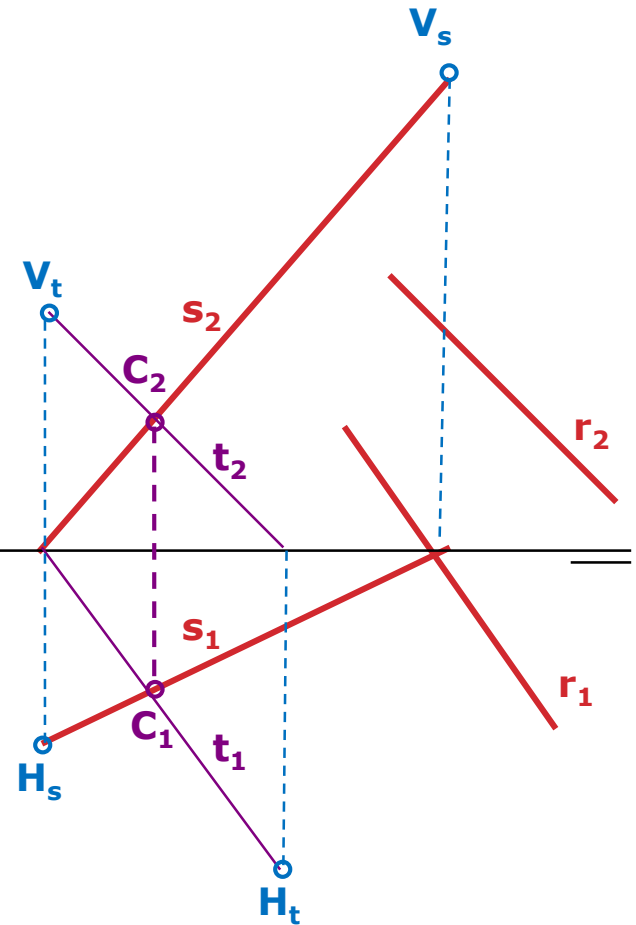

Distance between two crossing lines

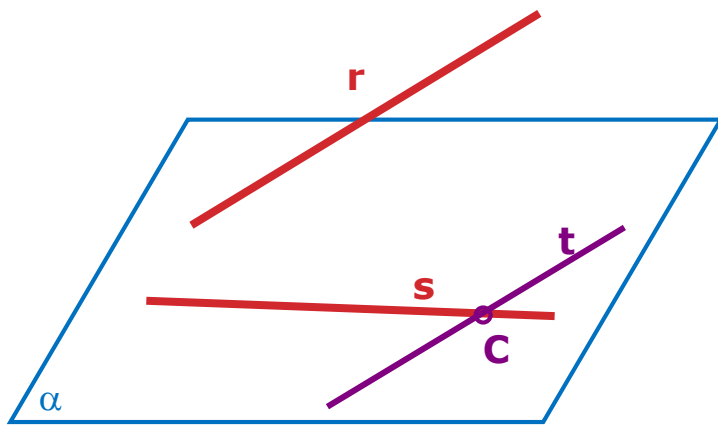

1. Draw line $t//r$ passing through a point C that belongs to s
2. Find plane α that contains s & t and $//$ to r

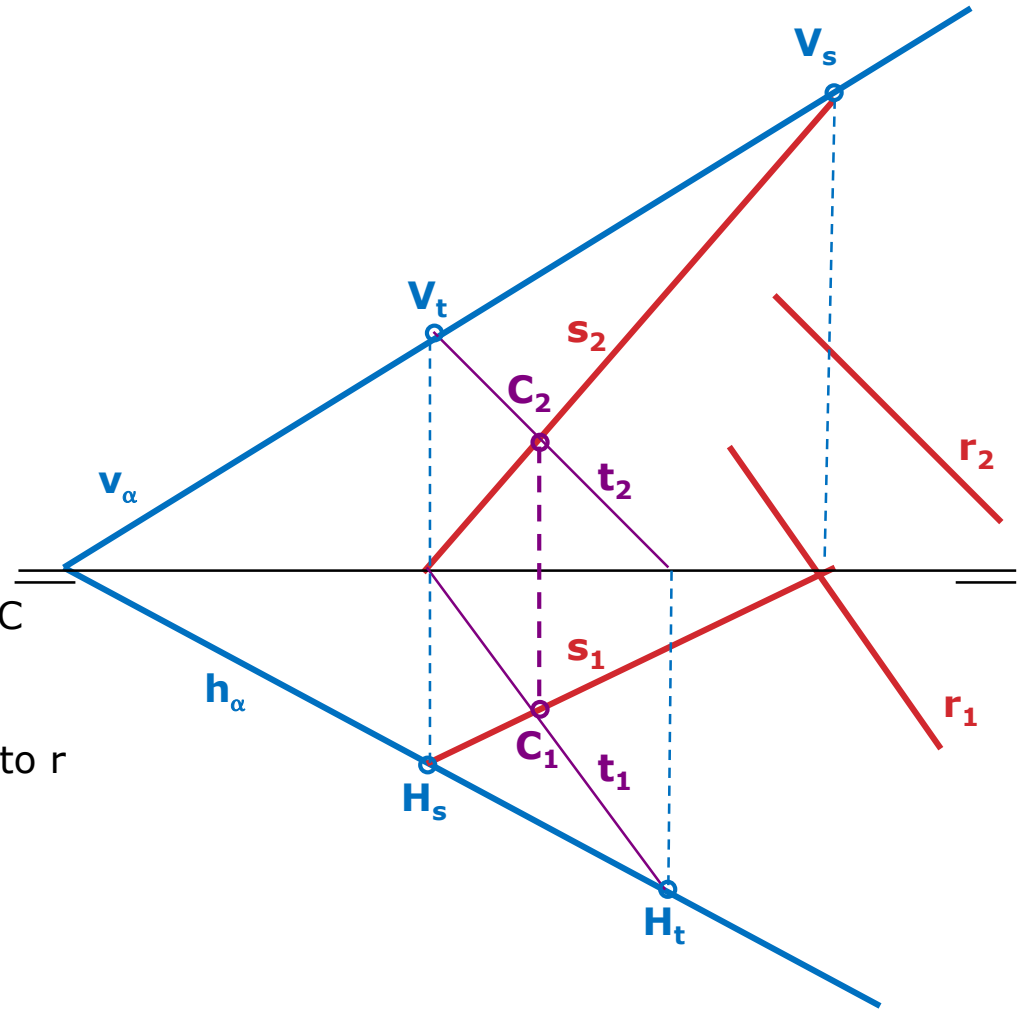

Distance between two crossing lines

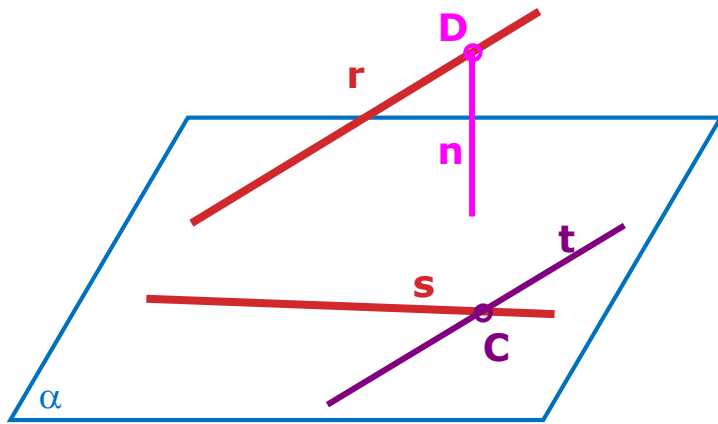

1. Draw line $t // r$ passing through a point C that belongs to s
2. Find plane α that contains s & t and $//$ to r

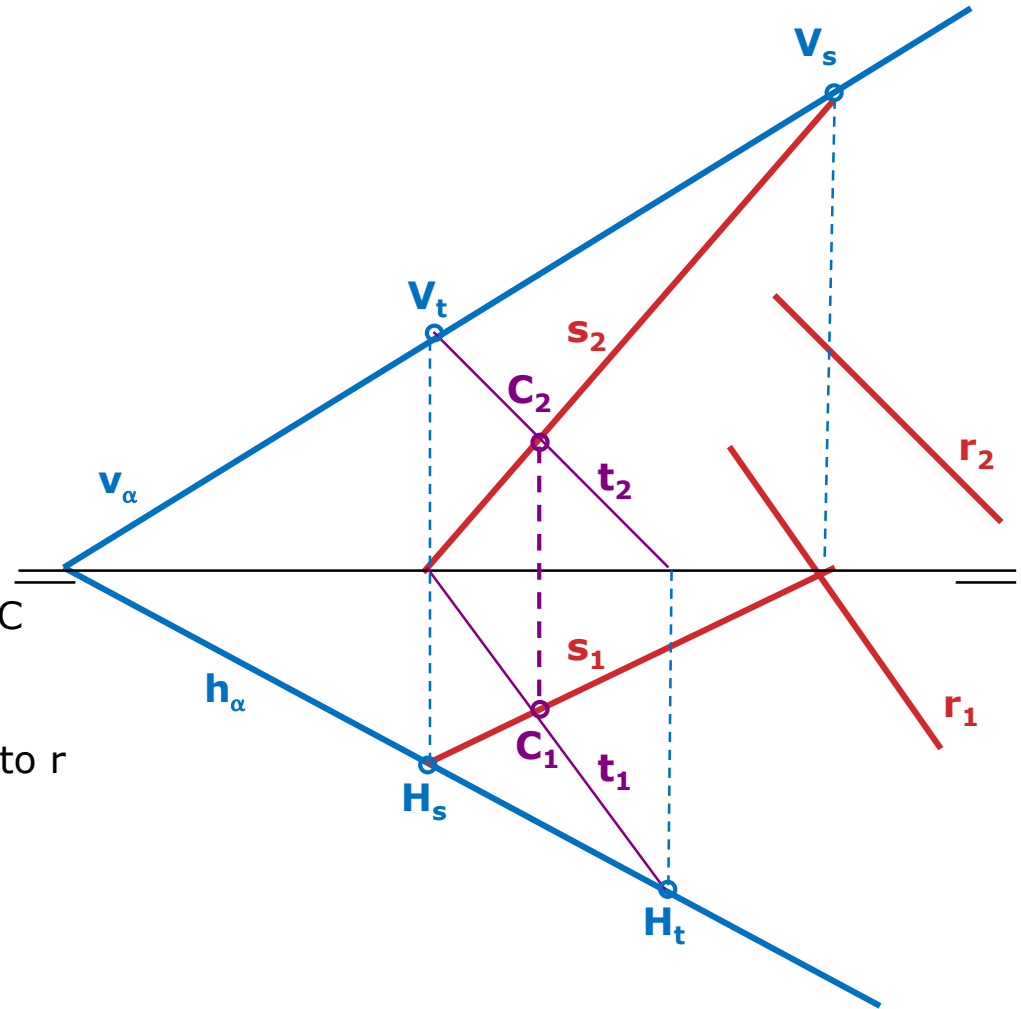

Distance between two crossing lines

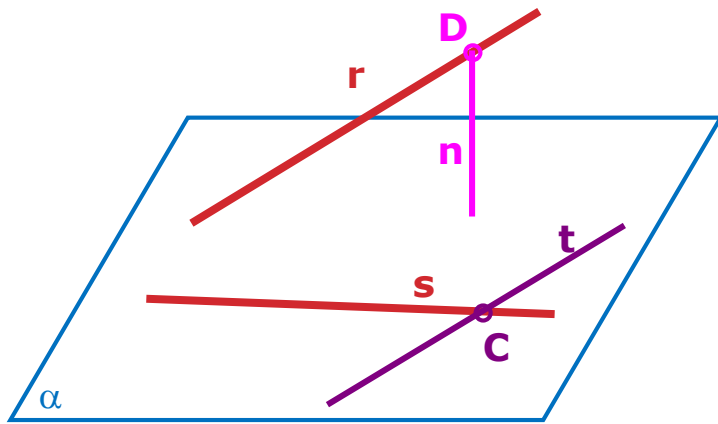

1. Draw line $t//r$ passing through a point C that belongs to s
2. Find plane α that contains s & t and $//$ to r
3. Draw $n \perp \alpha$ and cuts r at point D

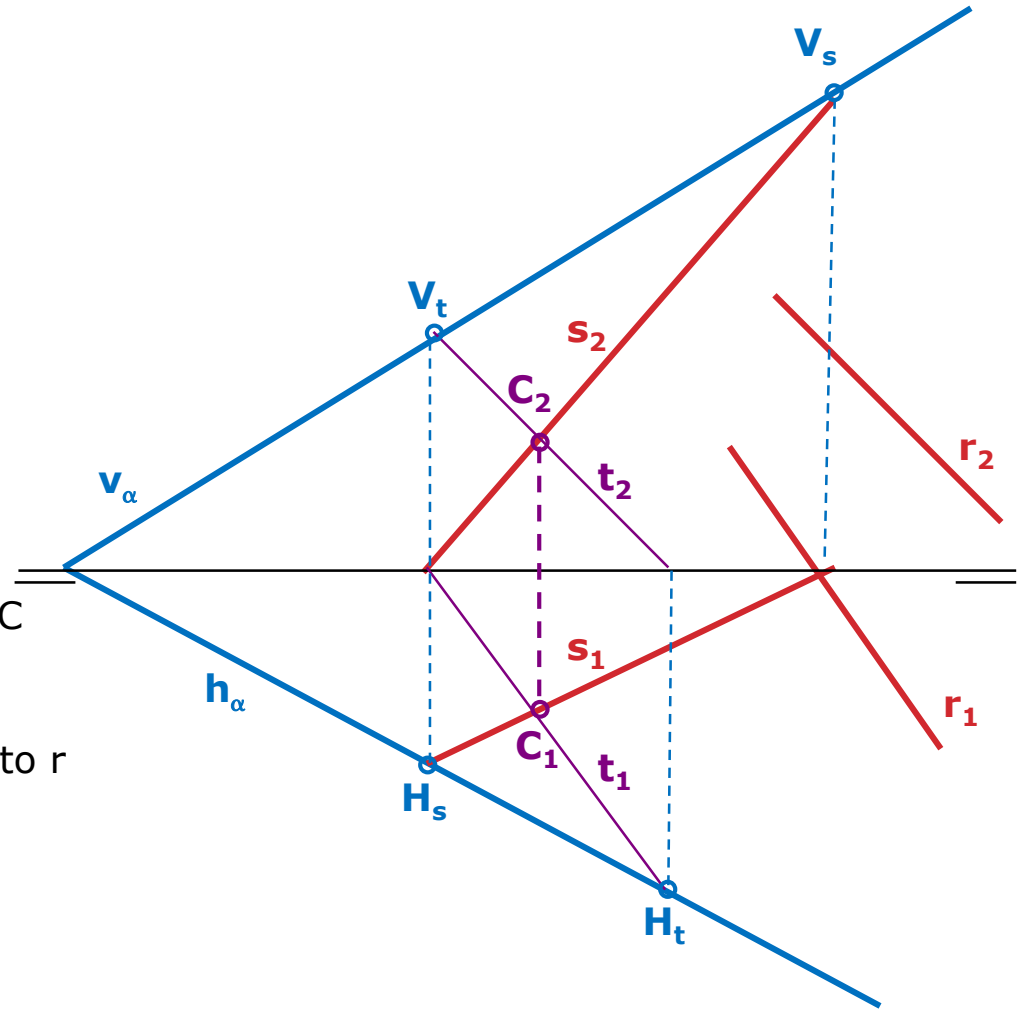

Distance between two crossing lines

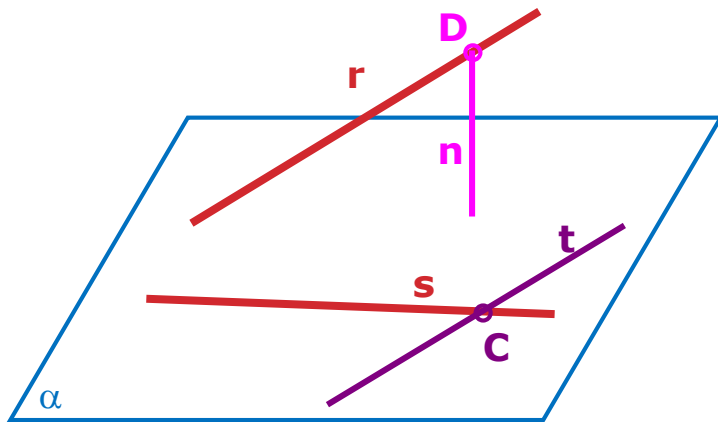

1. Draw line $t//r$ passing through a point C that belongs to s
2. Find plane α that contains s & t and $//$ to r
3. Draw $n \perp \alpha$ and cuts r at point D

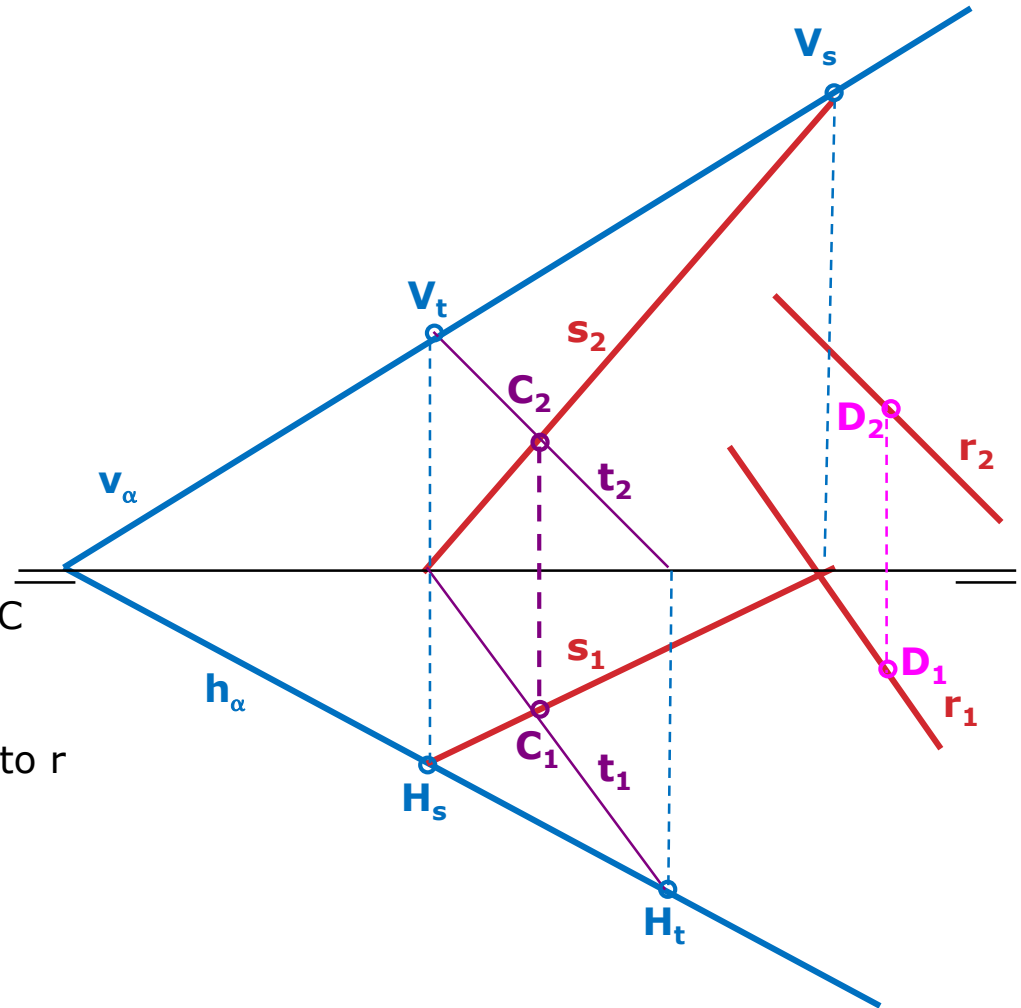

Distance between two crossing lines

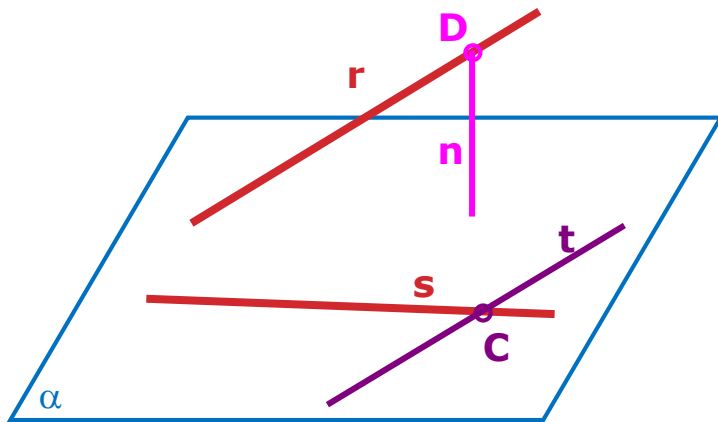

1. Draw line $t//r$ passing through a point C that belongs to s
2. Find plane α that contains s & t and $//$ to r
3. Draw $n \perp \alpha$ and cuts r at point D

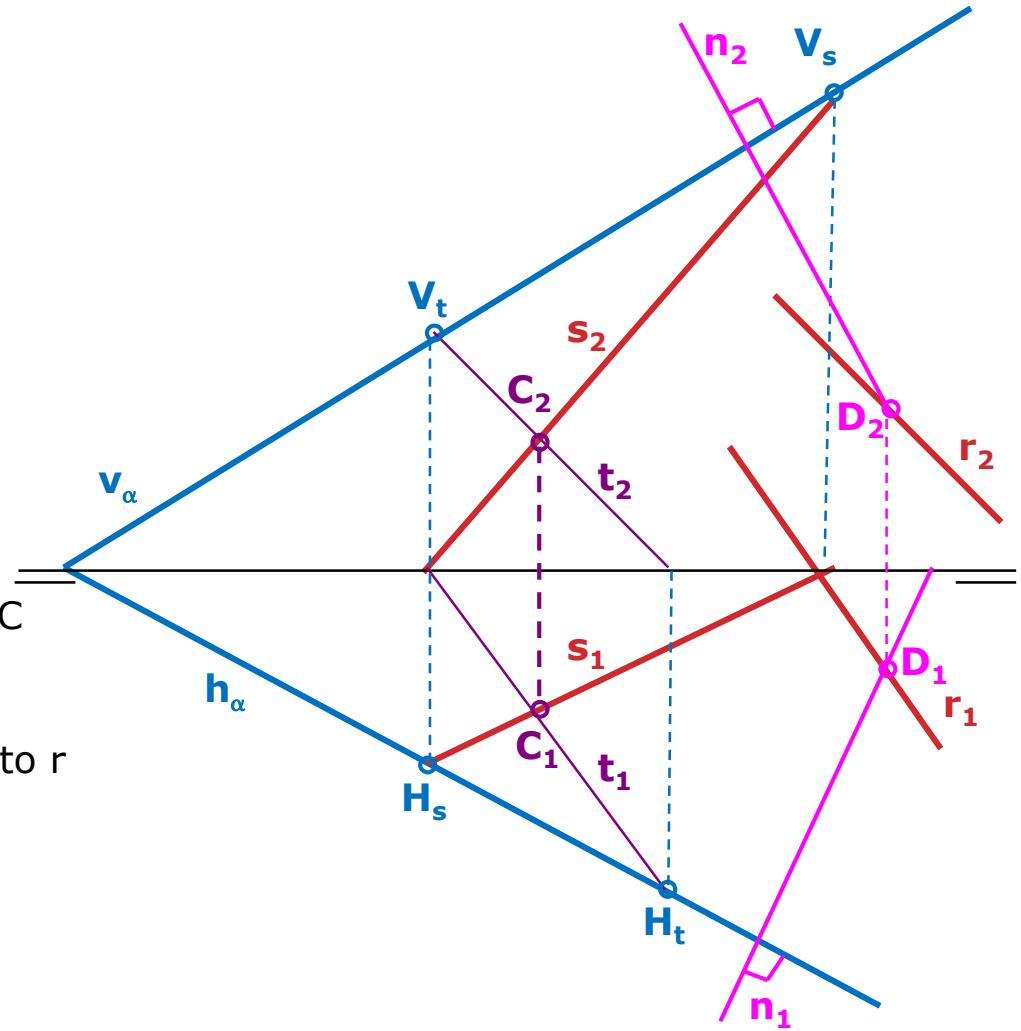

Distance between two crossing lines

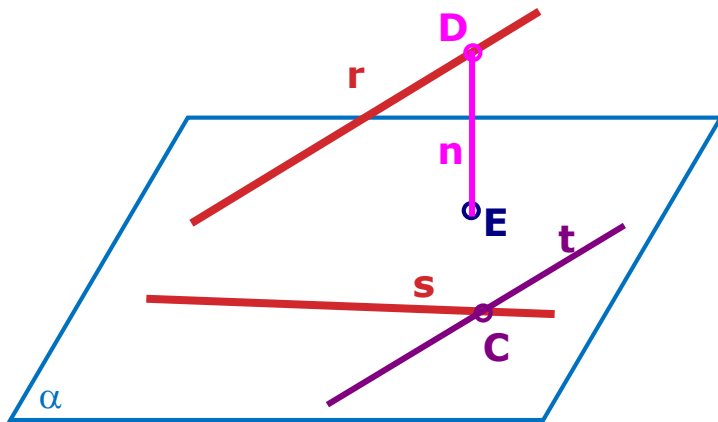

1. Draw line $t//r$ passing through a point C that belongs to s
2. Find plane α that contains s & t and $//$ to r
3. Draw $n \perp \alpha$ and cuts r at point D

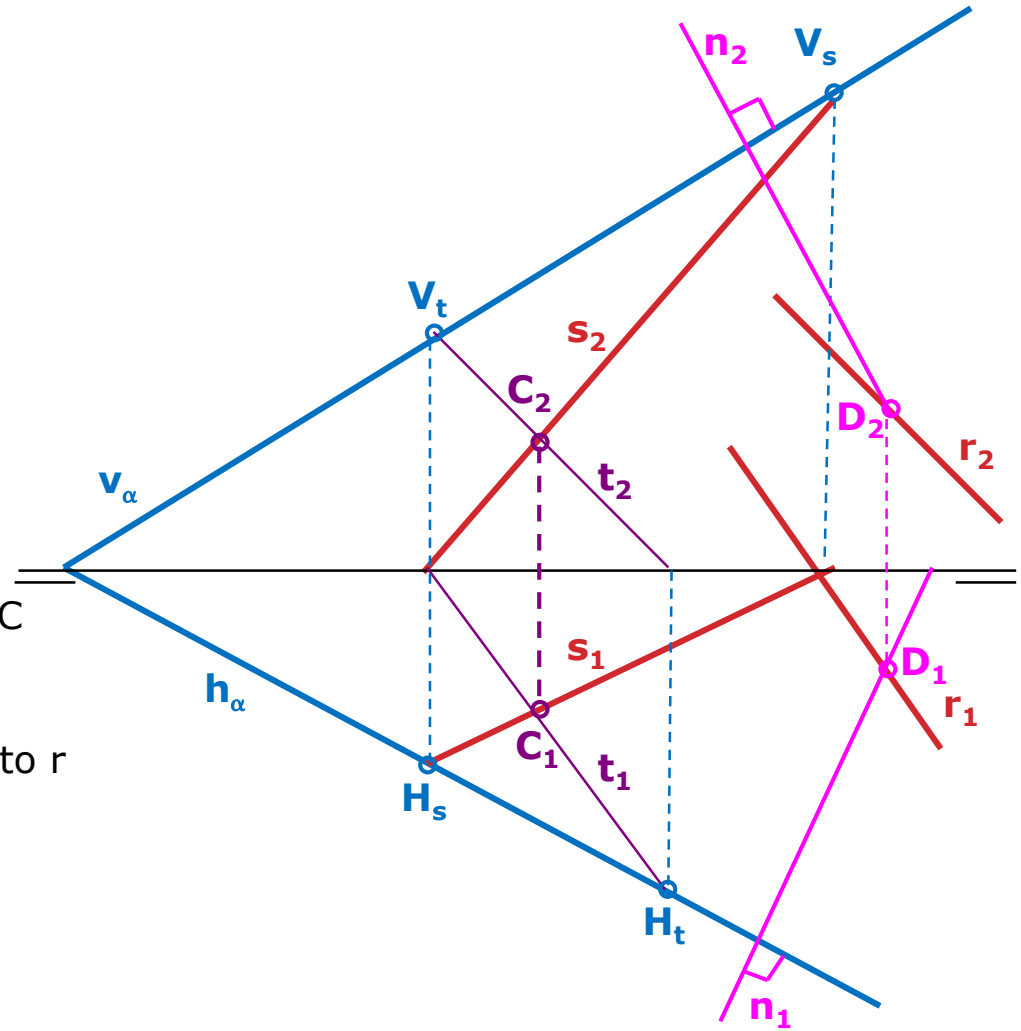

Distance between two crossing lines

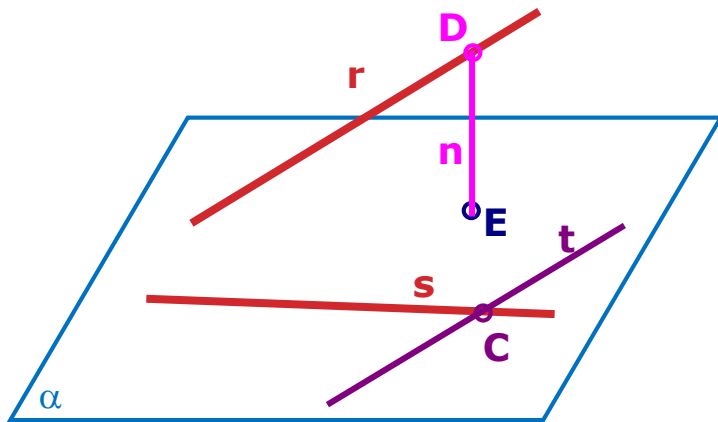

1. Draw line $t // r$ passing through a point C that belongs to s
2. Find plane α that contains s & t and $//$ to r
3. Draw $n \perp \alpha$ and cuts r at point D
4. Find $n \cap \alpha = E$

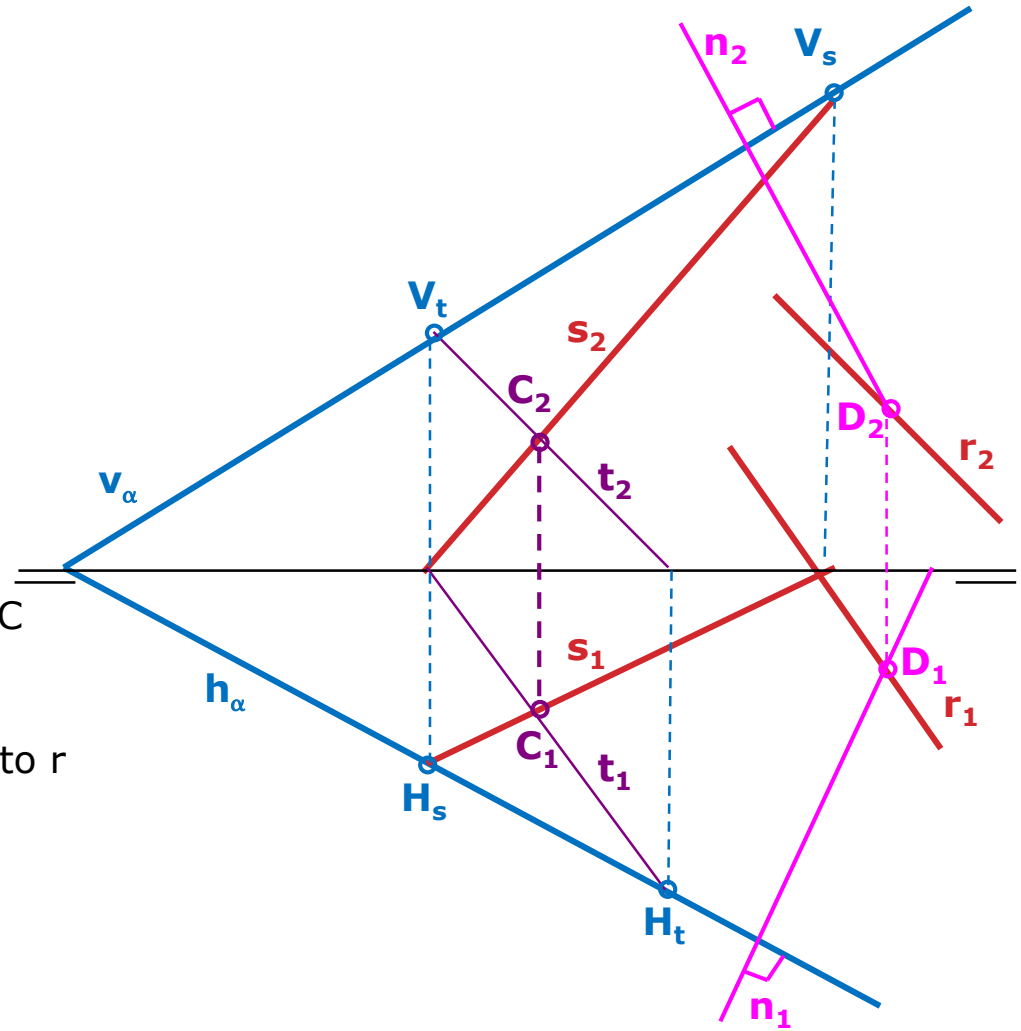

Distance between two crossing lines

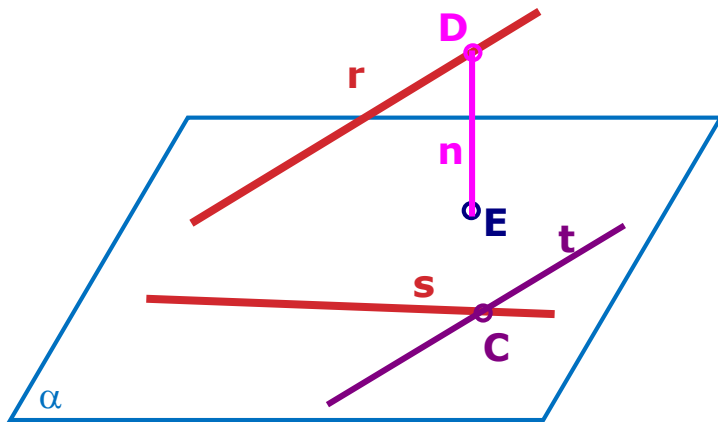

1. Draw line $t//r$ passing through a point C that belongs to s
2. Find plane α that contains s & t and $//$ to r
3. Draw $n \perp \alpha$ and cuts r at point D
4. Find $n \cap \alpha = E$

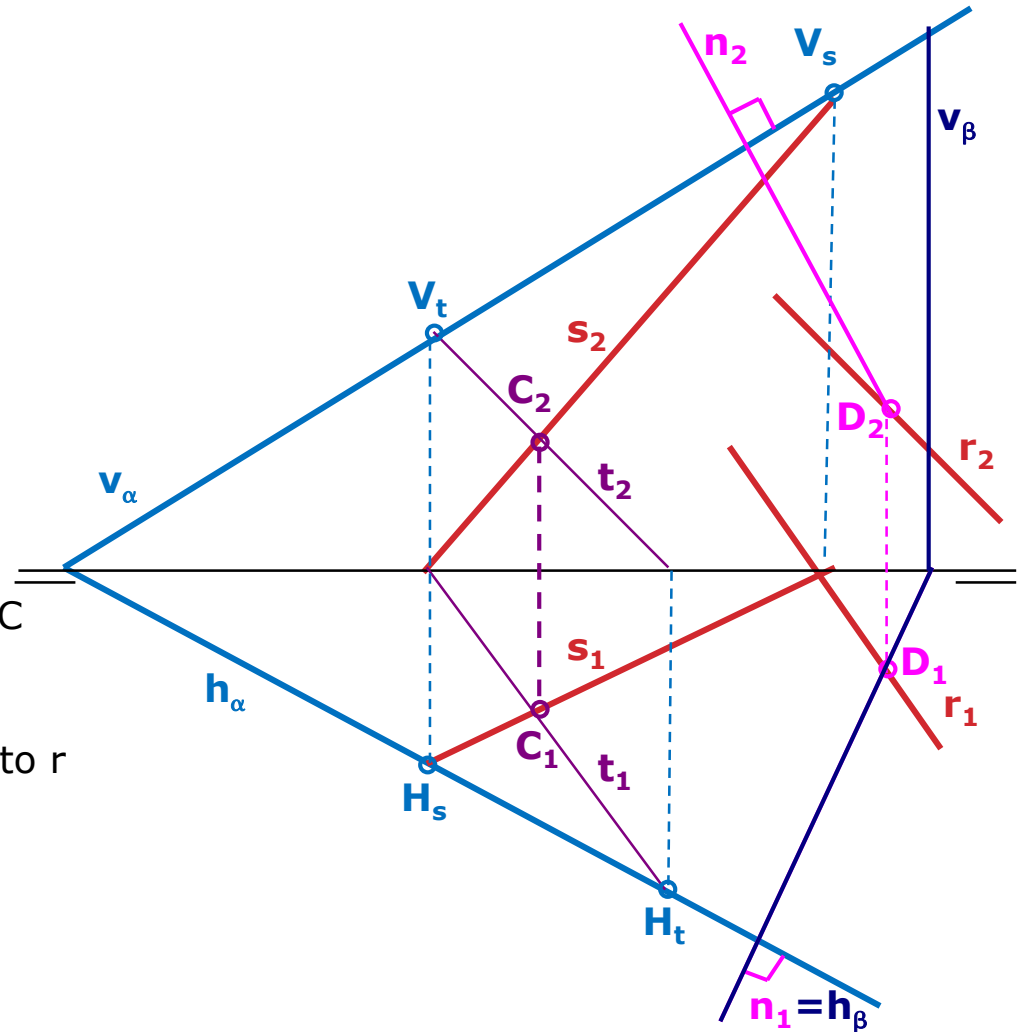

Distance between two crossing lines

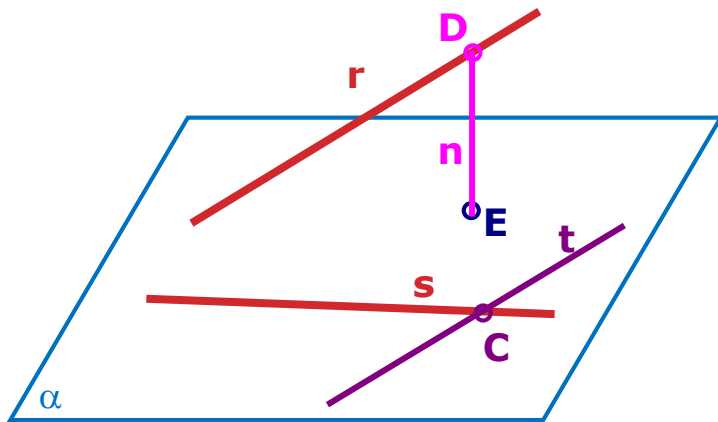

1. Draw line $t//r$ passing through a point C that belongs to s
2. Find plane α that contains s & t and $//$ to r
3. Draw $n \perp \alpha$ and cuts r at point D
4. Find $n \cap \alpha = E$

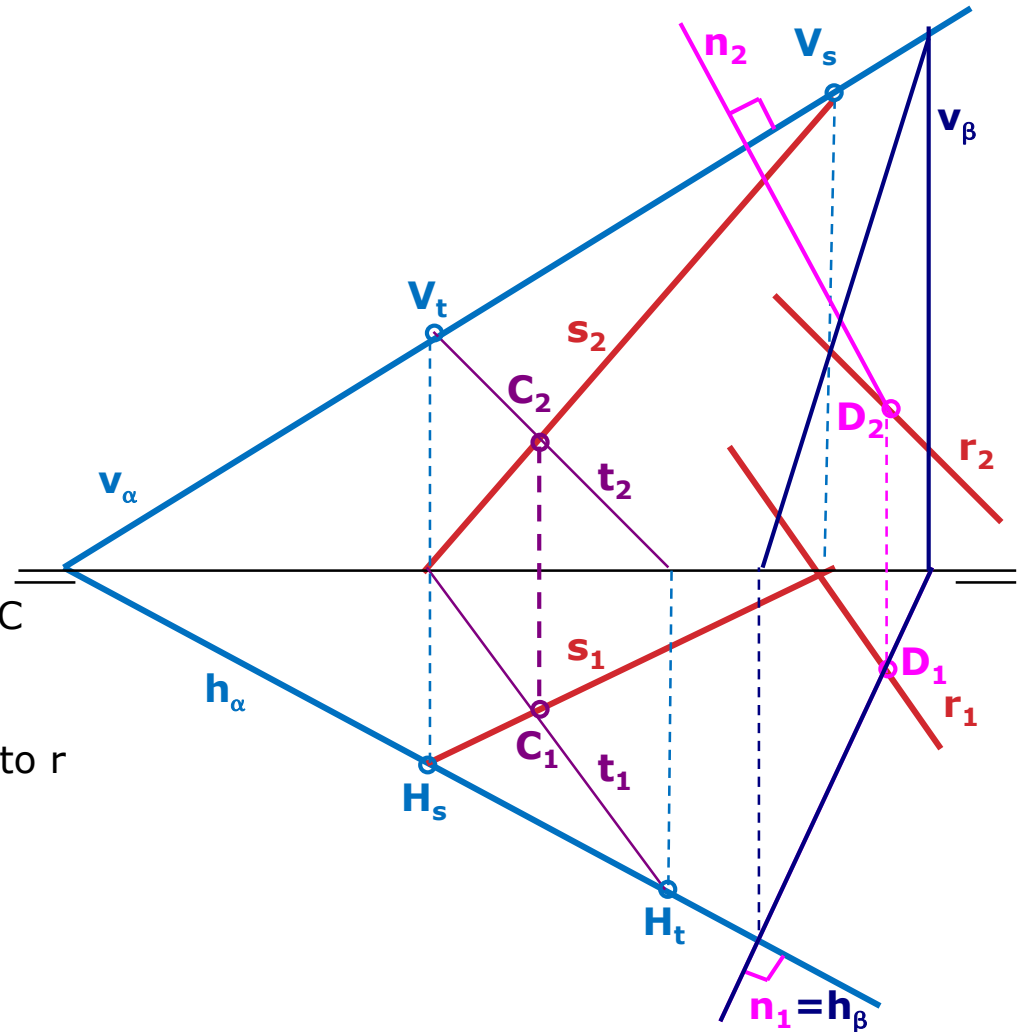

Distance between two crossing lines

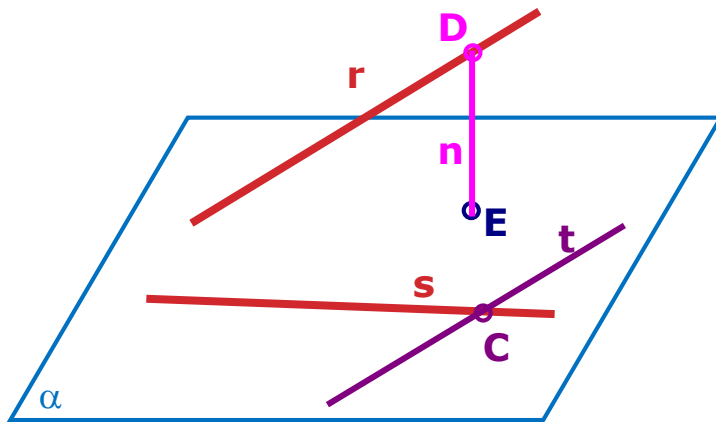

1. Draw line $t//r$ passing through a point C that belongs to s
2. Find plane α that contains s & t and $//$ to r
3. Draw $n \perp \alpha$ and cuts r at point D
4. Find $n \cap \alpha = E$

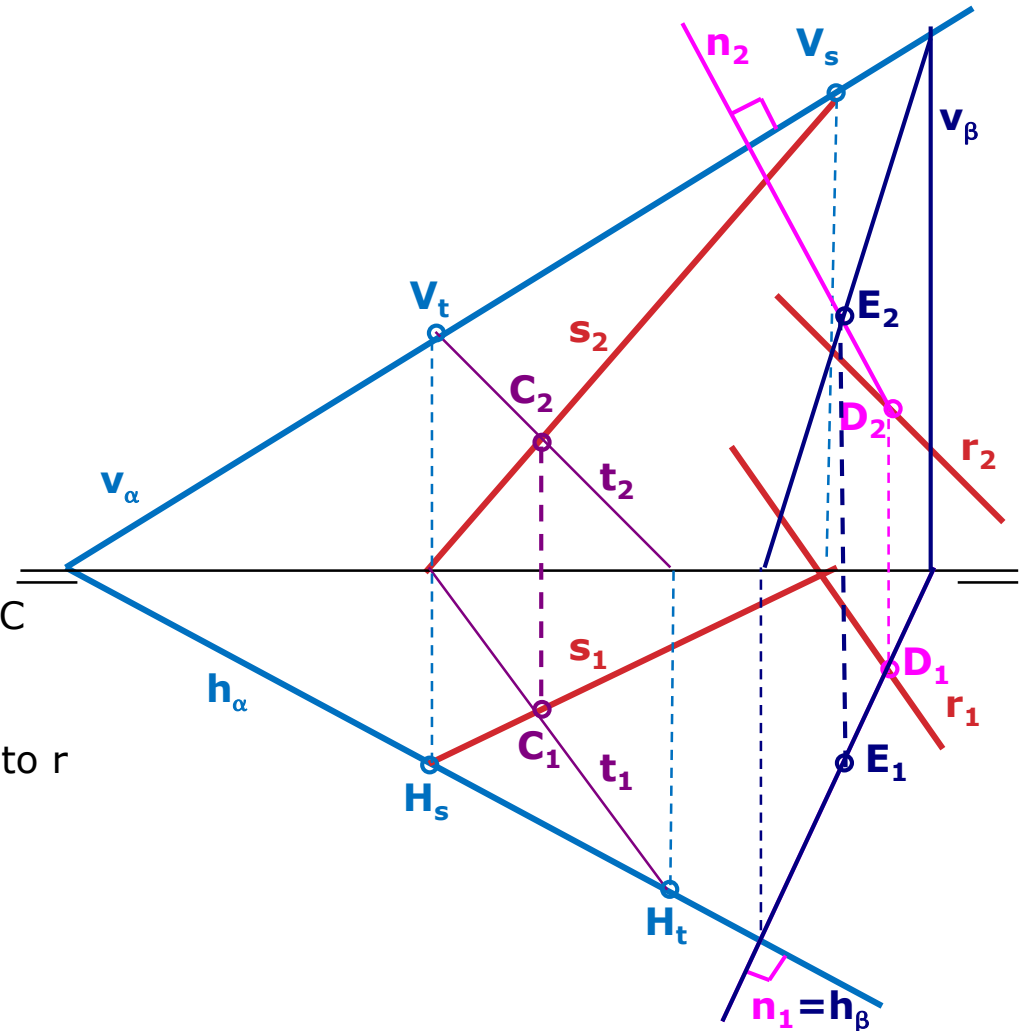

Distance between two crossing lines

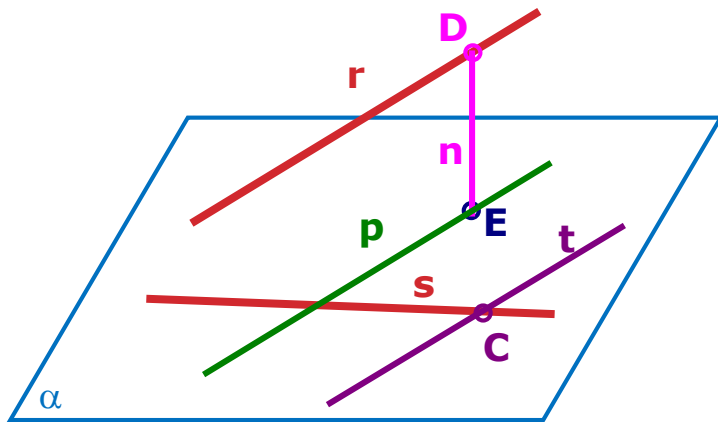

1. Draw line $t//r$ passing through a point C that belongs to s
2. Find plane α that contains s & t and $//$ to r
3. Draw $n \perp \alpha$ and cuts r at point D
4. Find $n \cap \alpha = E$

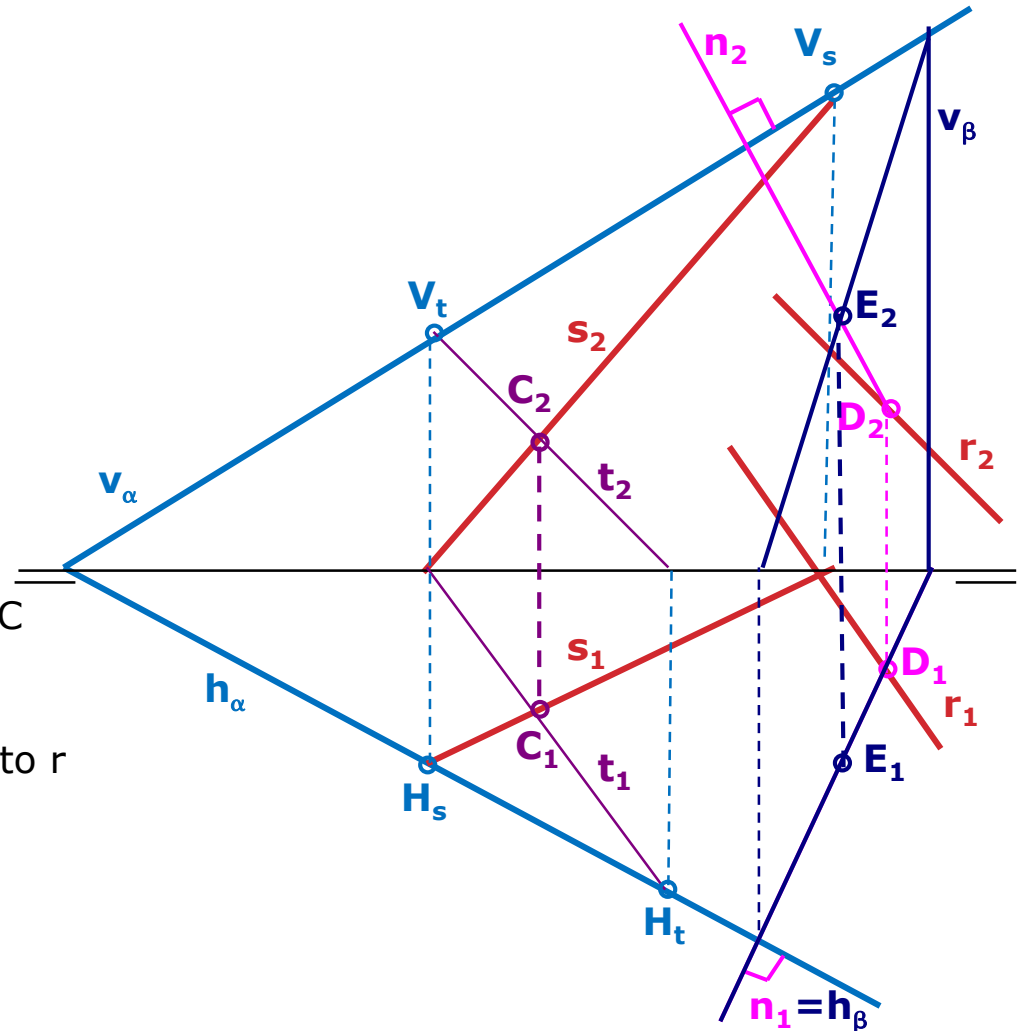

Distance between two crossing lines

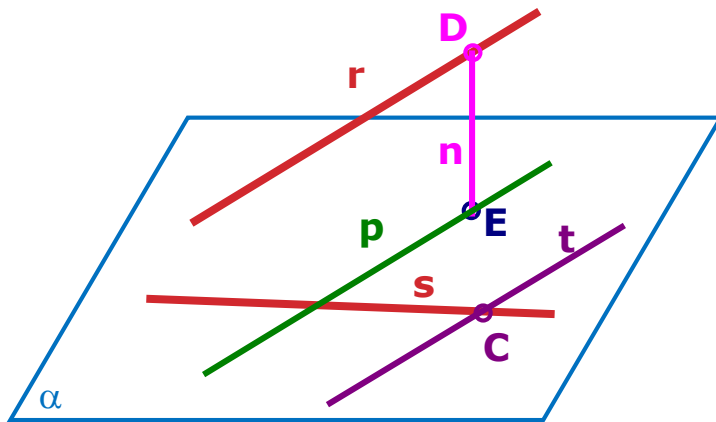

1. Draw line $t//r$ passing through a point C that belongs to s
2. Find plane α that contains s & t and $//$ to r
3. Draw $n \perp \alpha$ and cuts r at point D
4. Find $n \cap \alpha = E$
5. Draw a line $p//r$ and passes through E

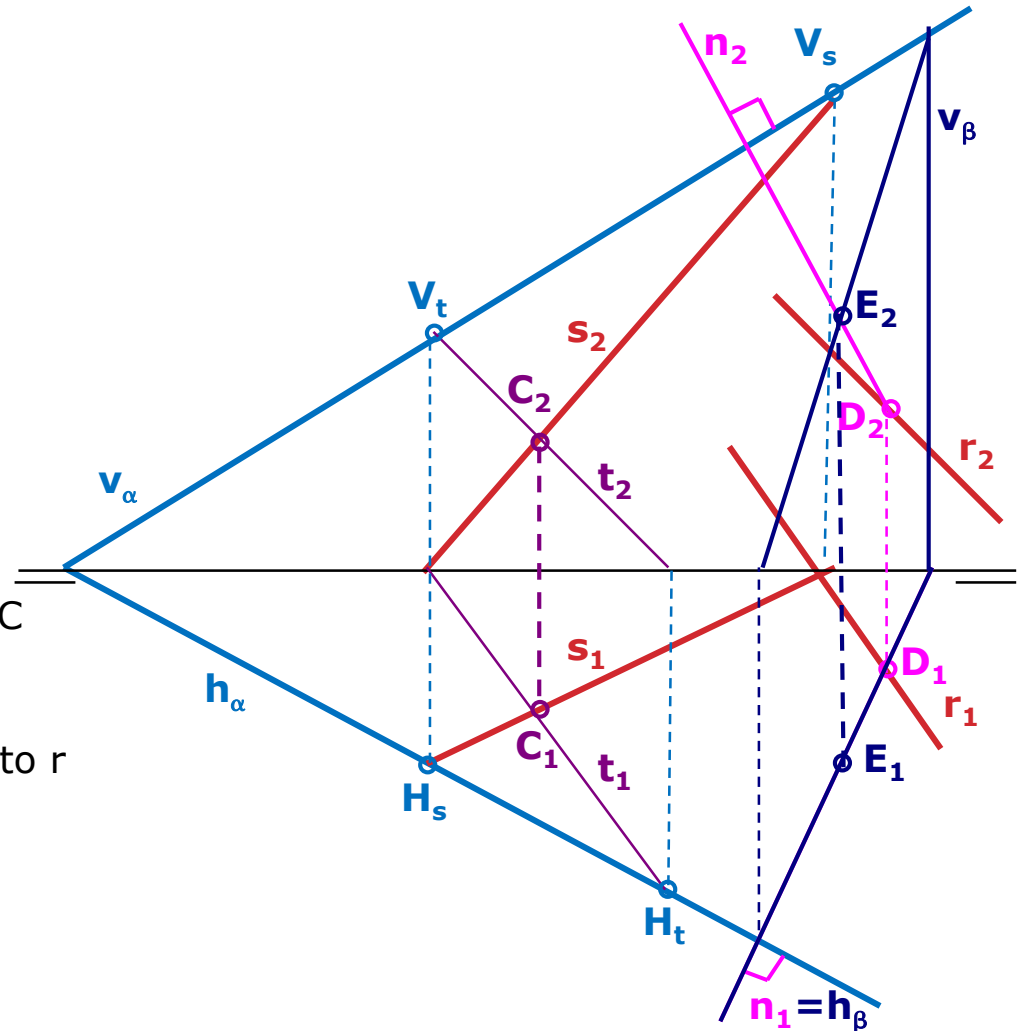

Distance between two crossing lines

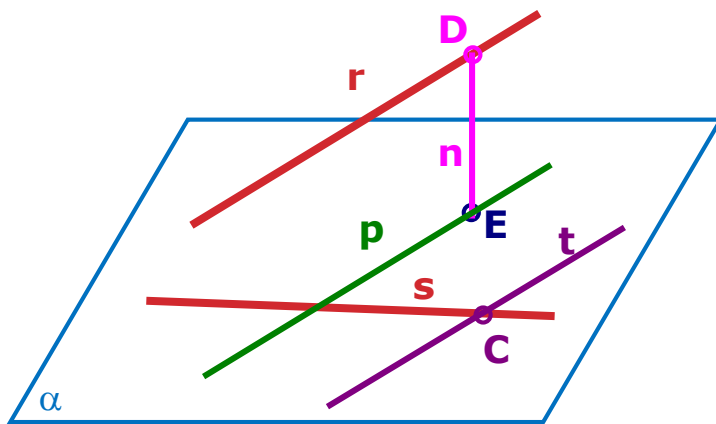

1. Draw line $t//r$ passing through a point C that belongs to s
2. Find plane α that contains s & t and $//$ to r
3. Draw $n \perp \alpha$ and cuts r at point D
4. Find $n \cap \alpha = E$
5. Draw a line $p//r$ and passes through E

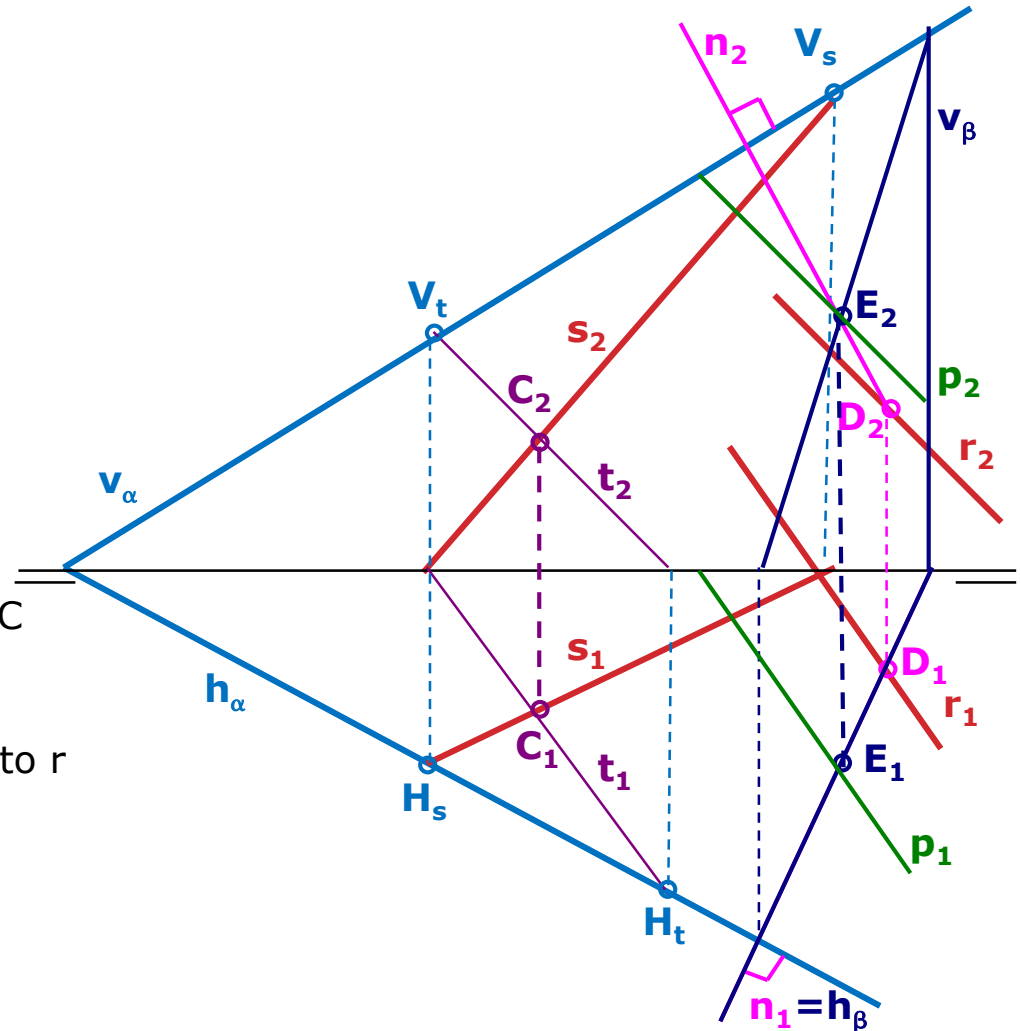

Distance between two crossing lines

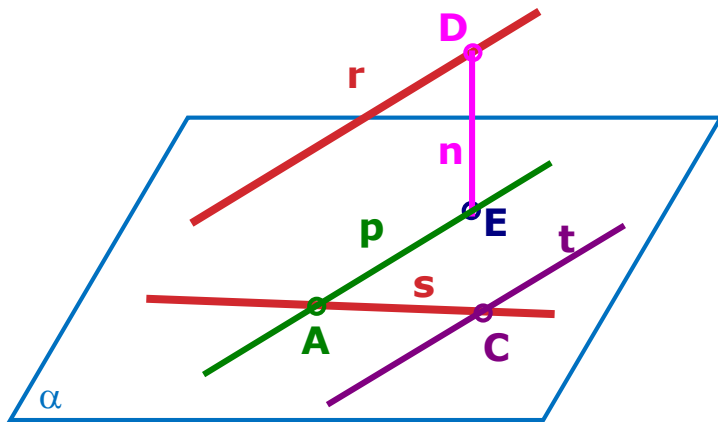

1. Draw line $t // r$ passing through a point C that belongs to s
2. Find plane α that contains s & t and $//$ to r
3. Draw $n \perp \alpha$ and cuts r at point D
4. Find $n \cap \alpha = E$
5. Draw a line $p // r$ and passes through E

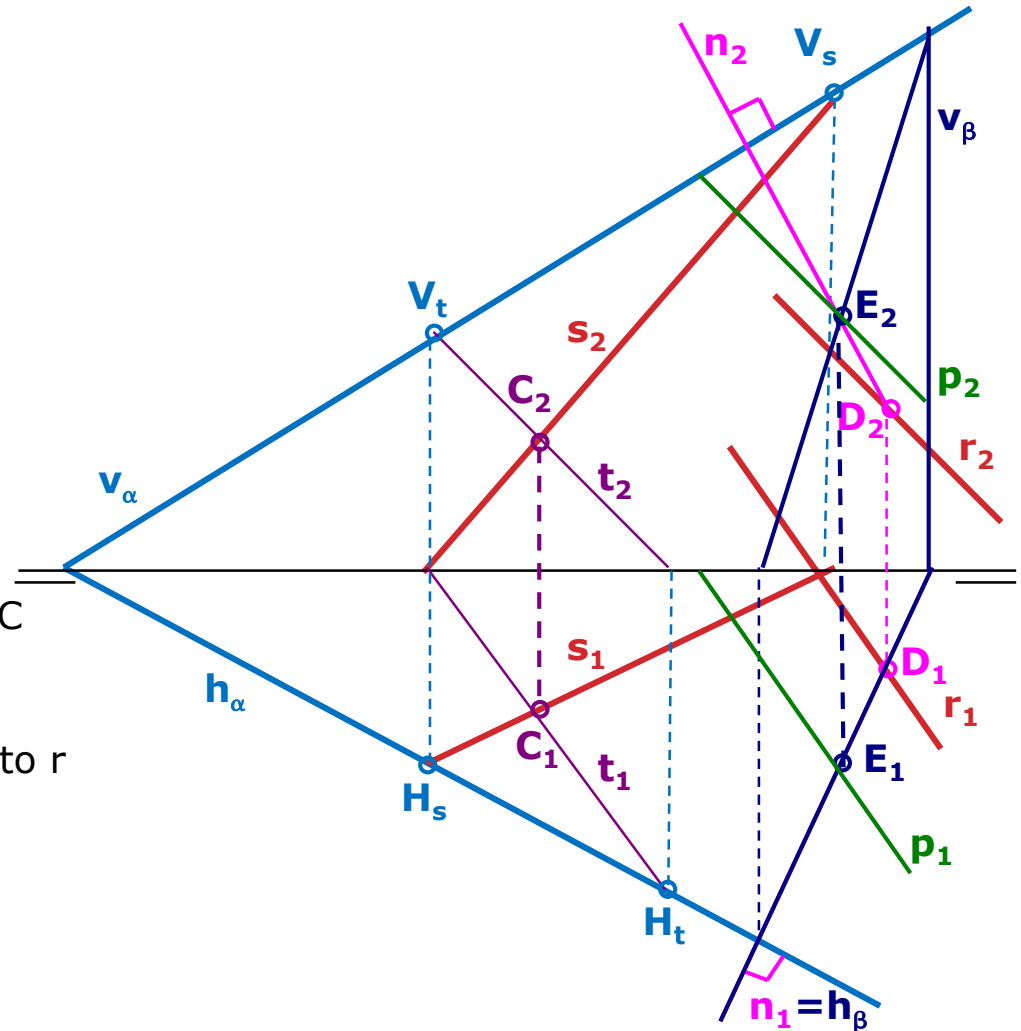

Distance between two crossing lines

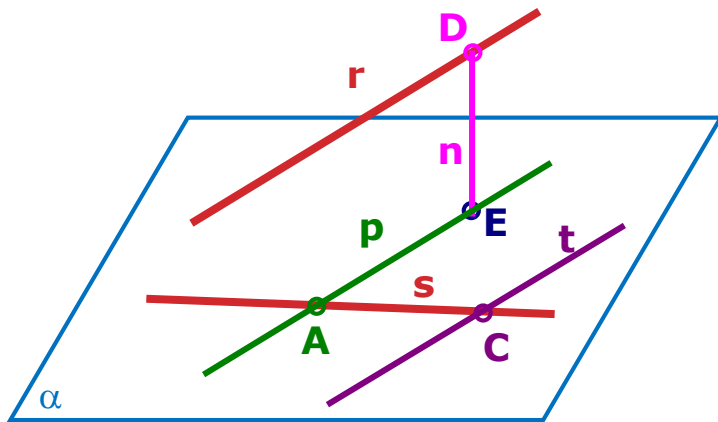

1. Draw line $t // r$ passing through a point C that belongs to s
2. Find plane α that contains s & t and $//$ to r
3. Draw $n \perp \alpha$ and cuts r at point D
4. Find $n \cap \alpha = E$
5. Draw a line $p // r$ and passes through E
6. Calculate $p \cap s = A$

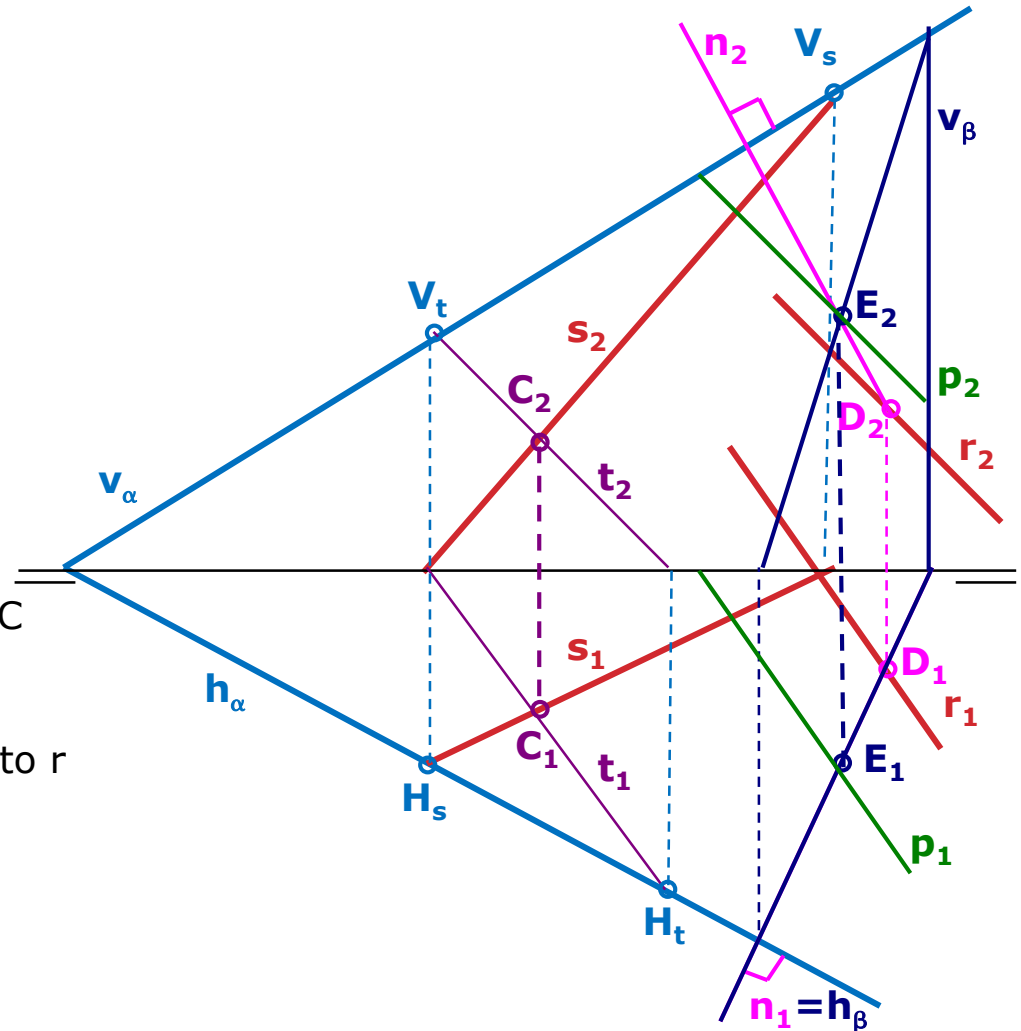

Distance between two crossing lines

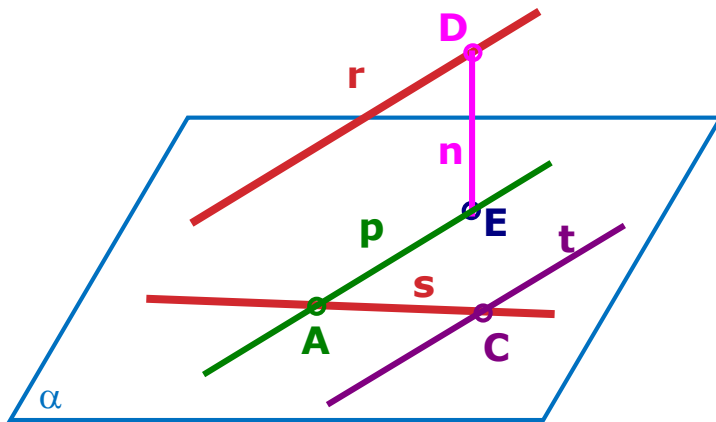

1. Draw line $t // r$ passing through a point C that belongs to s
2. Find plane α that contains s & t and $//$ to r
3. Draw $n \perp \alpha$ and cuts r at point D
4. Find $n \cap \alpha = E$
5. Draw a line $p // r$ and passes through E
6. Calculate $p \cap s = A$

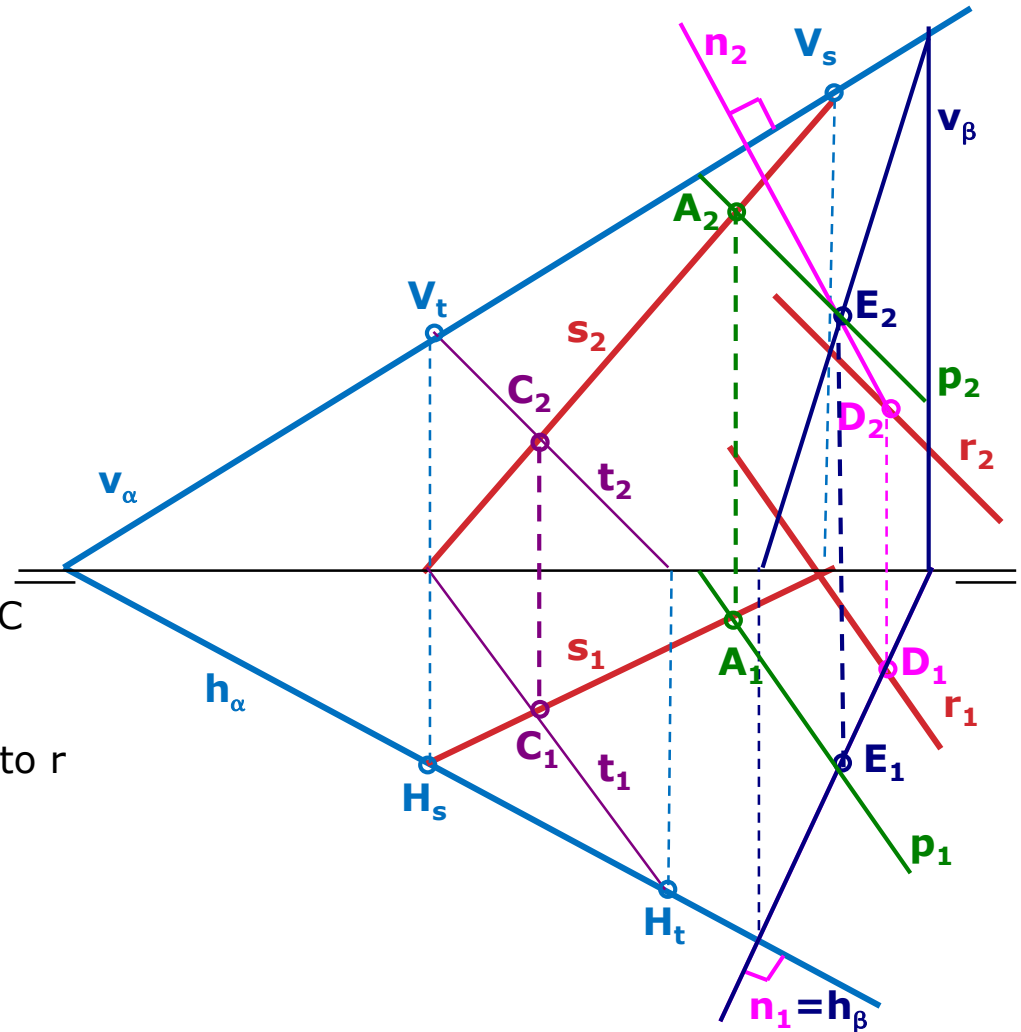

Distance between two crossing lines

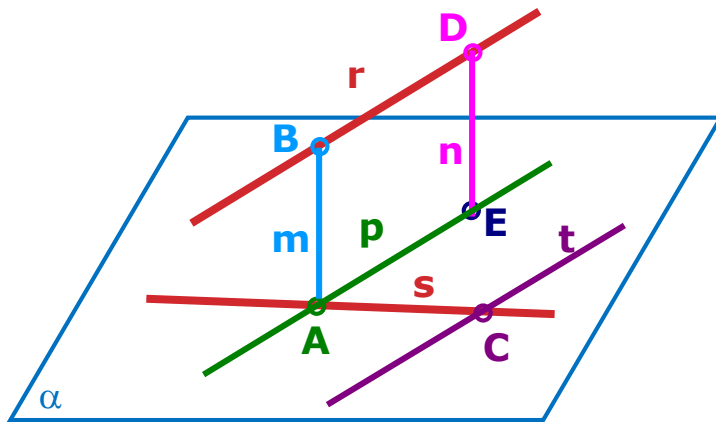

1. Draw line $t // r$ passing through a point C that belongs to s
2. Find plane α that contains s & t and $//$ to r
3. Draw $n \perp \alpha$ and cuts r at point D
4. Find $n \cap \alpha = E$
5. Draw a line $p // r$ and passes through E
6. Calculate $p \cap s = A$

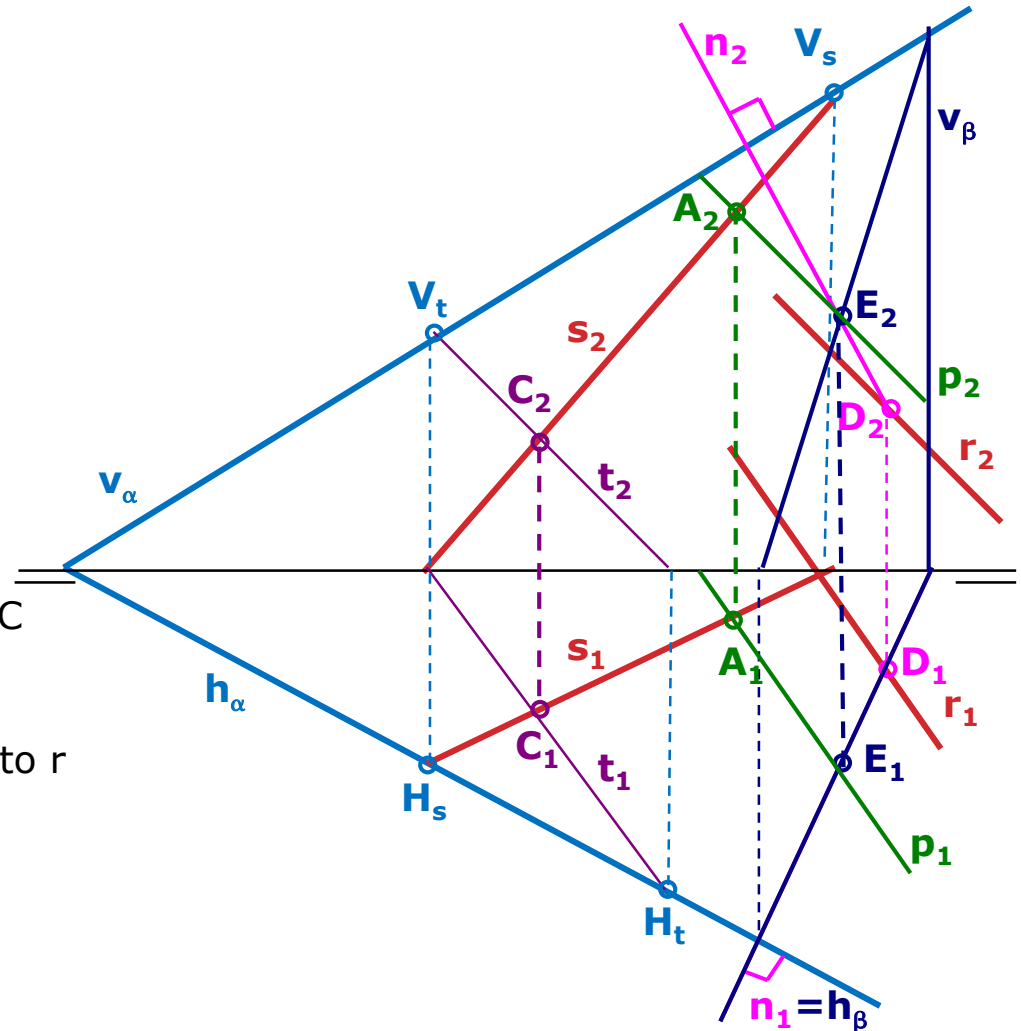

Distance between two crossing lines

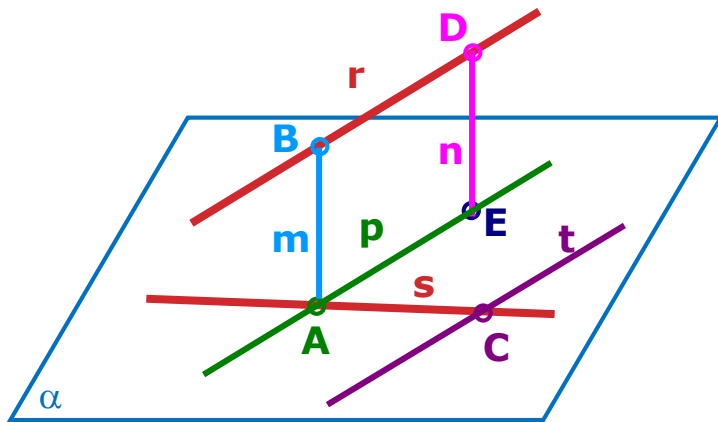

1. Draw line $t // r$ passing through a point C that belongs to s
2. Find plane α that contains s & t and $//$ to r
3. Draw $n \perp \alpha$ and cuts r at point D
4. Find $n \cap \alpha = E$
5. Draw a line $p // r$ and passes through E
6. Calculate $p \cap s = A$
7. Draw $m \perp \alpha$ through A and find $m \cap r = B$

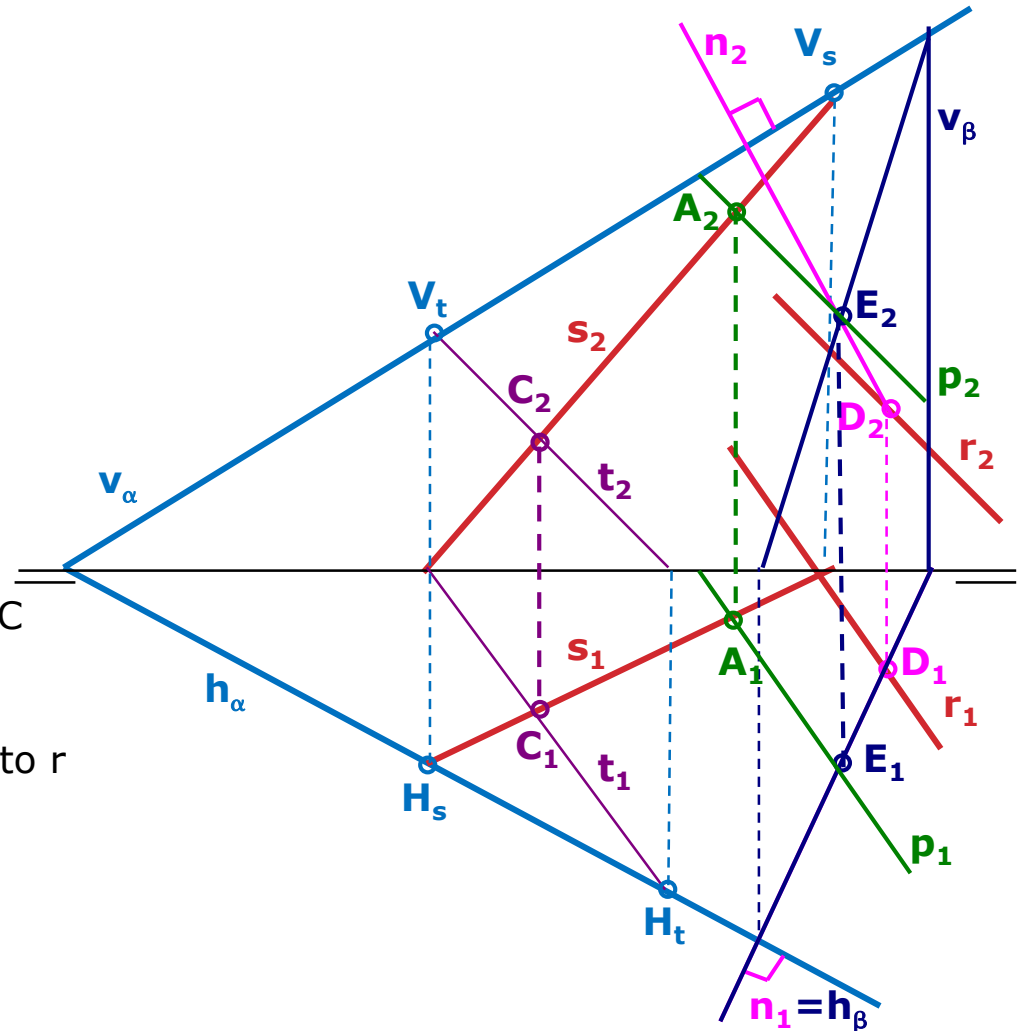

Distance between two crossing lines

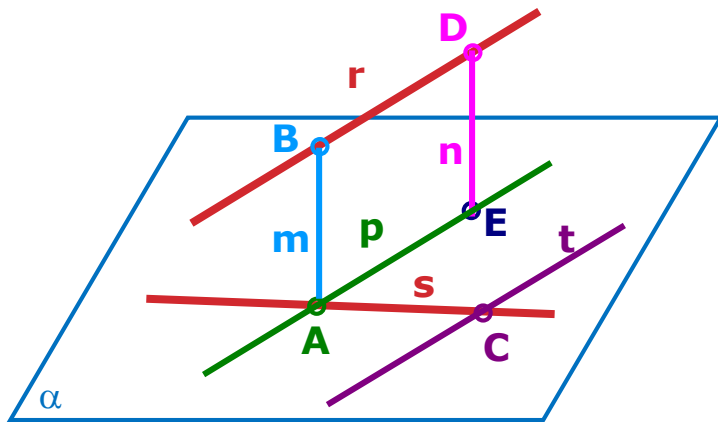

1. Draw line $t // r$ passing through a point C that belongs to s
2. Find plane α that contains s & t and $//$ to r
3. Draw $n \perp \alpha$ and cuts r at point D
4. Find $n \cap \alpha = E$
5. Draw a line $p // r$ and passes through E
6. Calculate $p \cap s = A$
7. Draw $m \perp \alpha$ through A and find $m \cap r = B$

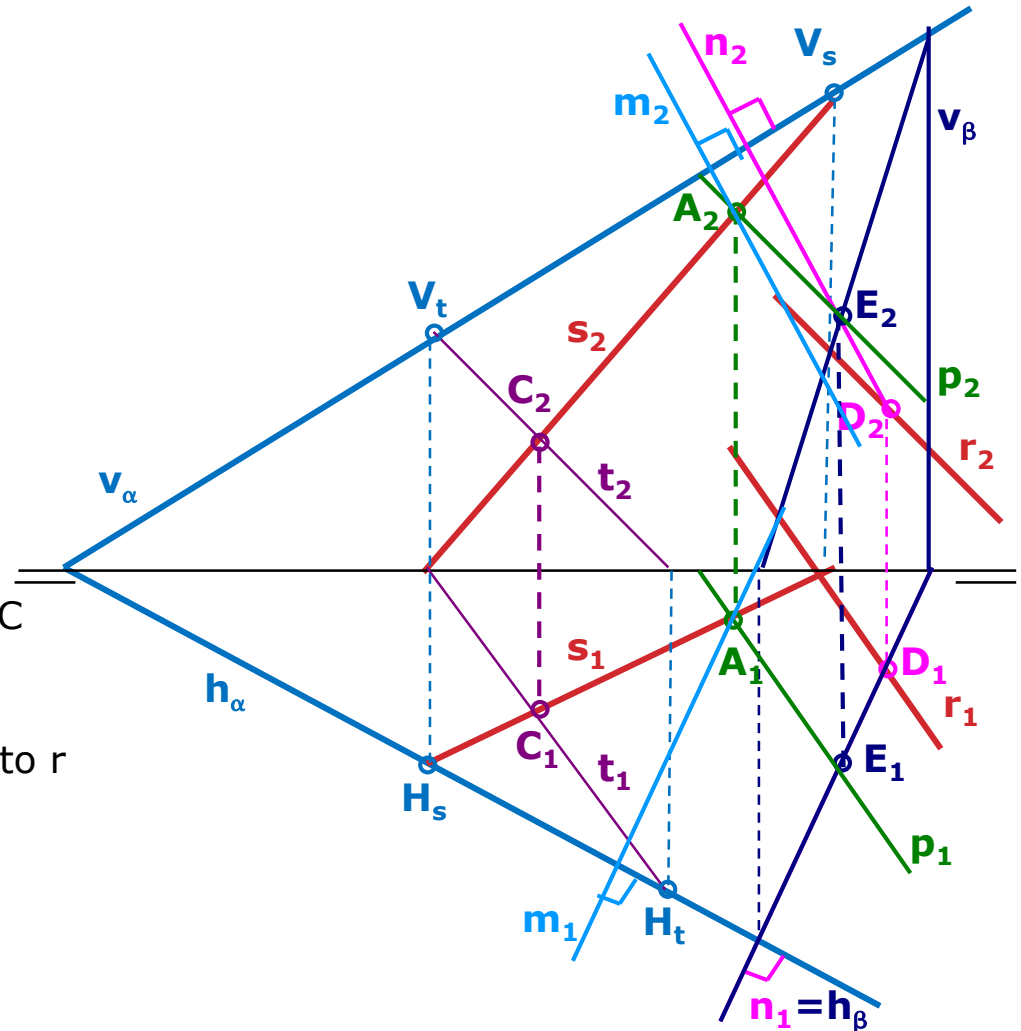

Distance between two crossing lines

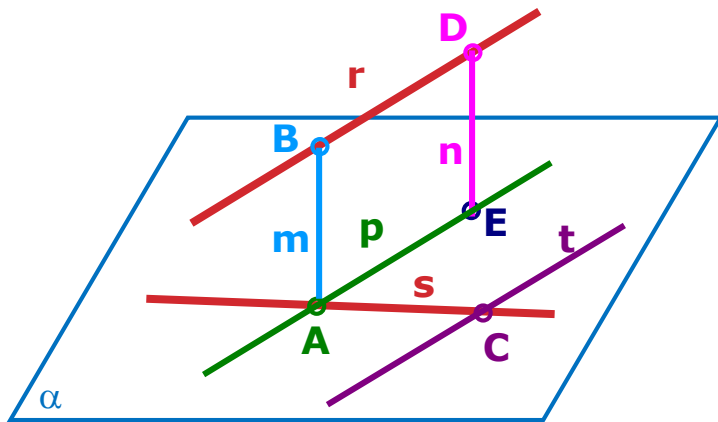

1. Draw line $t // r$ passing through a point C that belongs to s
2. Find plane α that contains s & t and $//$ to r
3. Draw $n \perp \alpha$ and cuts r at point D
4. Find $n \cap \alpha = E$
5. Draw a line $p // r$ and passes through E
6. Calculate $p \cap s = A$
7. Draw $m \perp \alpha$ through A and find $m \cap r = B$

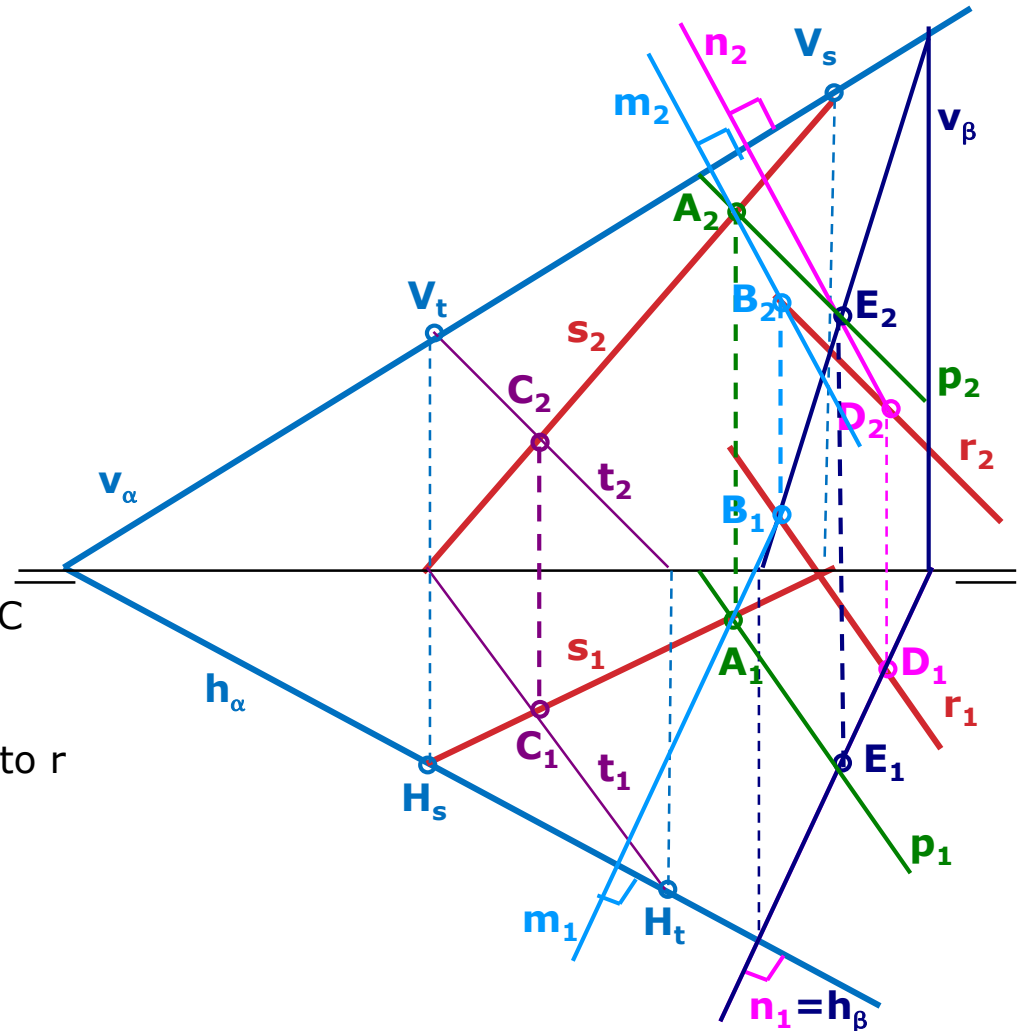

Distance between two crossing lines

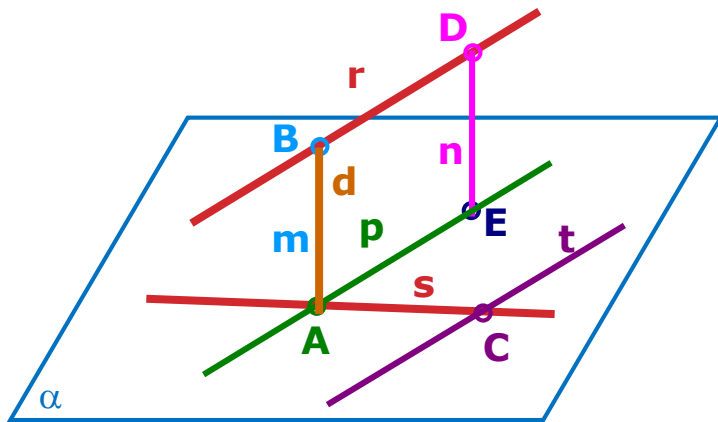

1. Draw line $t // r$ passing through a point C that belongs to s
2. Find plane α that contains s & t and $//$ to r
3. Draw $n \perp \alpha$ and cuts r at point D
4. Find $n \cap \alpha = E$
5. Draw a line $p // r$ and passes through E
6. Calculate $p \cap s = A$
7. Draw $m \perp \alpha$ through A and find $m \cap r = B$

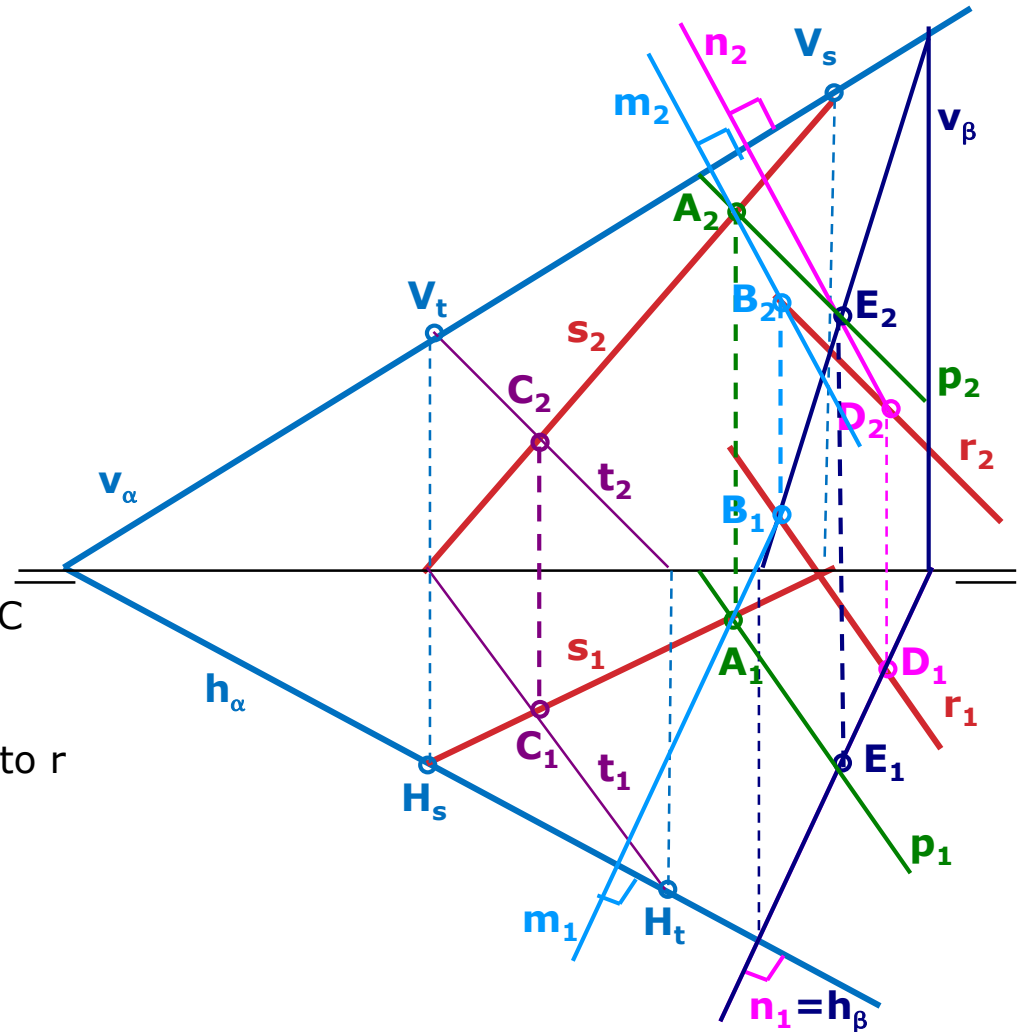

Distance between two crossing lines

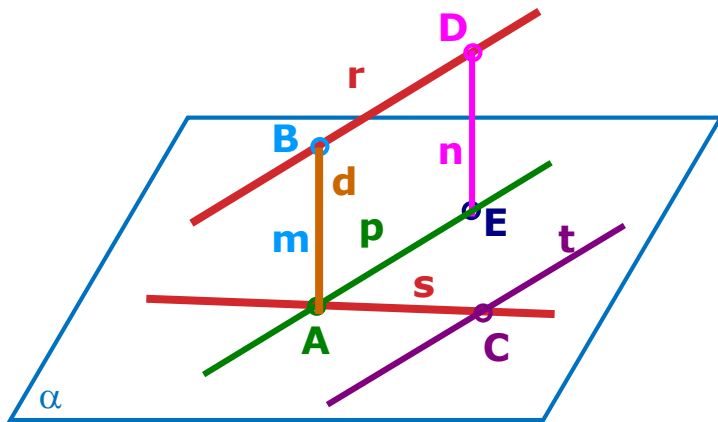

1. Draw line $t // r$ passing through a point C that belongs to s
2. Find plane α that contains s & t and $//$ to r
3. Draw $n \perp \alpha$ and cuts r at point D
4. Find $n \cap \alpha = E$
5. Draw a line $p // r$ and passes through E
6. Calculate $p \cap s = A$
7. Draw $m \perp \alpha$ through A and find $m \cap r = B$

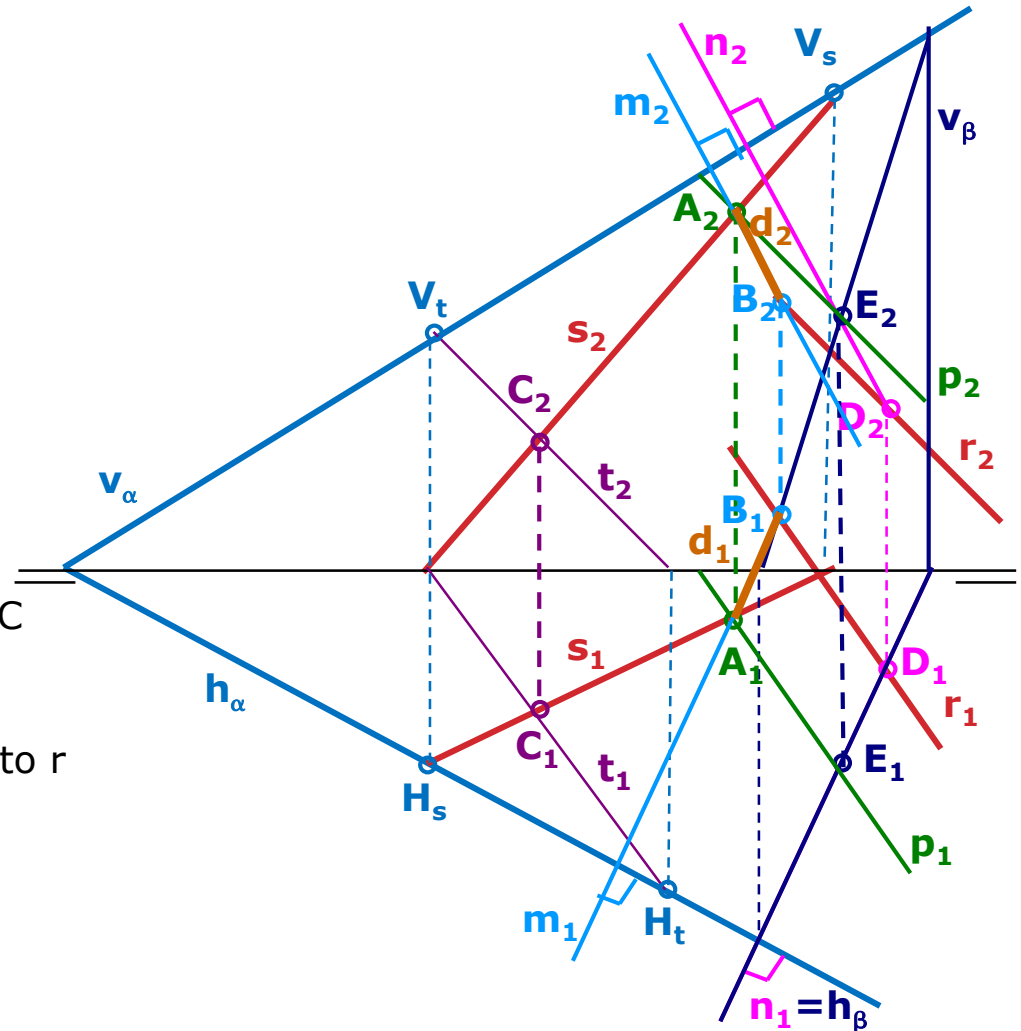

Distance between two crossing lines I

□ First method

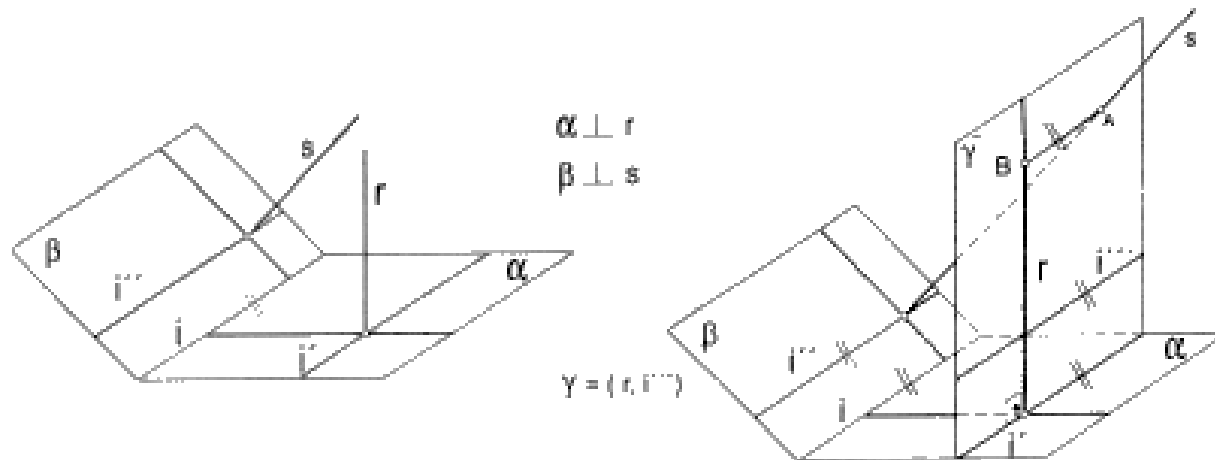

1. Draw plane $\alpha \perp r$ and plane $\beta \perp s$.
2. Find the intersection of α and $\beta \Rightarrow$ line i .
3. Find plane γ defined by line r and line i' .
4. Find the traces of line s with plane $\gamma \Rightarrow$ point A .
5. Draw line $// i'$ that passes through A .
6. Find intersection with $r \Rightarrow$ point B .

Distance between two crossing lines II

□ Second method

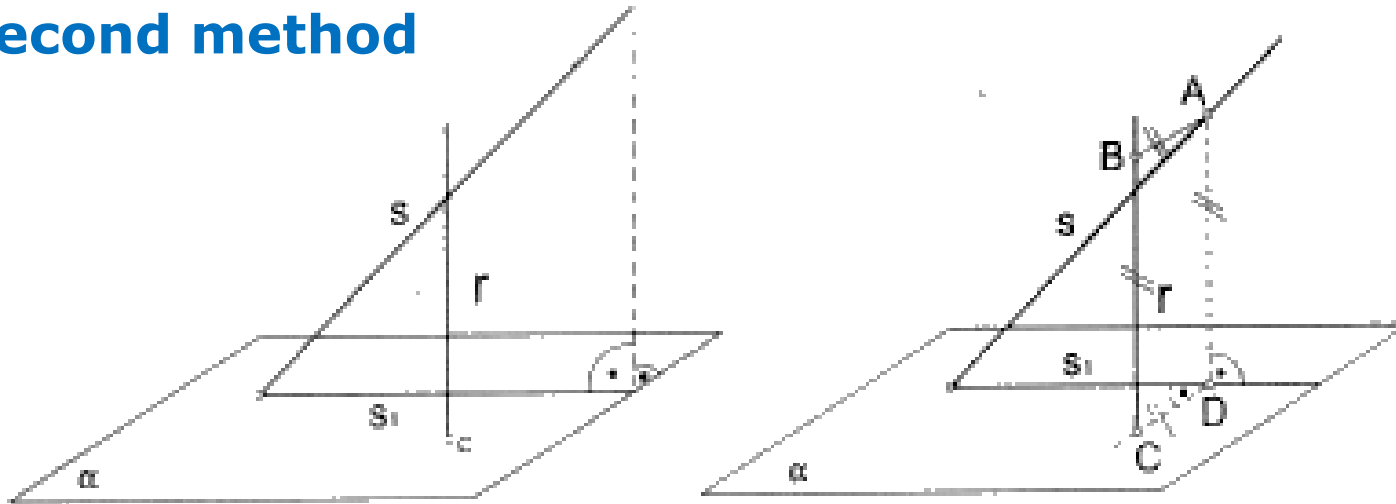

$\alpha \perp r$

1. Draw plane $\alpha \perp$ to line r and passes through point C .
2. Find orthogonal projection s_1 of the line s over plane α .
3. Draw a line \perp to s_1 and passes through C .
4. Find point D (intersection of the line with s_1).
5. Draw a line $//$ to line r and passes through D .
6. Find the point of intersection A .

Distance between two crossing lines III

□ Third method

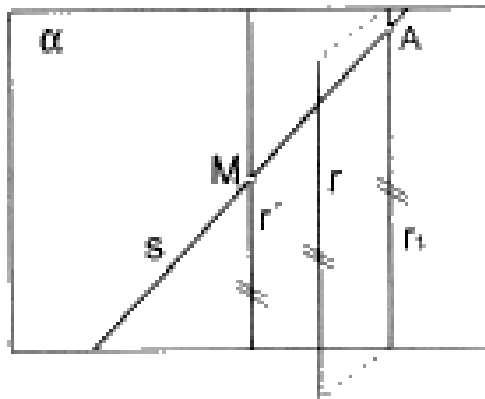

$$\alpha = [s, r']$$

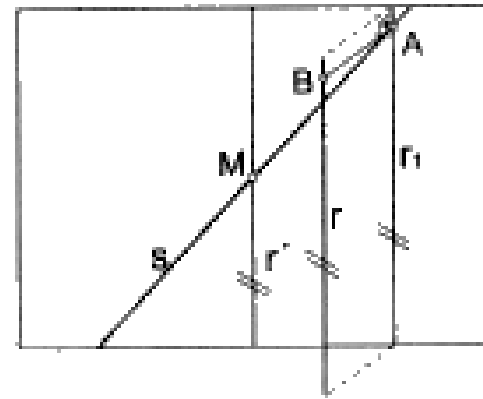

1. Draw line $r' //$ to line r and passes through a point on line s .
2. Find plane α that contains line r' and line s .
3. Find the orthogonal projection of r over the plane $\alpha \Rightarrow r_1$.
4. Find the intersection of line r_1 with line $s \Rightarrow A$.
5. Find the line \perp to plane α that passes through point A .
6. Find the intersection with line $r \Rightarrow B$.

Angles of a line with respect to the projection planes I

- By means of the fold line method

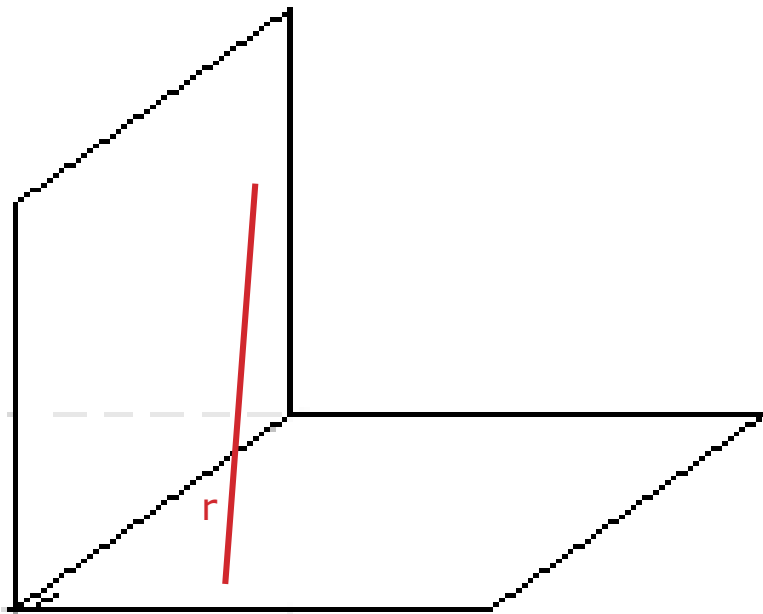

Angles of a line with respect to the projection planes I

- By means of the fold line method

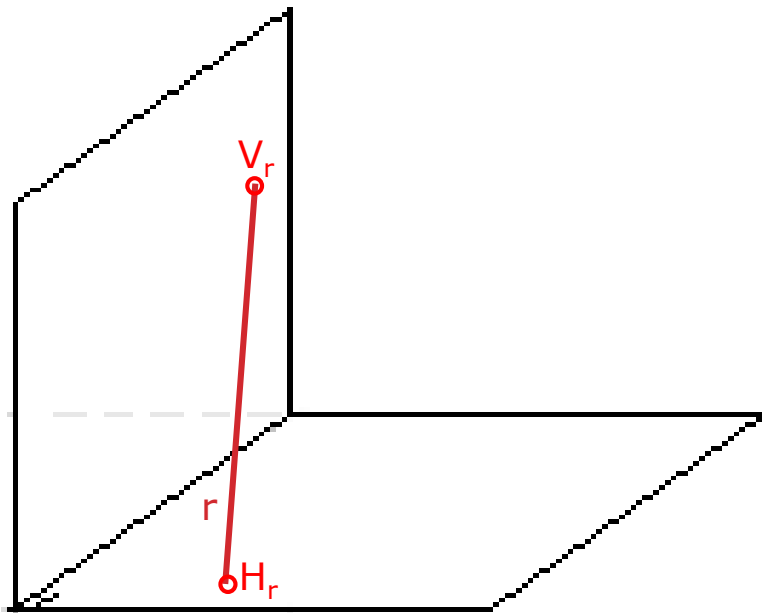

Angles of a line with respect to the projection planes I

- By means of the fold line method

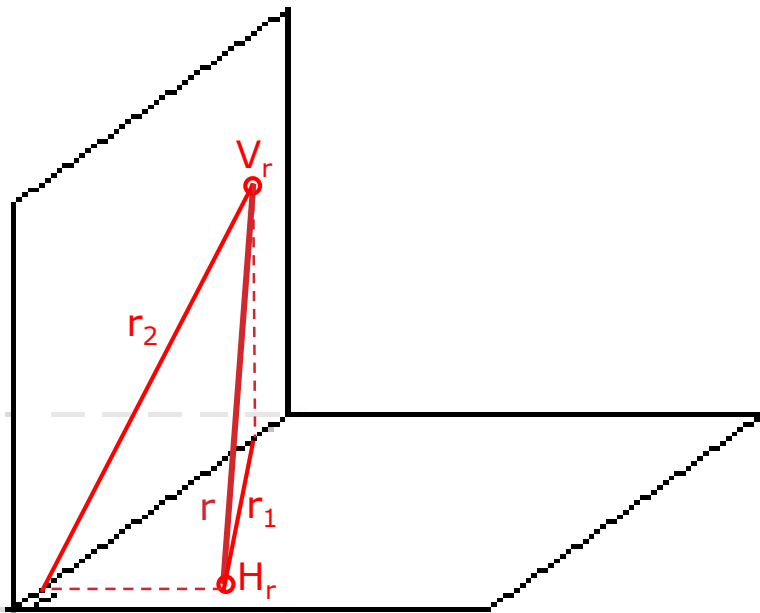

Angles of a line with respect to the projection planes I

- By means of the fold line method

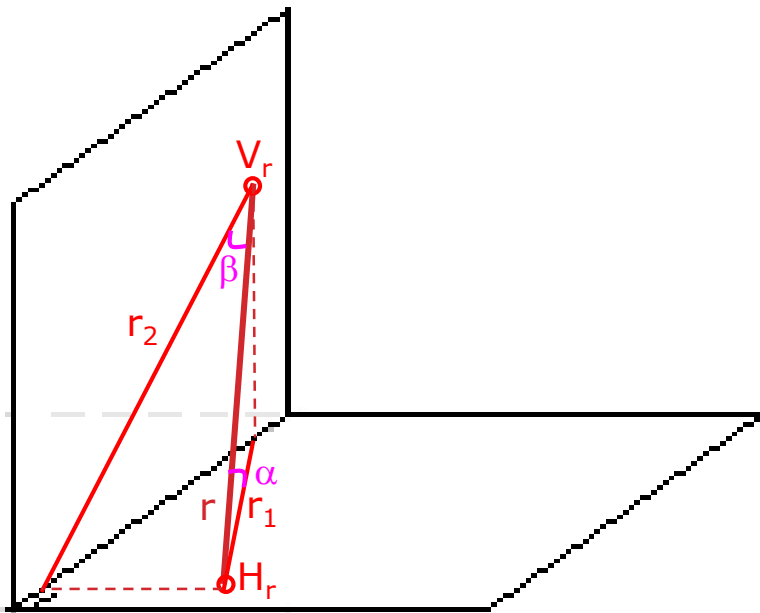

Angles of a line with respect to the projection planes I

- By means of the fold line method

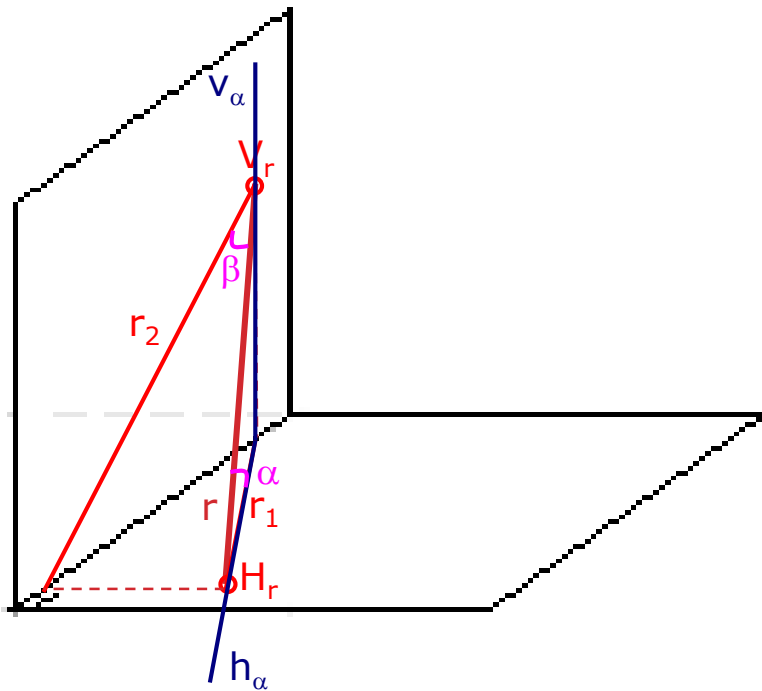

Angles of a line with respect to the projection planes I

- By means of the fold line method

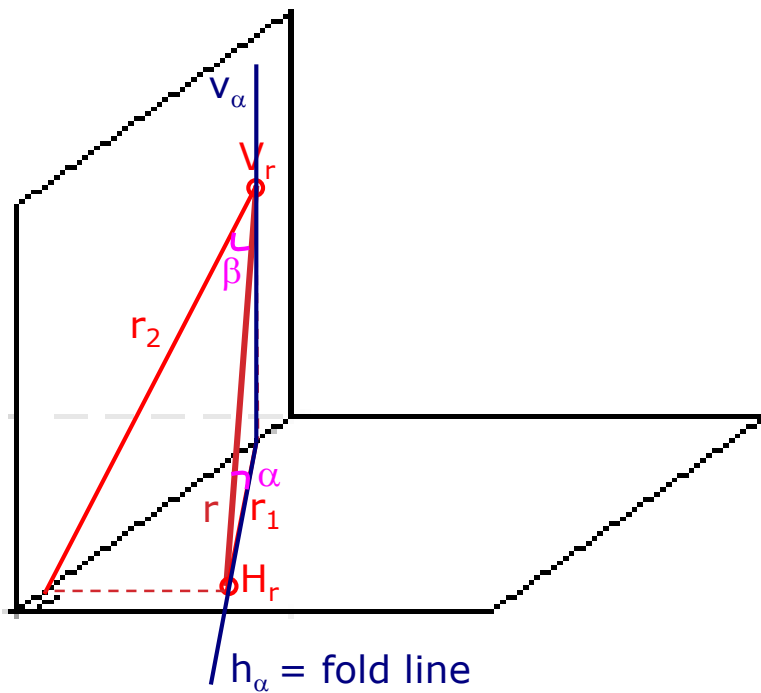

Angles of a line with respect to the projection planes I

- By means of the fold line method

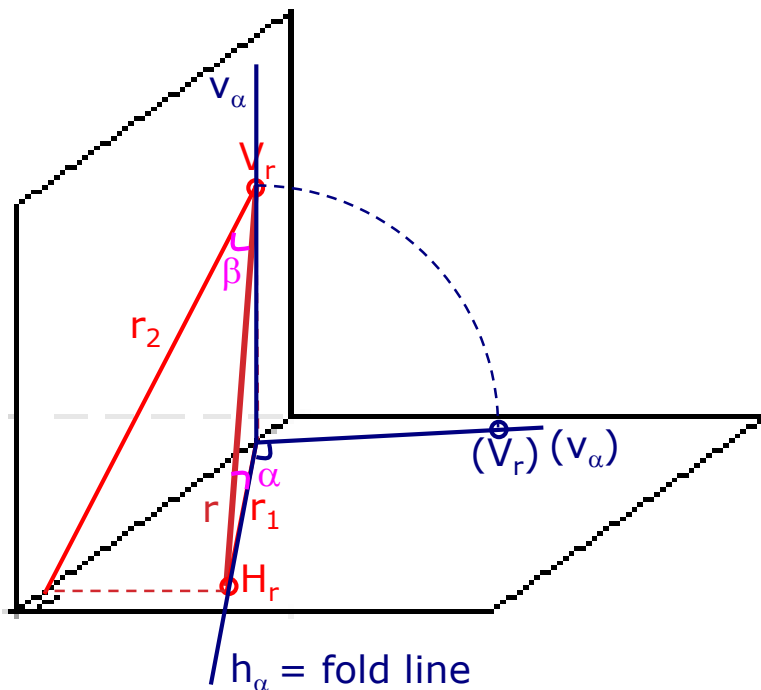

Angles of a line with respect to the projection planes I

- By means of the fold line method

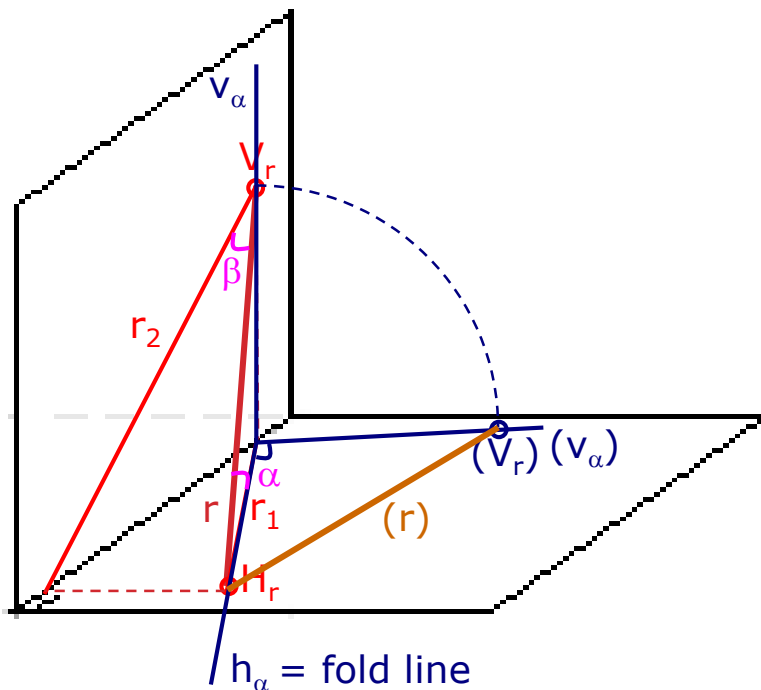

Angles of a line with respect to the projection planes I

- By means of the fold line method

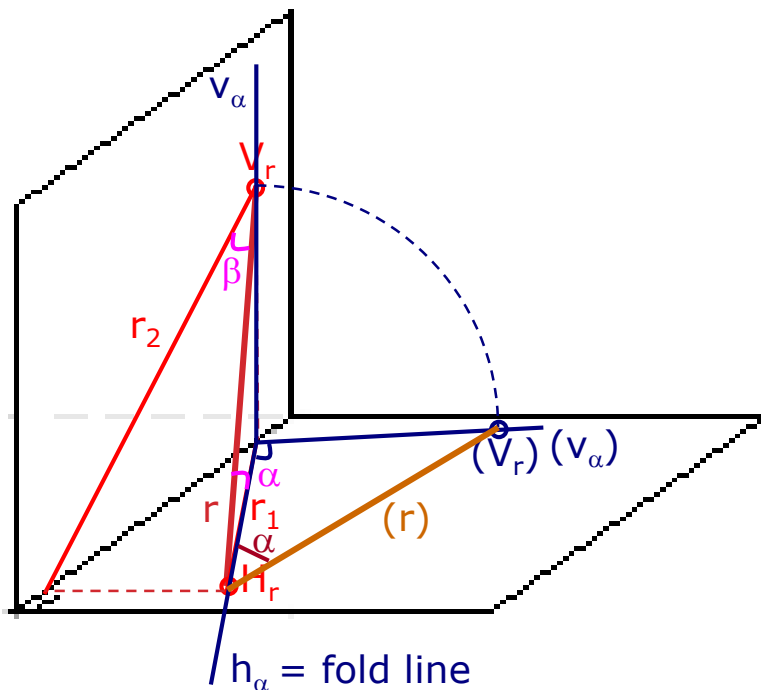

Angles of a line with respect to the projection planes I

- By means of the fold line method

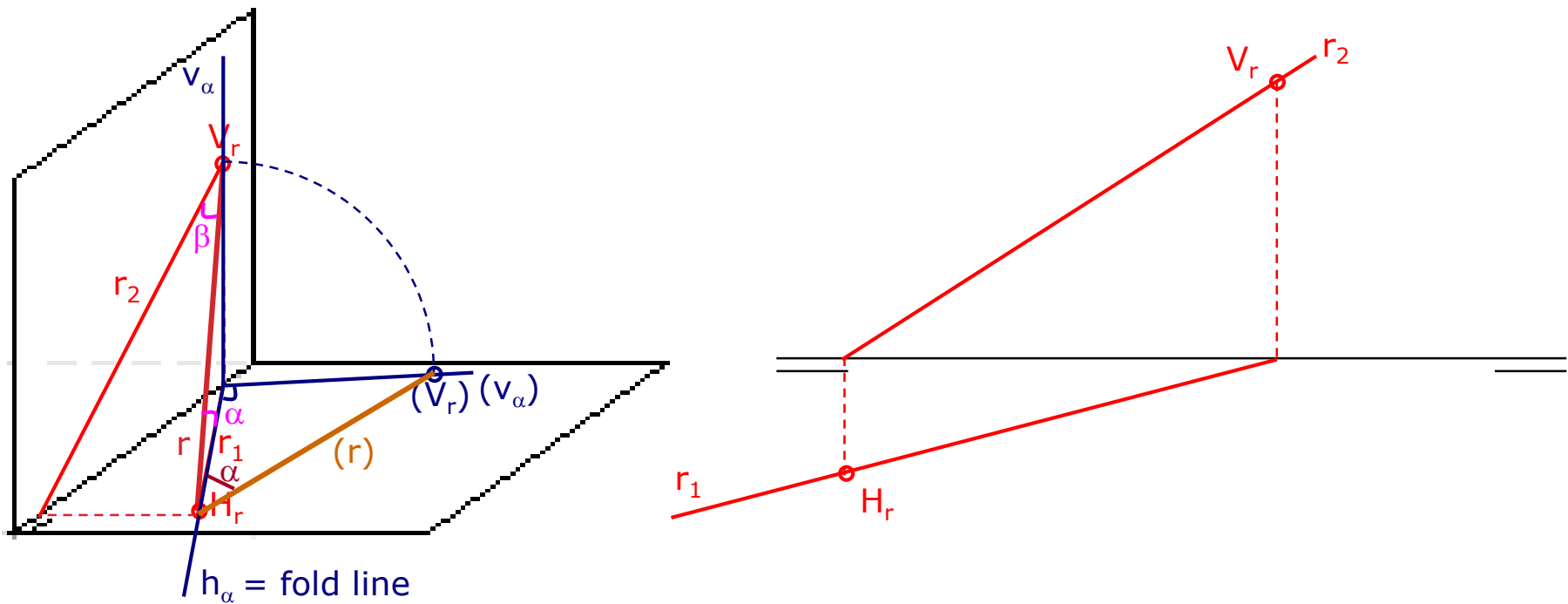

Angles of a line with respect to the projection planes I

- By means of the fold line method

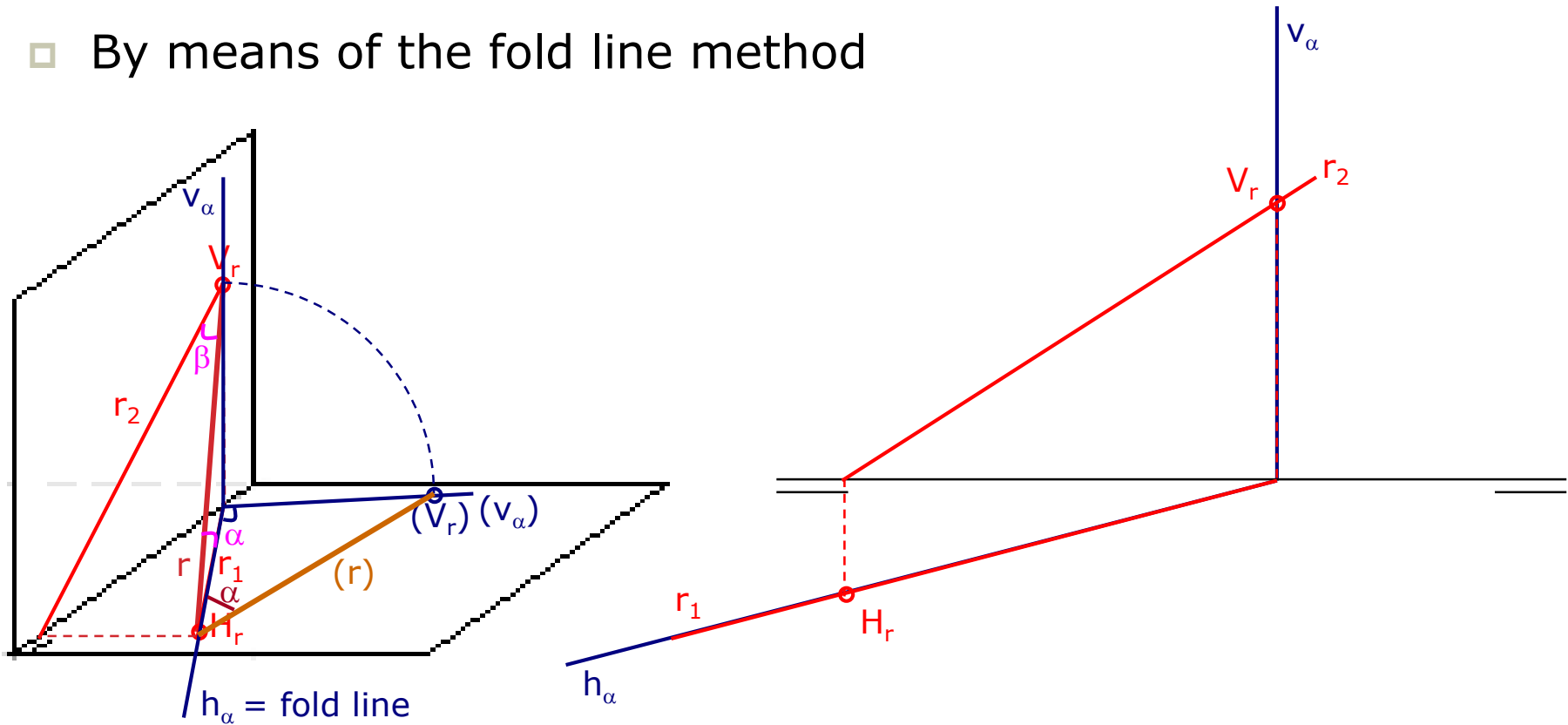

Angles of a line with respect to the projection planes I

- By means of the fold line method

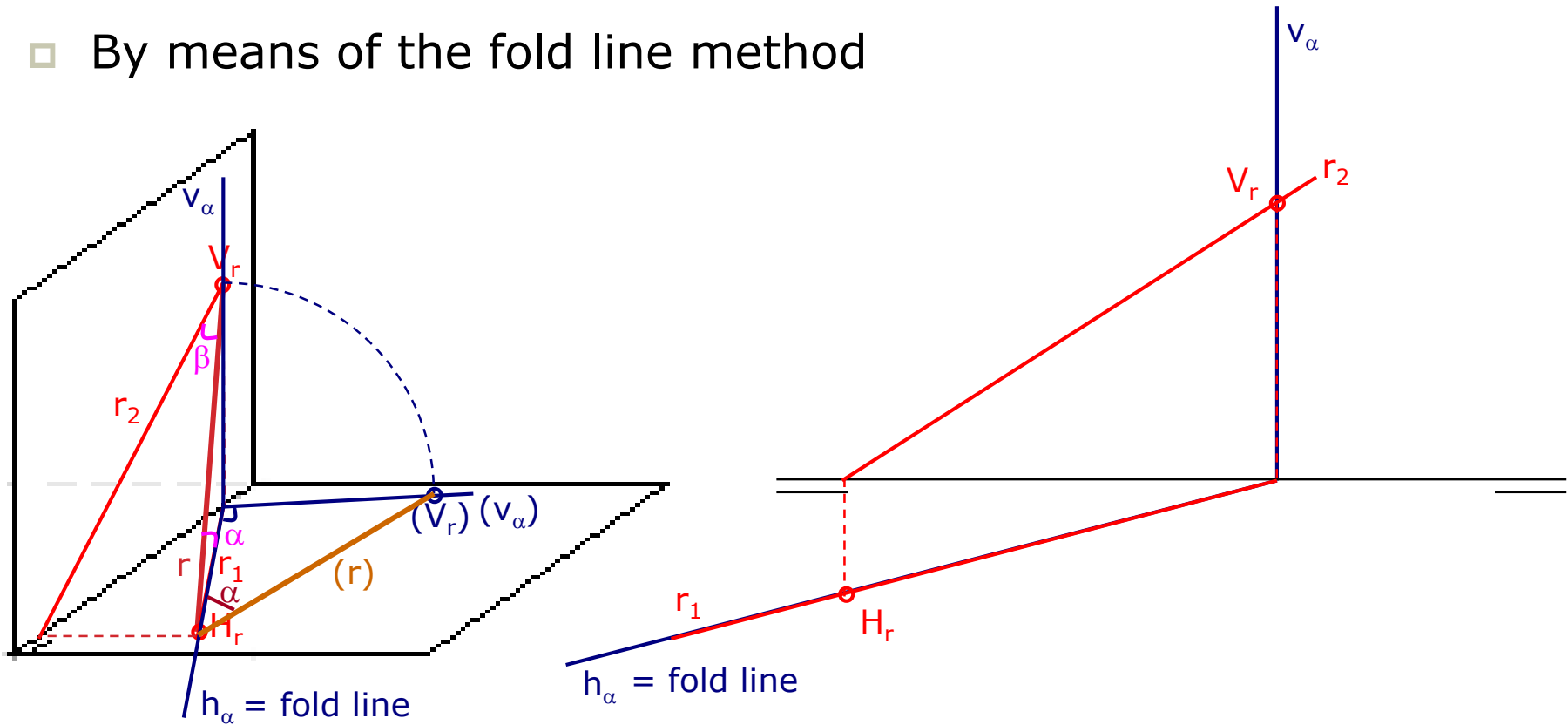

Angles of a line with respect to the projection planes I

- By means of the fold line method

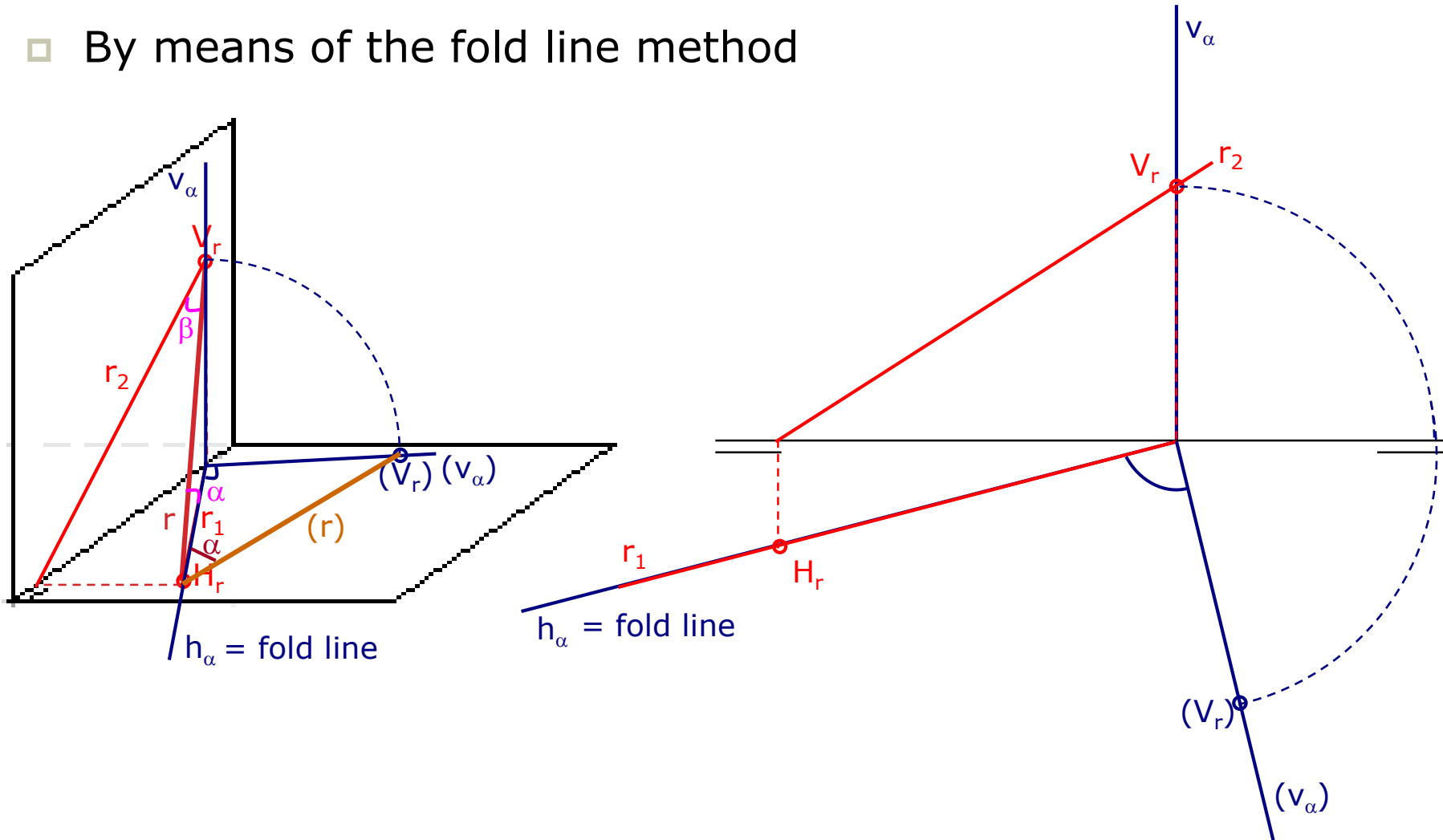

Angles of a line with respect to the projection planes I

- By means of the fold line method

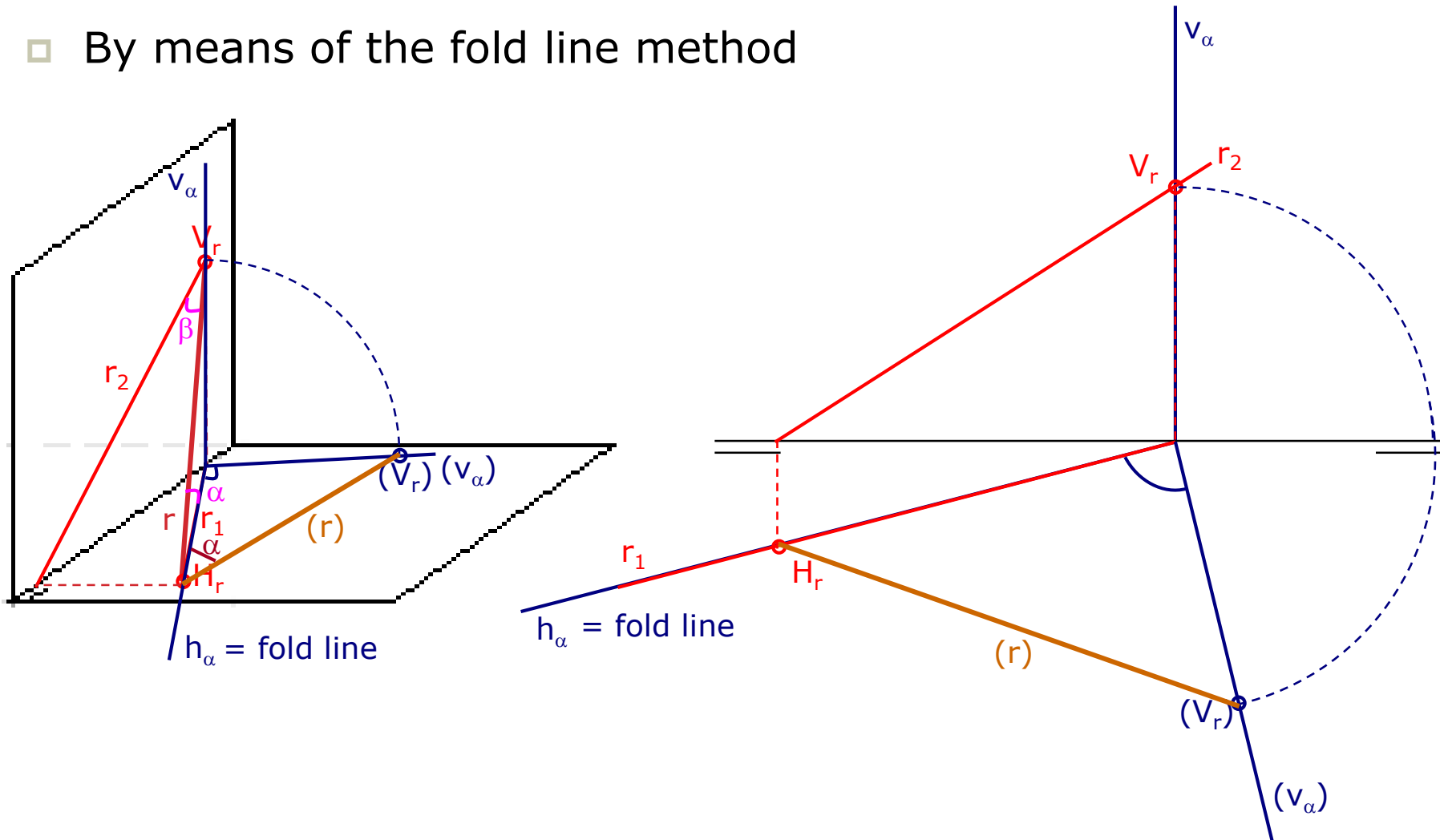

Angles of a line with respect to the projection planes I

- By means of the fold line method

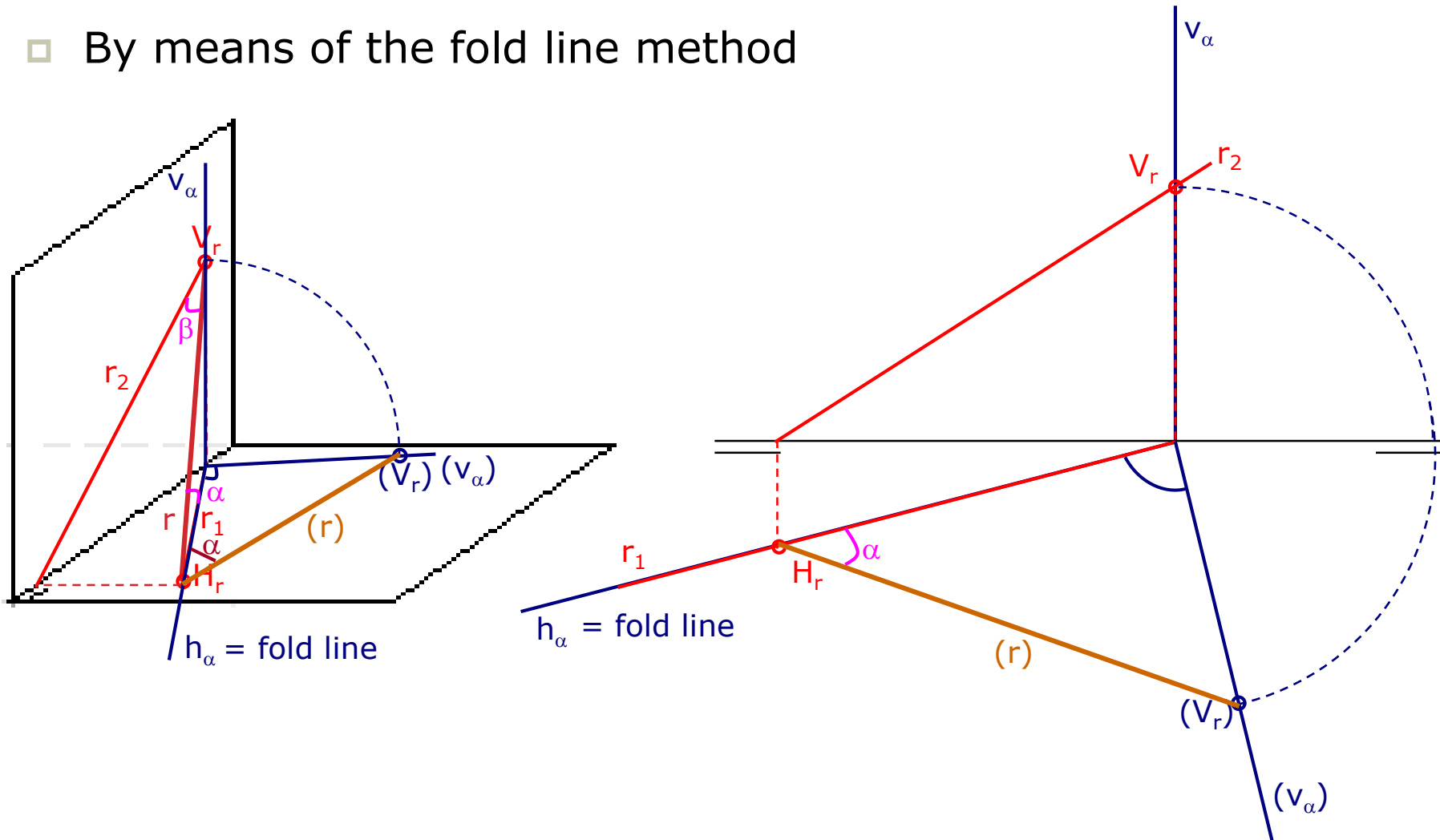

Angles of a line with respect to the projection planes I

- By means of the fold line method

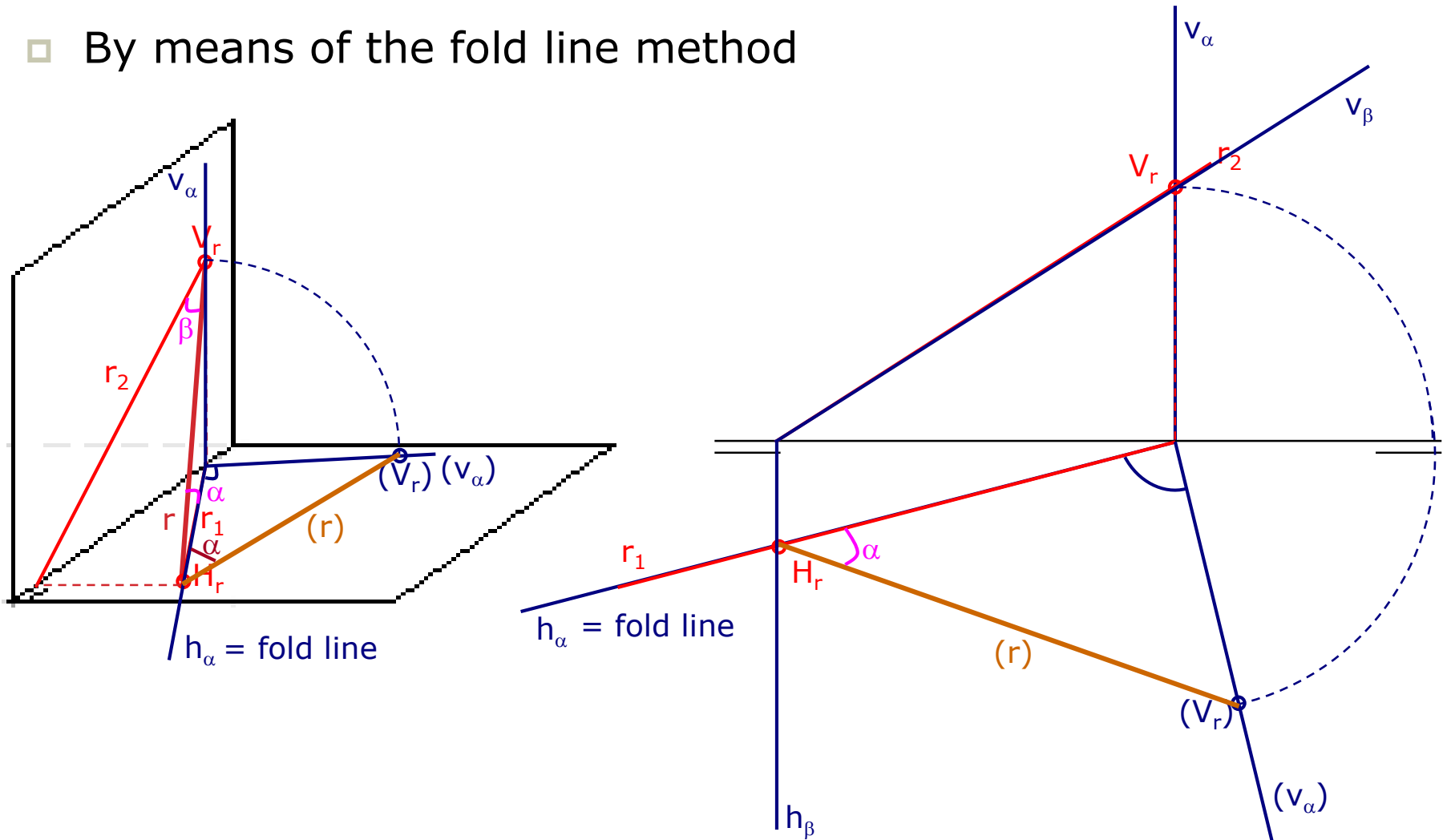

Angles of a line with respect to the projection planes I

- By means of the fold line method

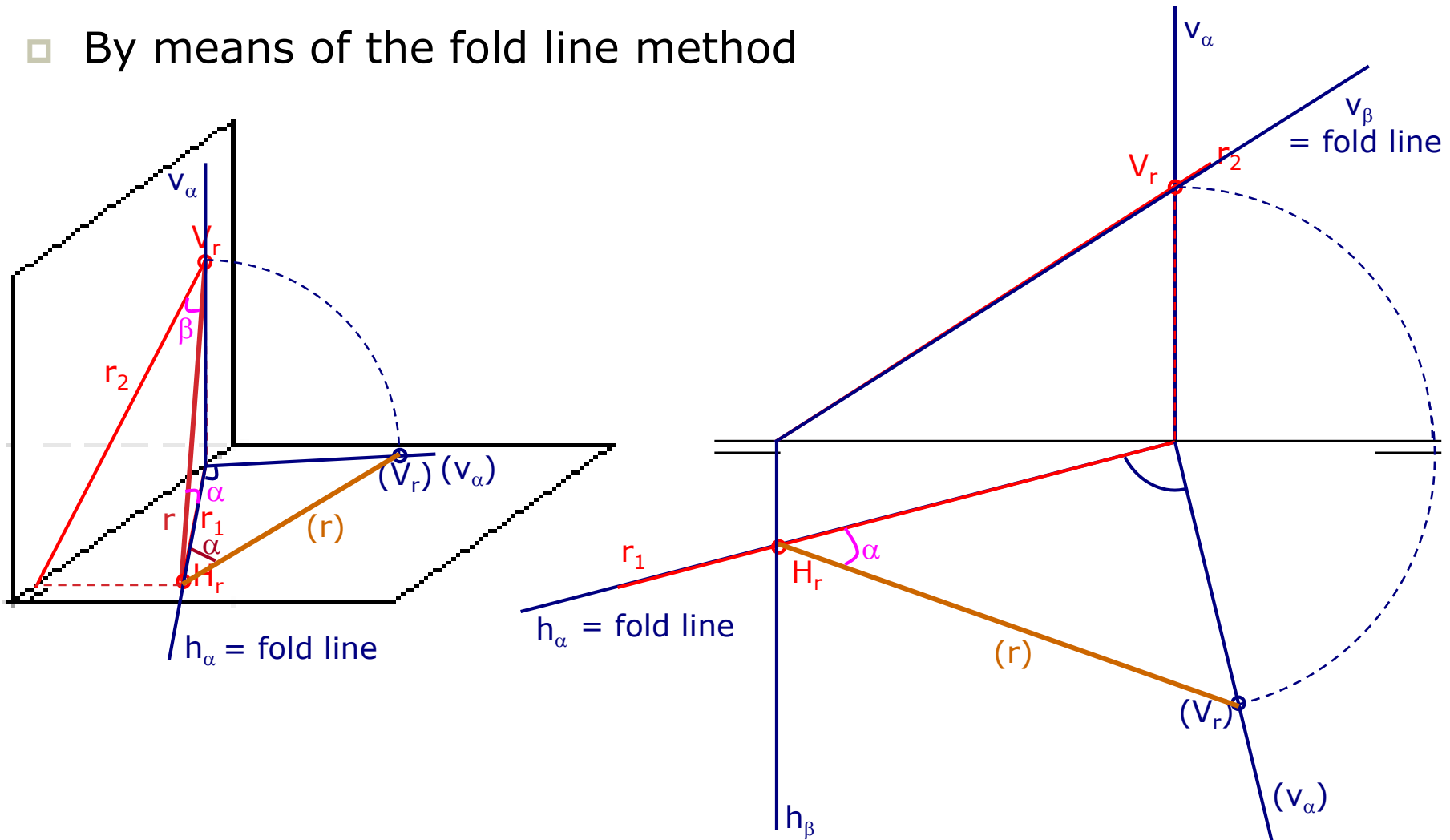

Angles of a line with respect to the projection planes I

- By means of the fold line method

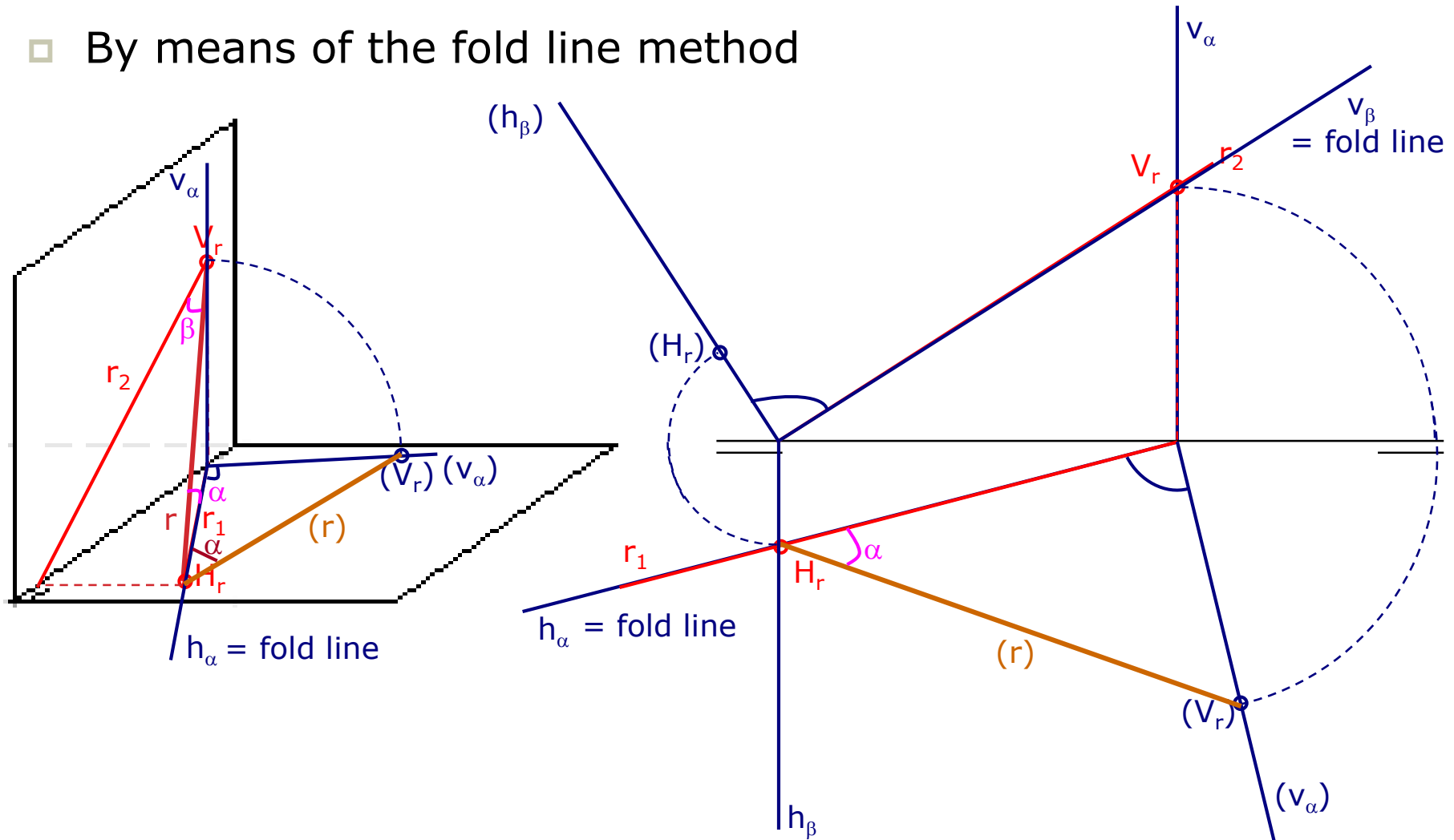

Angles of a line with respect to the projection planes I

- By means of the fold line method

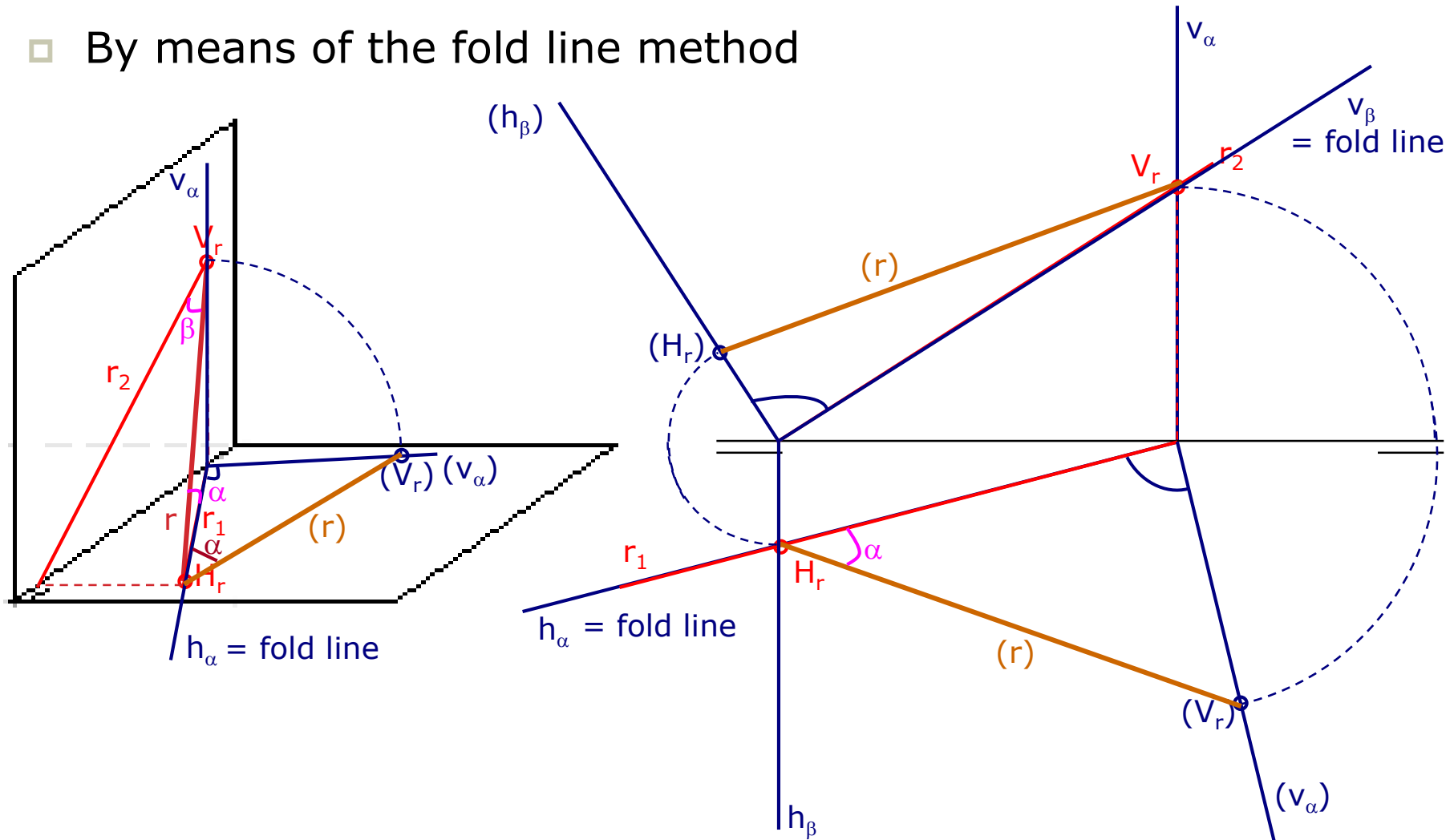

Angles of a line with respect to the projection planes I

- By means of the fold line method

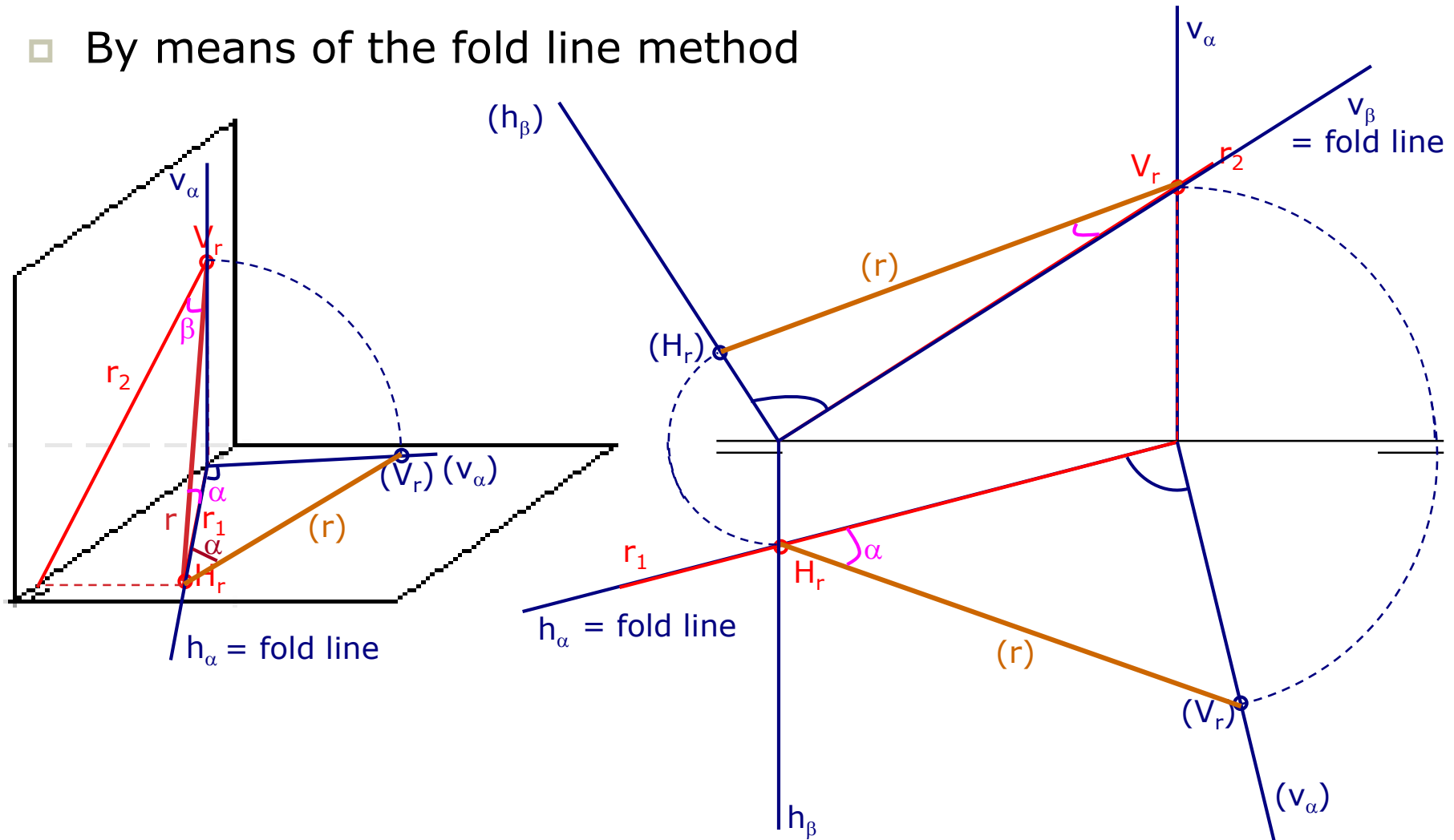

Angles of a line with respect to the projection planes I

- By means of the fold line method

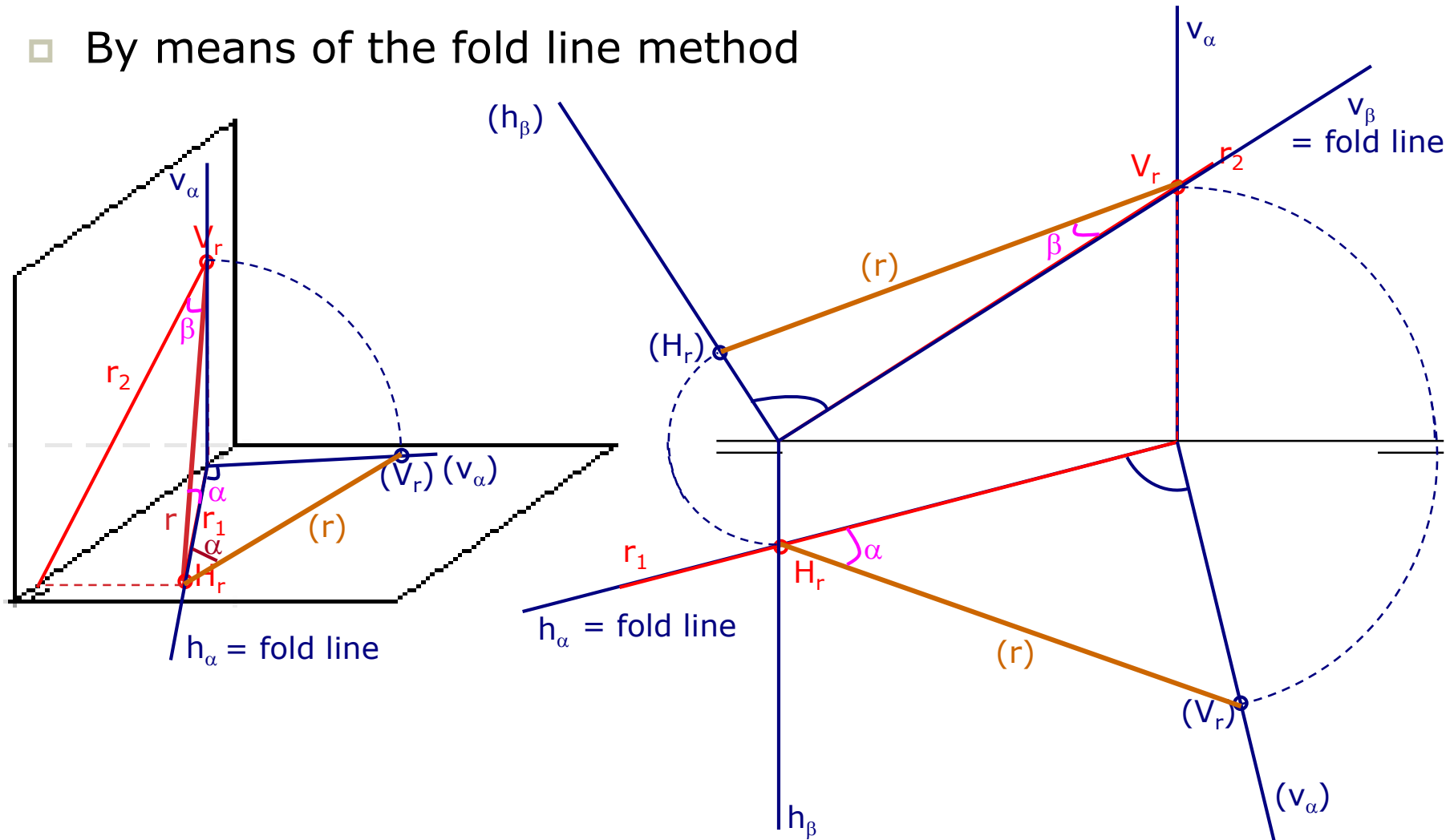

Angles of a line with respect to the projection planes I

- By means of the fold line method

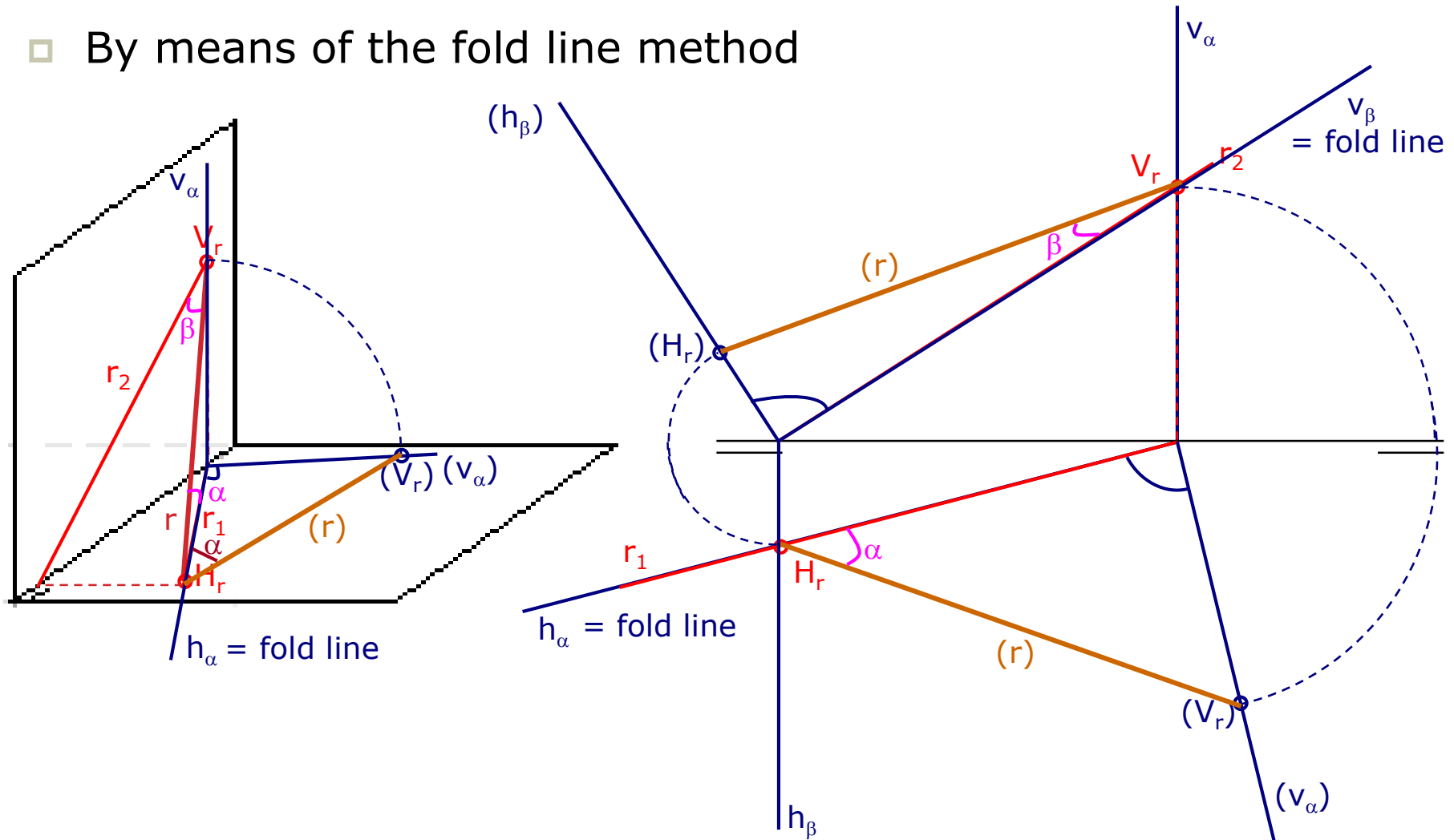

Angles of a line with respect to the projection planes II

- By means of revolution method

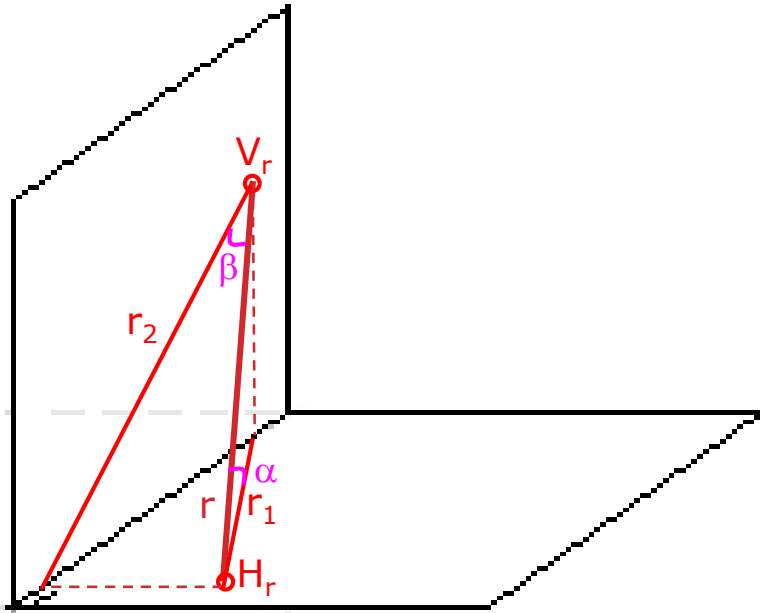

Angles of a line with respect to the projection planes II

- By means of revolution method

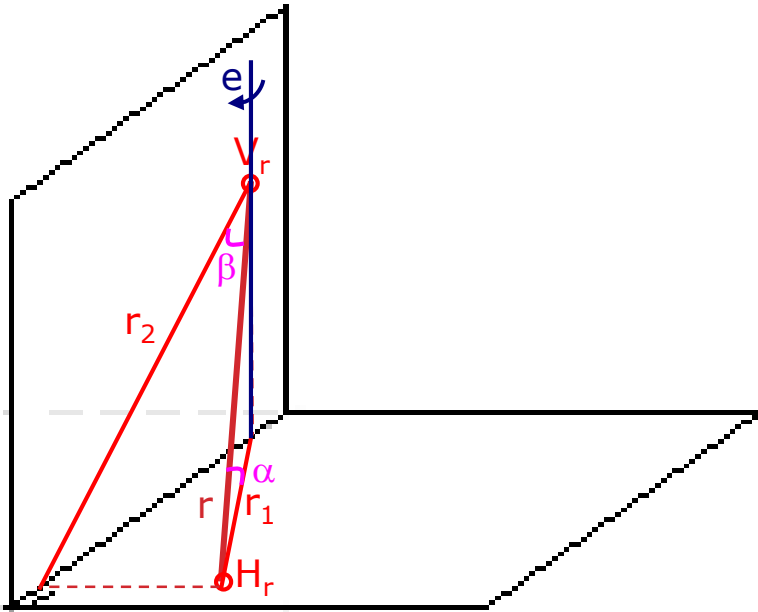

Angles of a line with respect to the projection planes II

- By means of revolution method

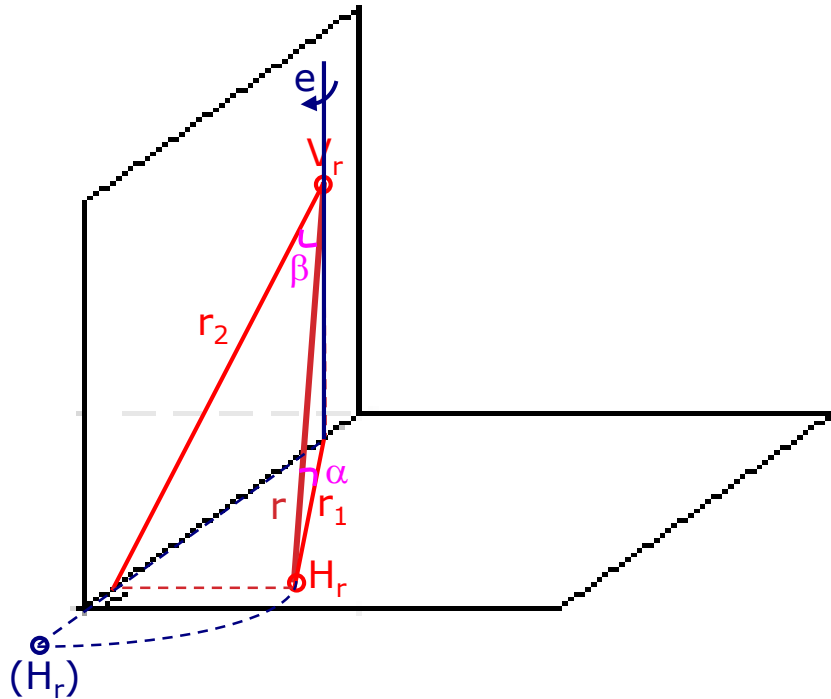

Angles of a line with respect to the projection planes II

- By means of revolution method

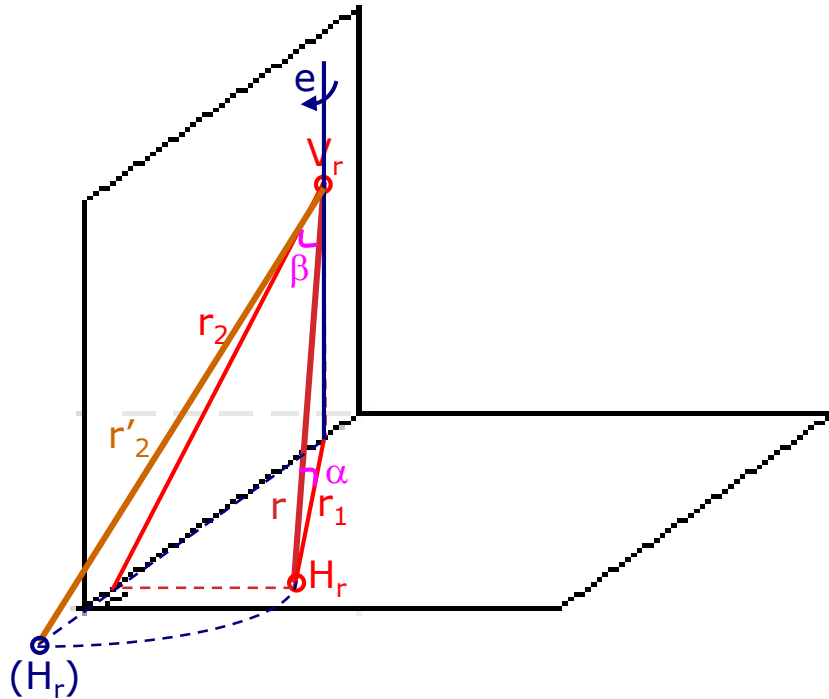

Angles of a line with respect to the projection planes II

- By means of revolution method

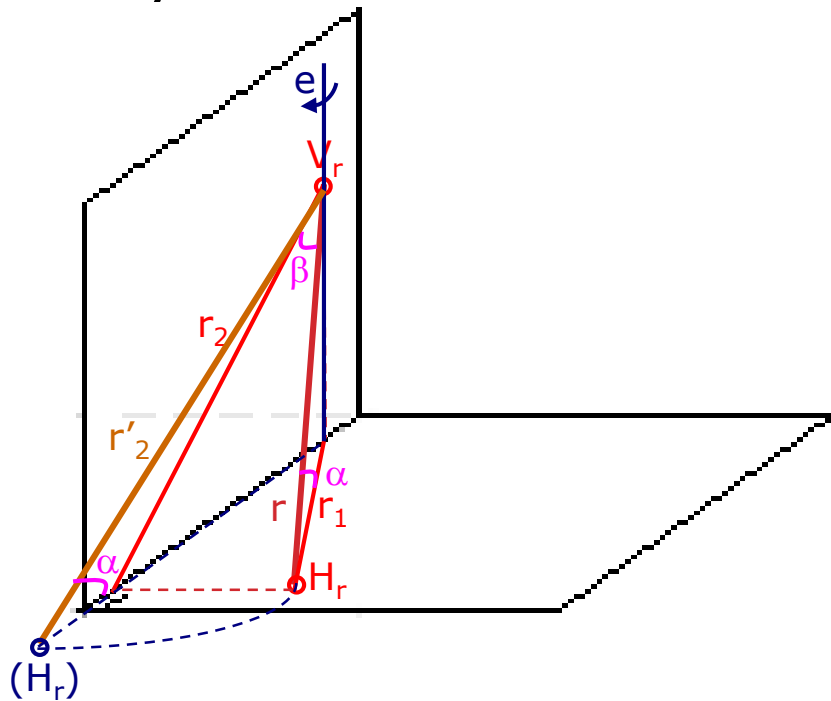

Angles of a line with respect to the projection planes II

- By means of revolution method

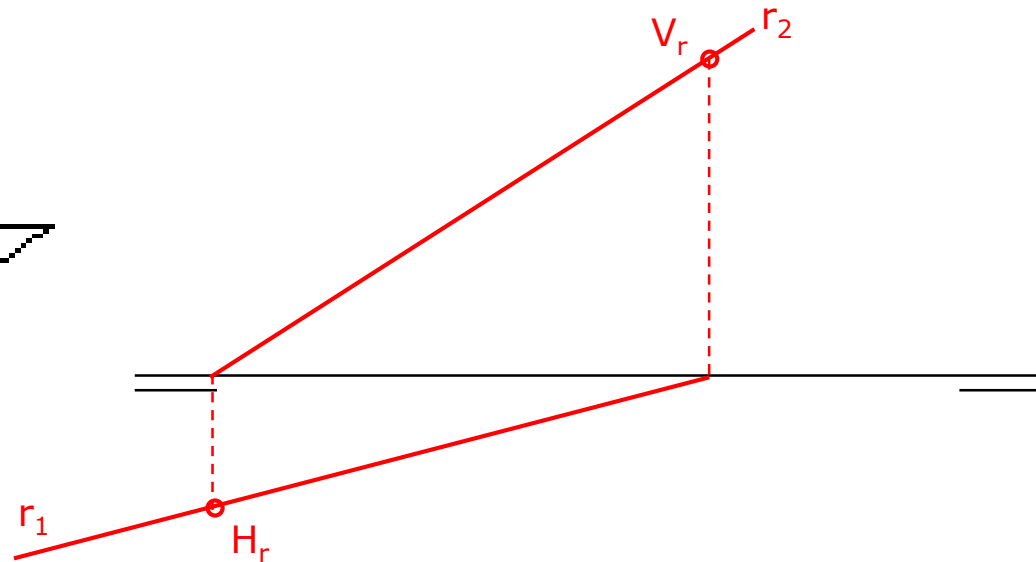
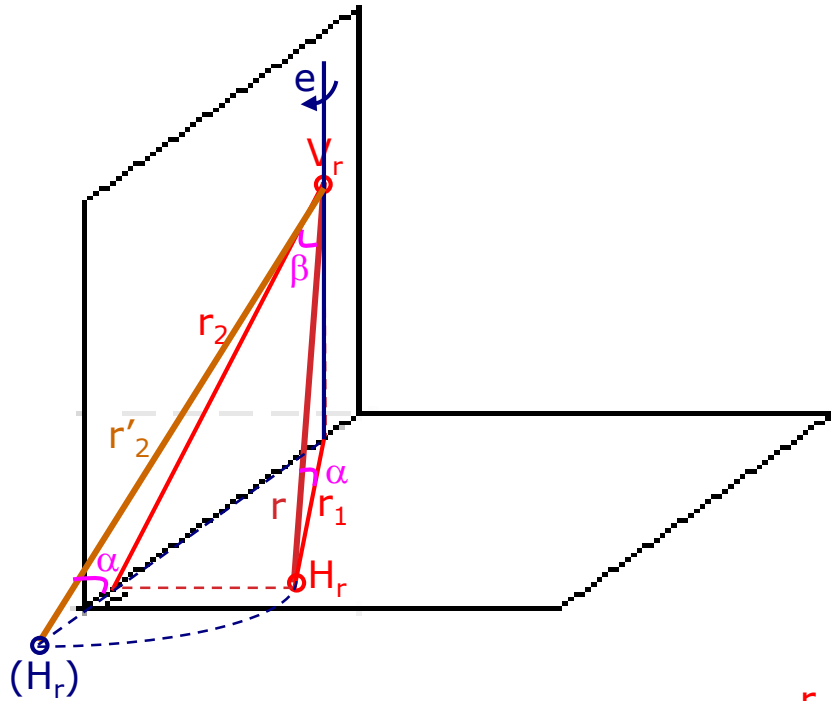

Angles of a line with respect to the projection planes II

- By means of revolution method

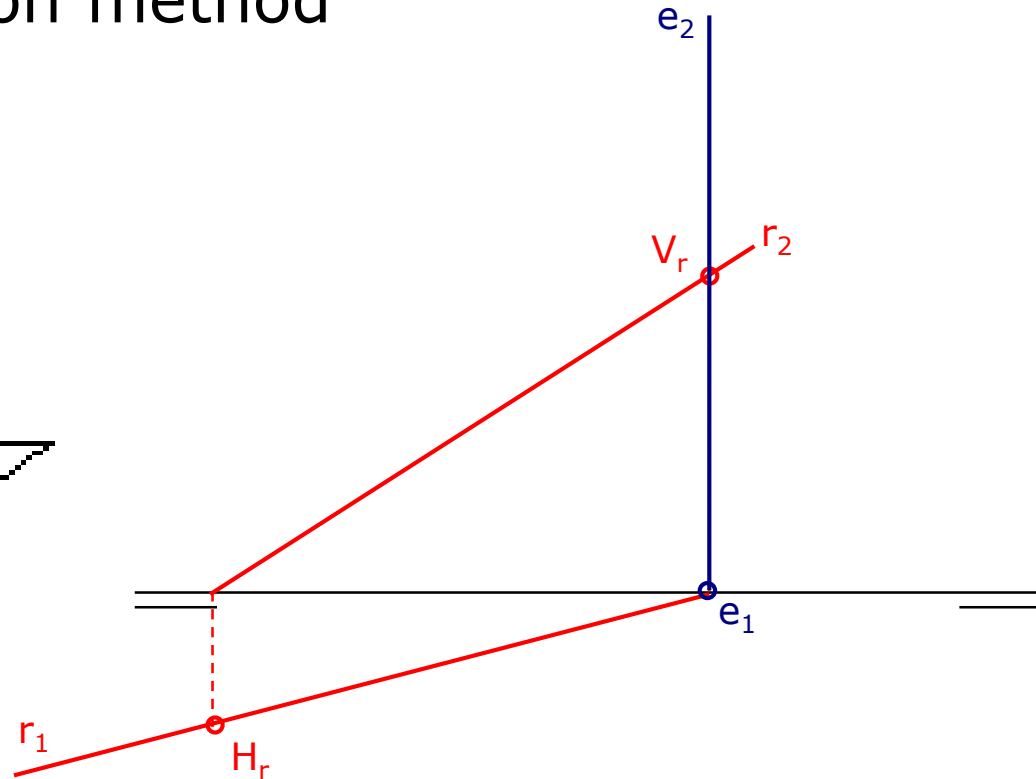
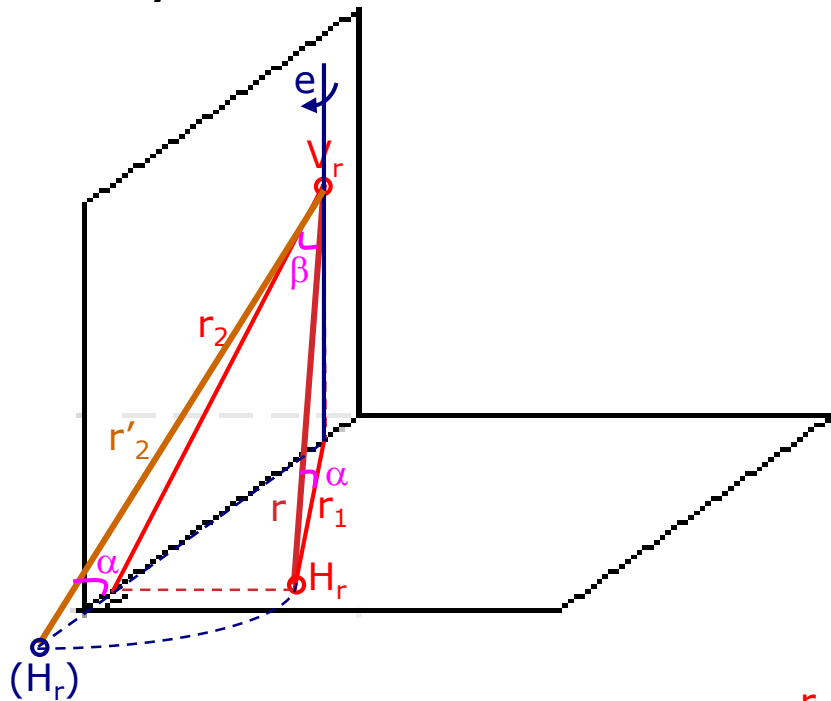

Angles of a line with respect to the projection planes II

- By means of revolution method

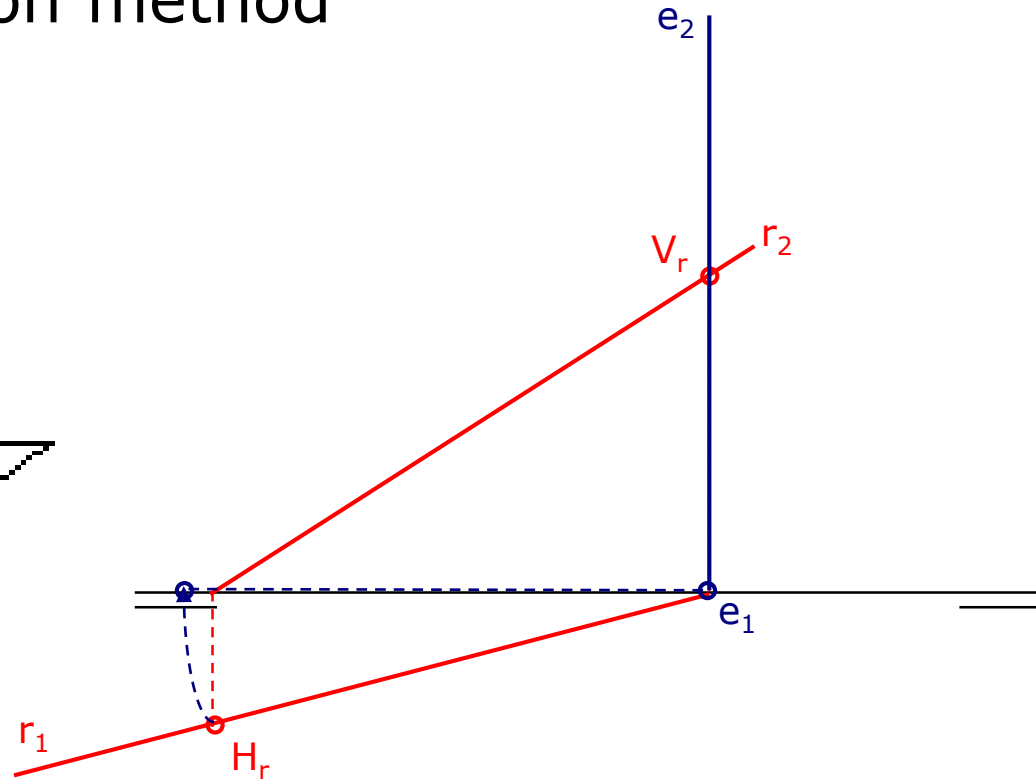
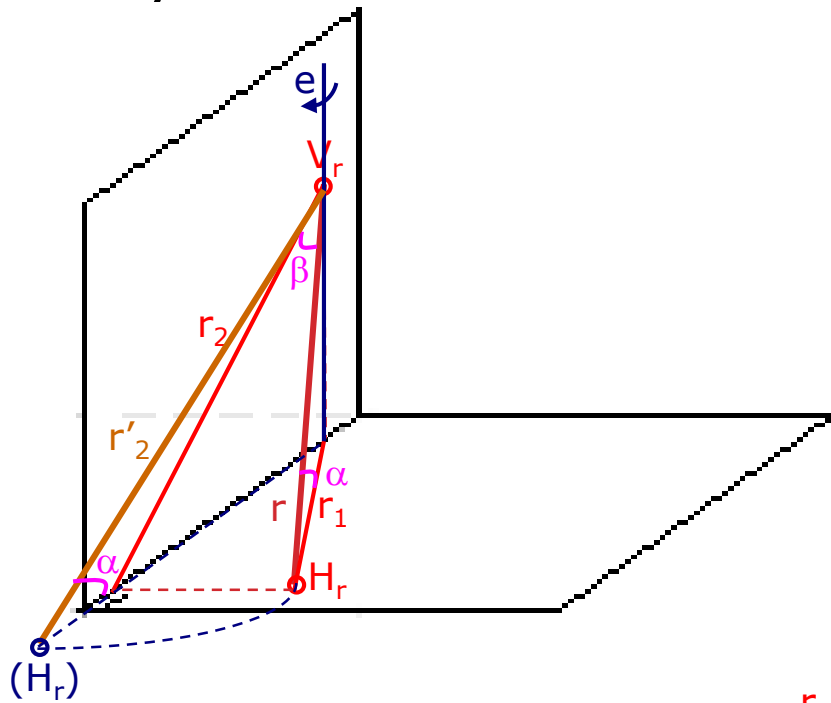

Angles of a line with respect to the projection planes II

- By means of revolution method

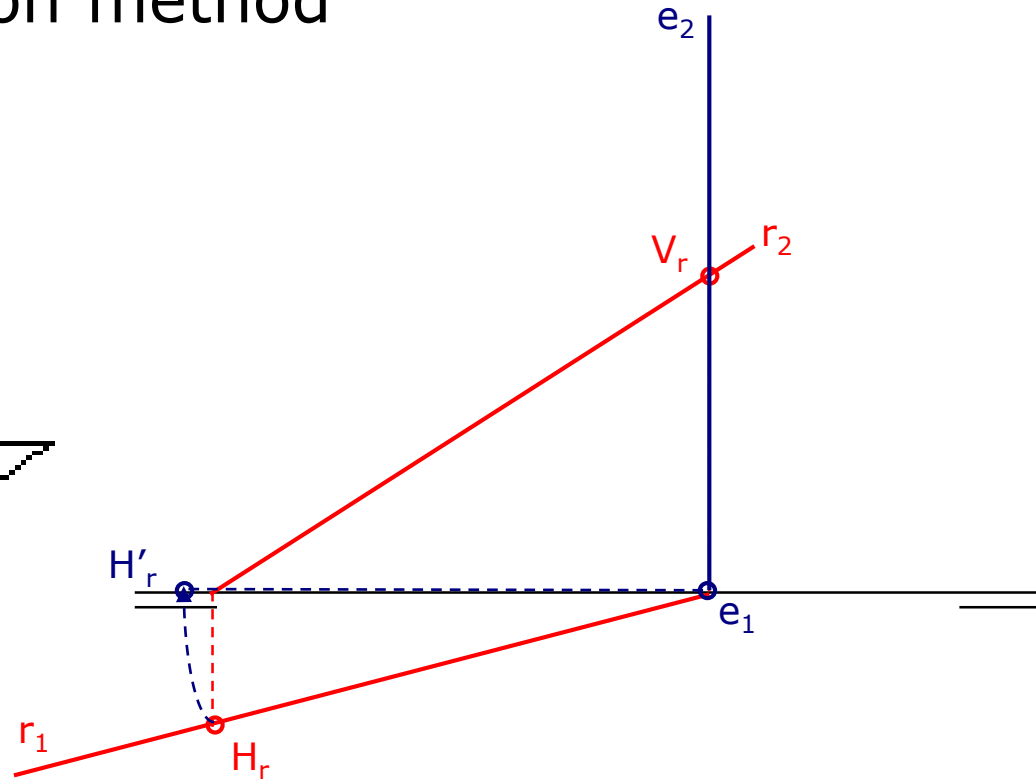
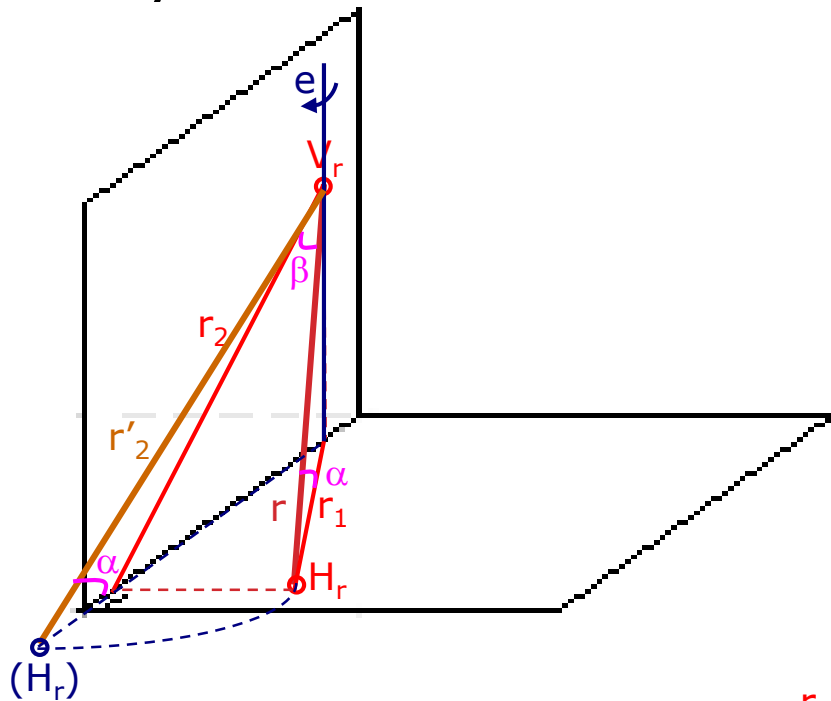

Angles of a line with respect to the projection planes II

- By means of revolution method

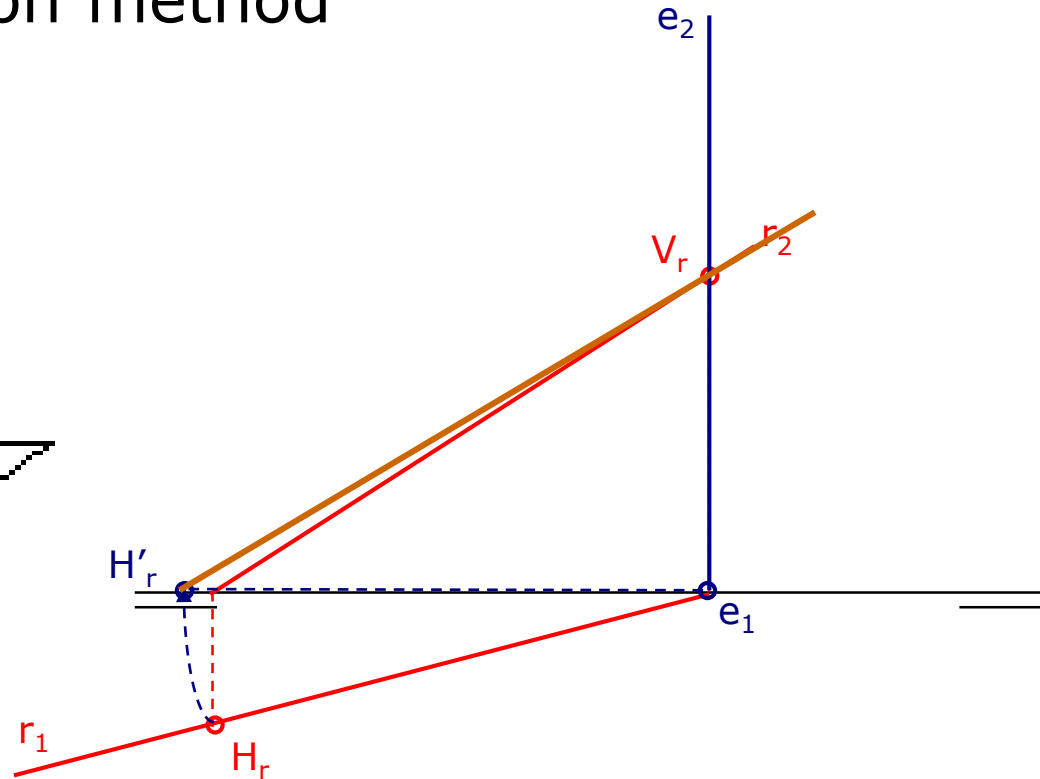
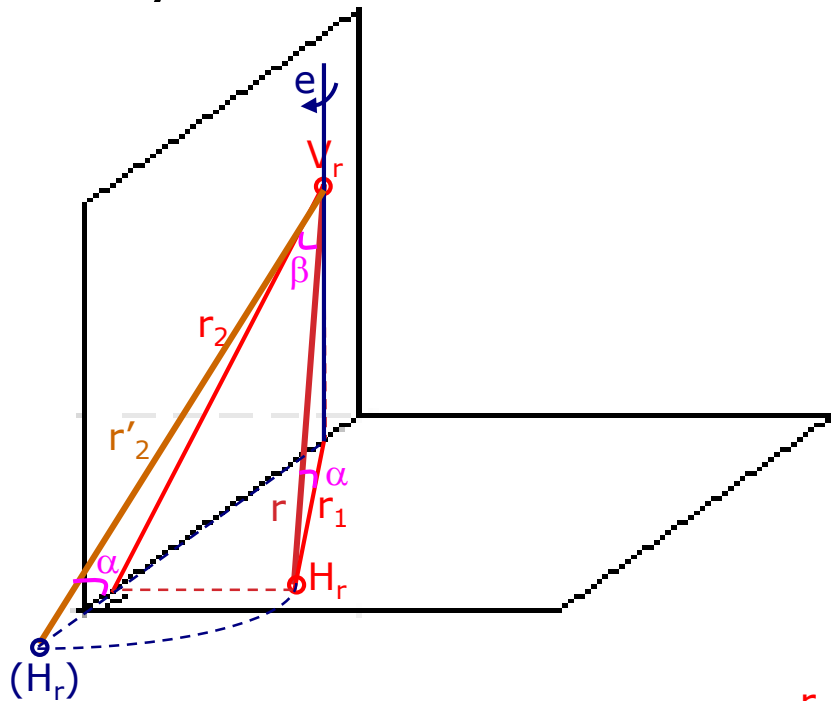

Angles of a line with respect to the projection planes II

□ By means of revolution method

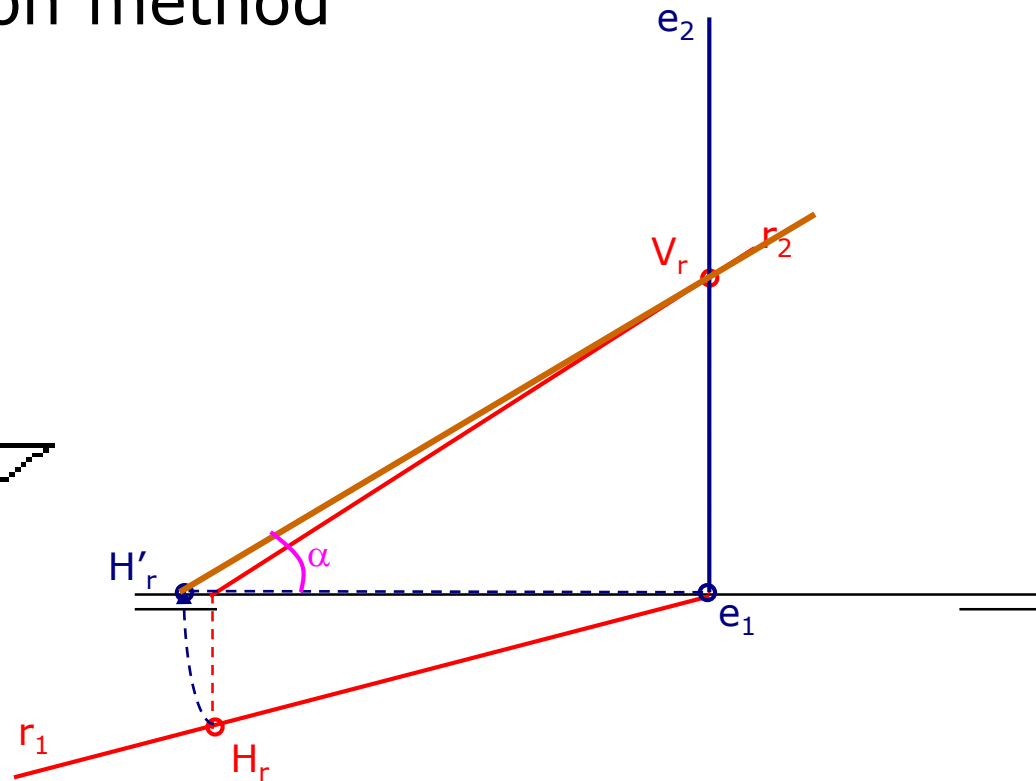
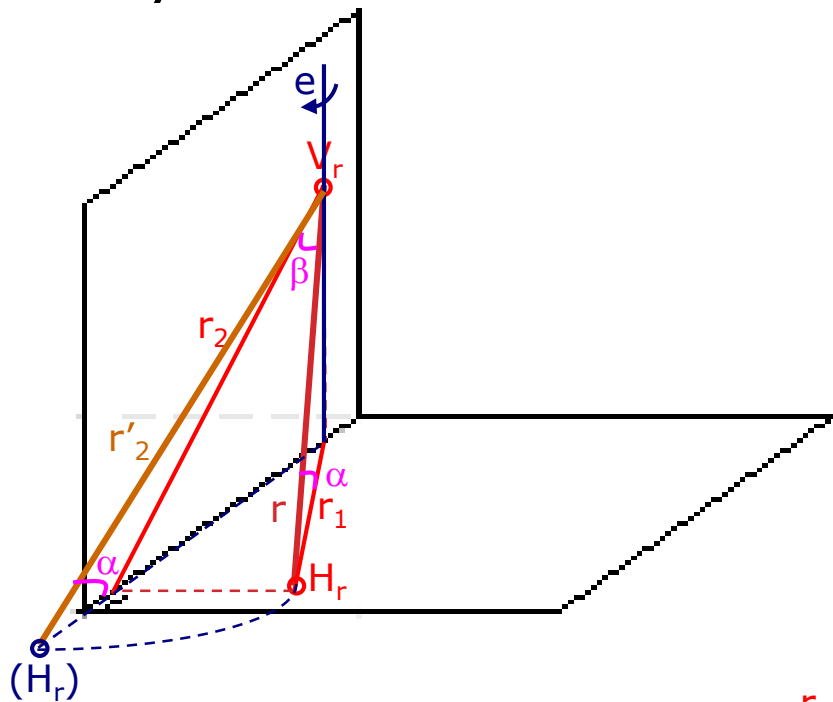

Angles of a line with respect to the projection planes II

- By means of revolution method

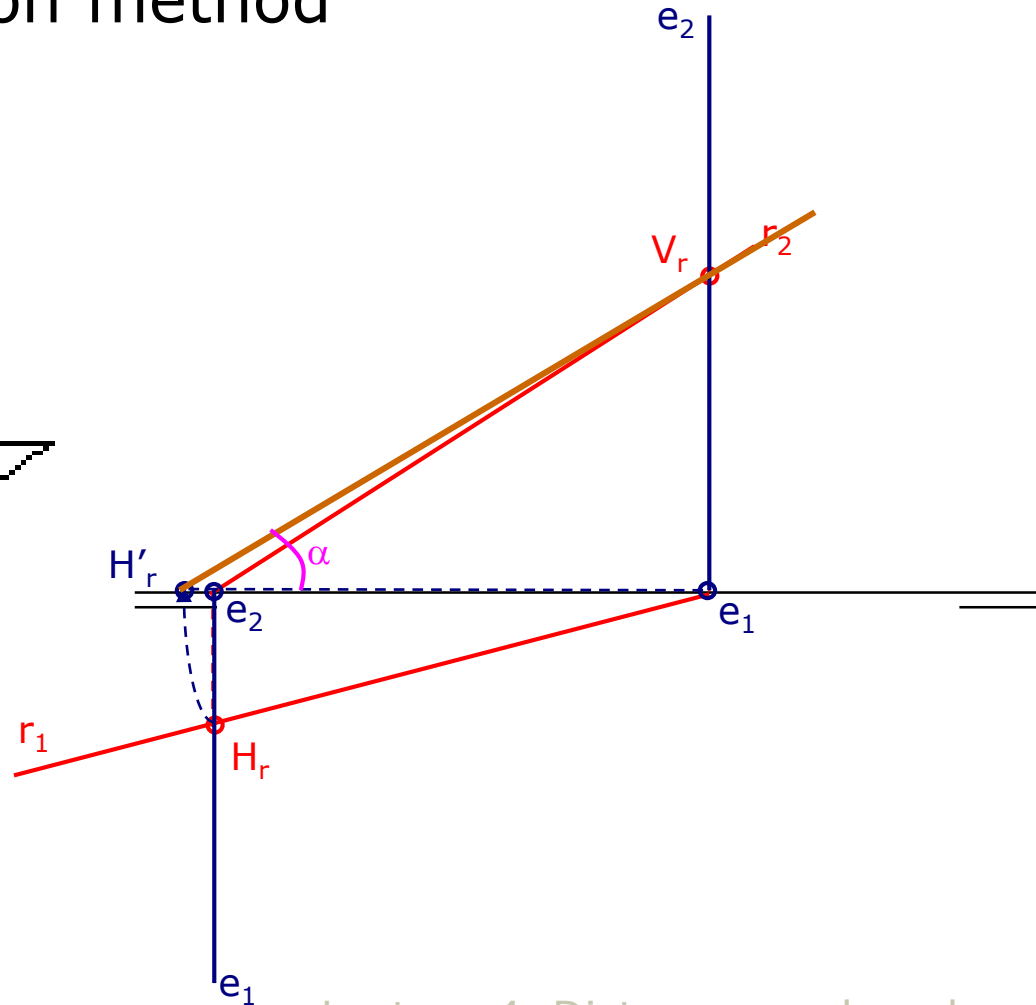
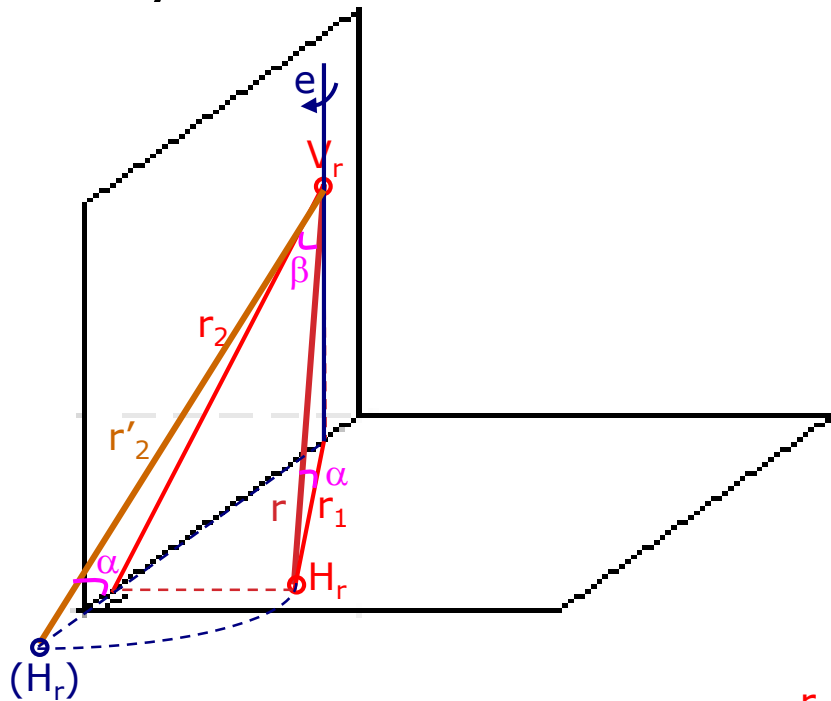

Angles of a line with respect to the projection planes II

- By means of revolution method

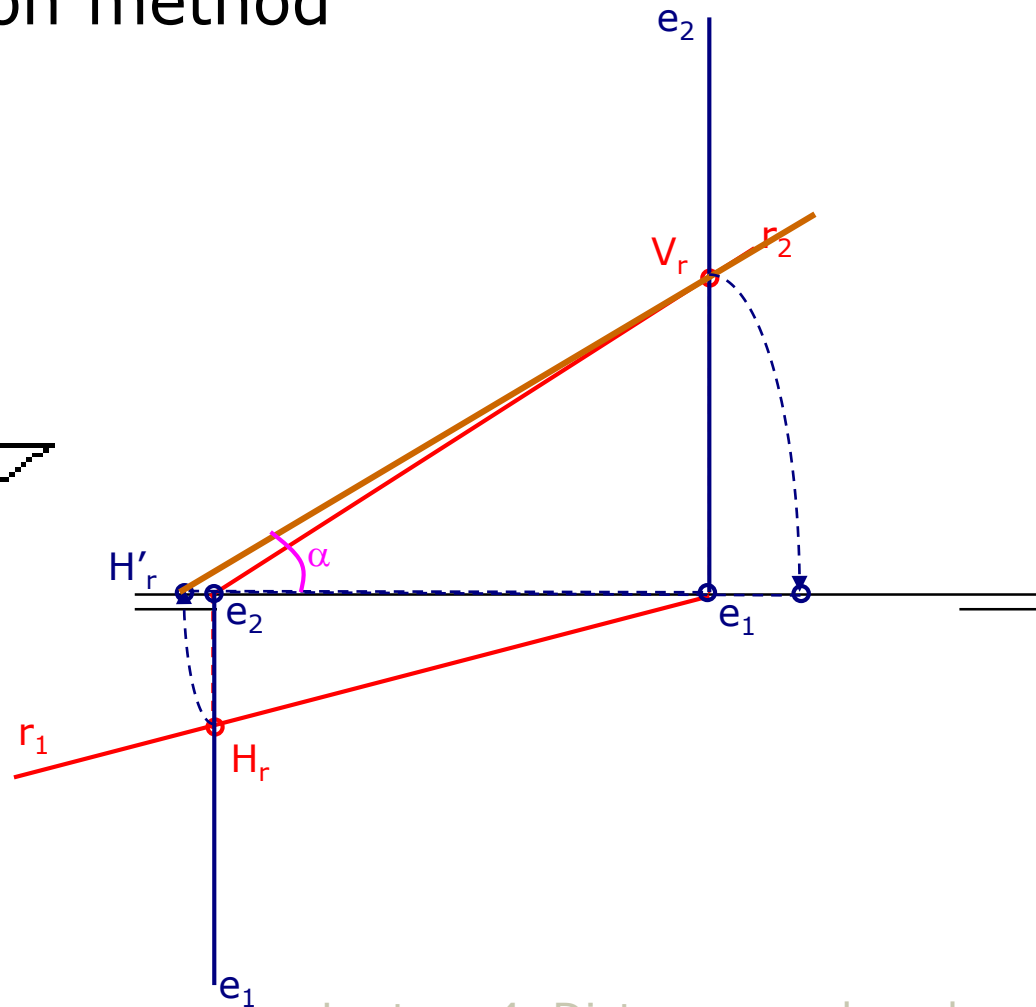
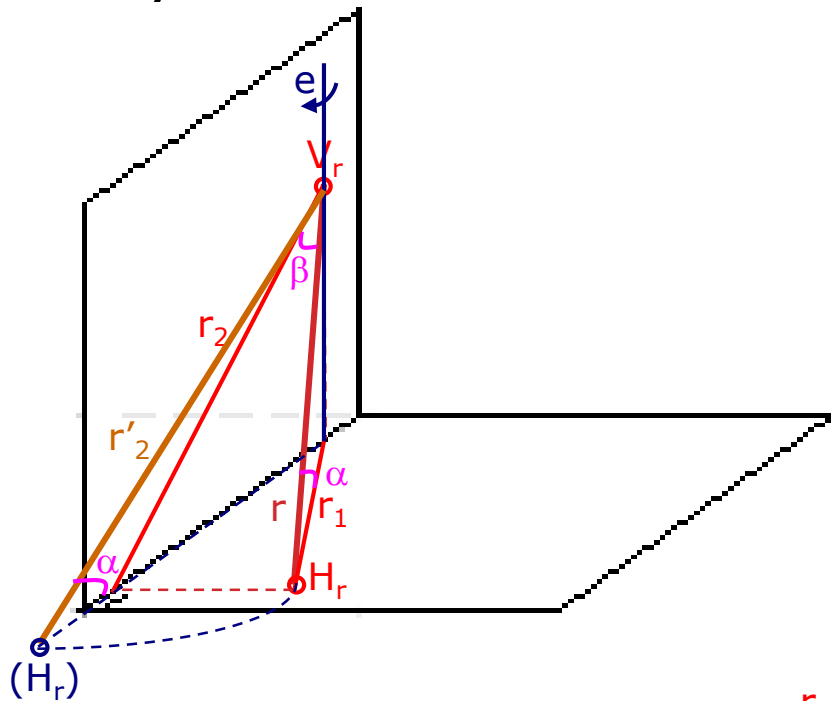

Angles of a line with respect to the projection planes II

- By means of revolution method

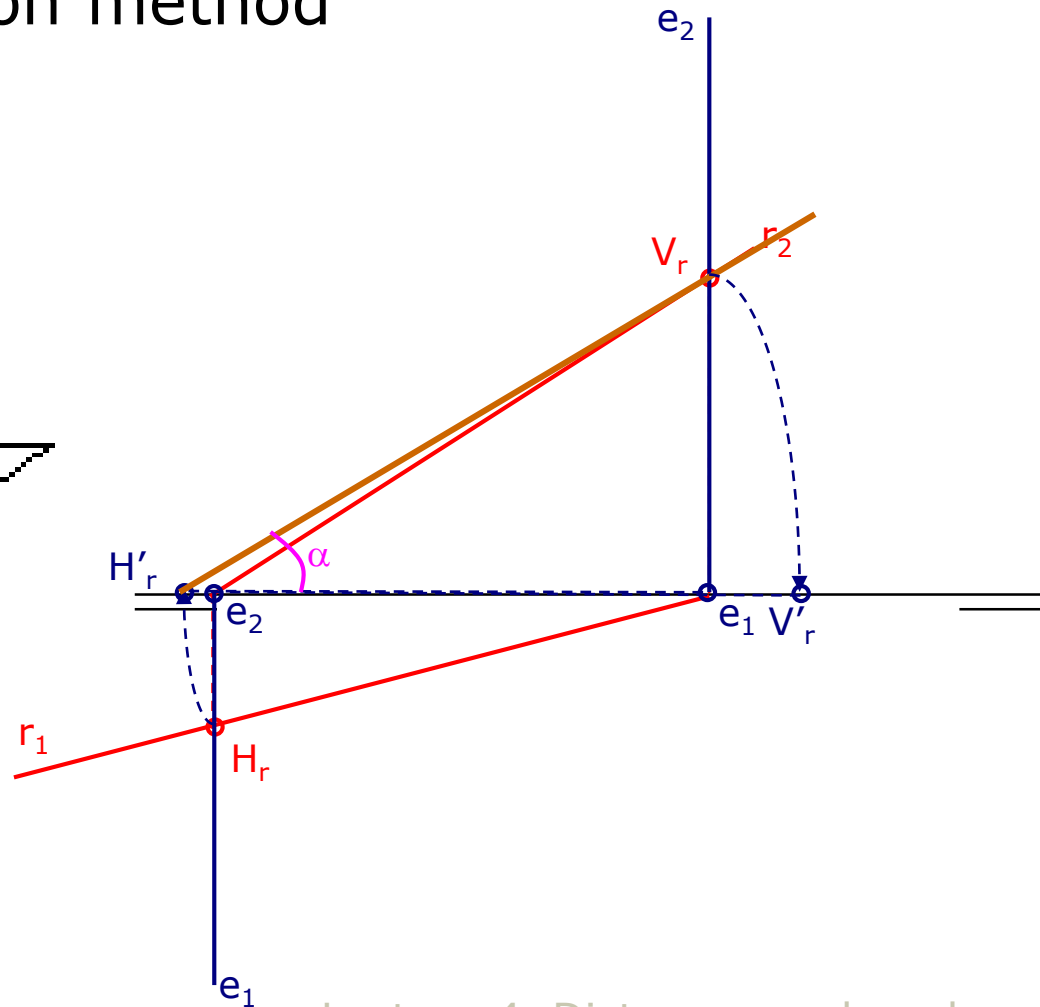
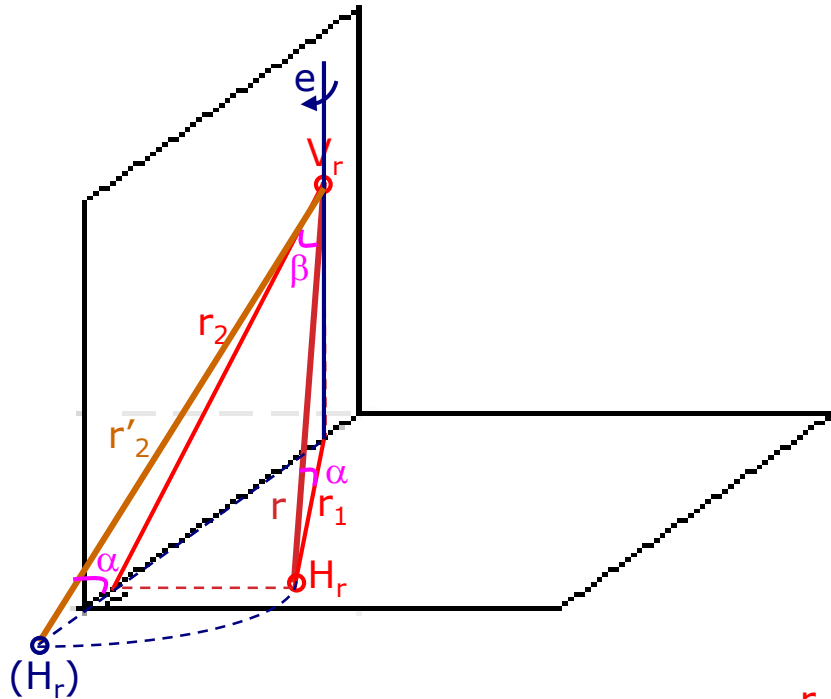

Angles of a line with respect to the projection planes II

- By means of revolution method

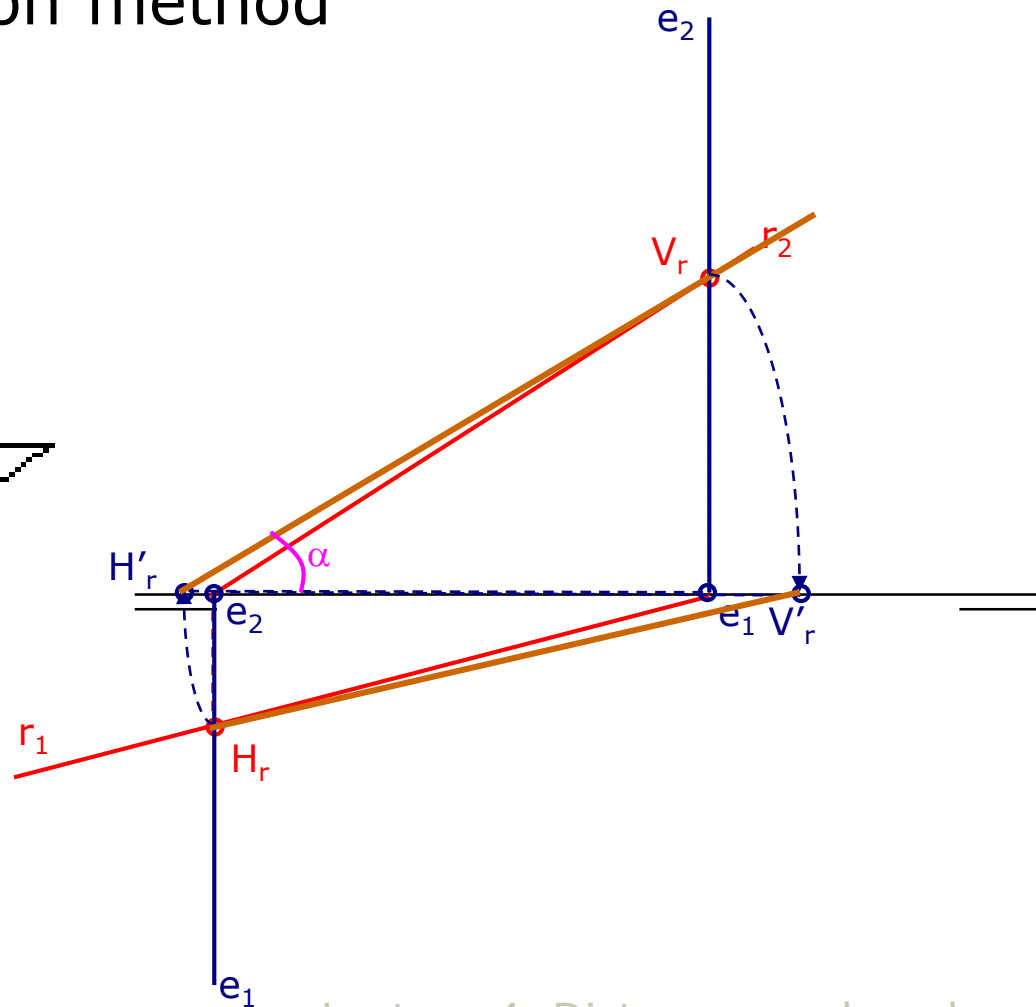
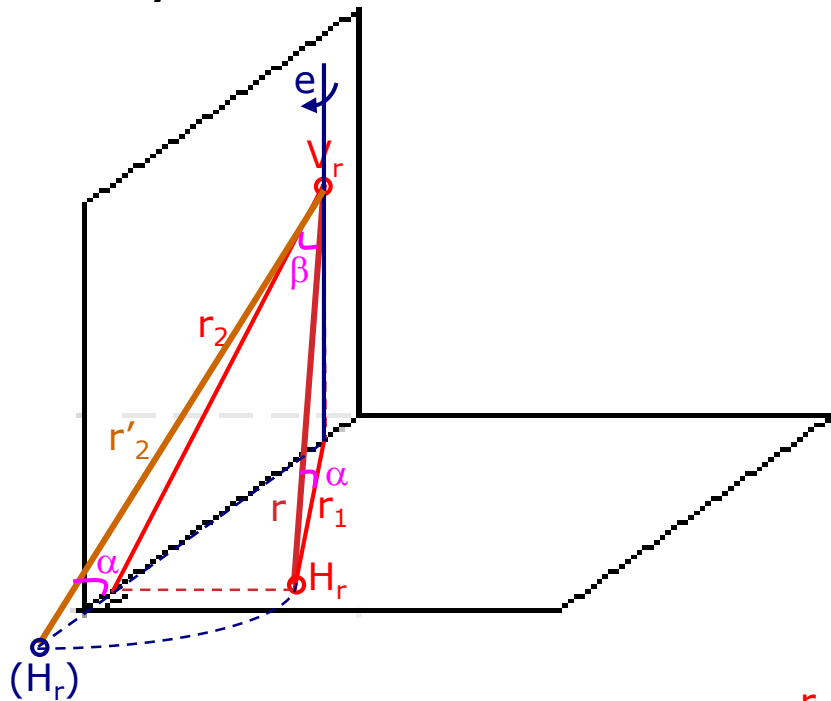

Angles of a line with respect to the projection planes II

- By means of revolution method

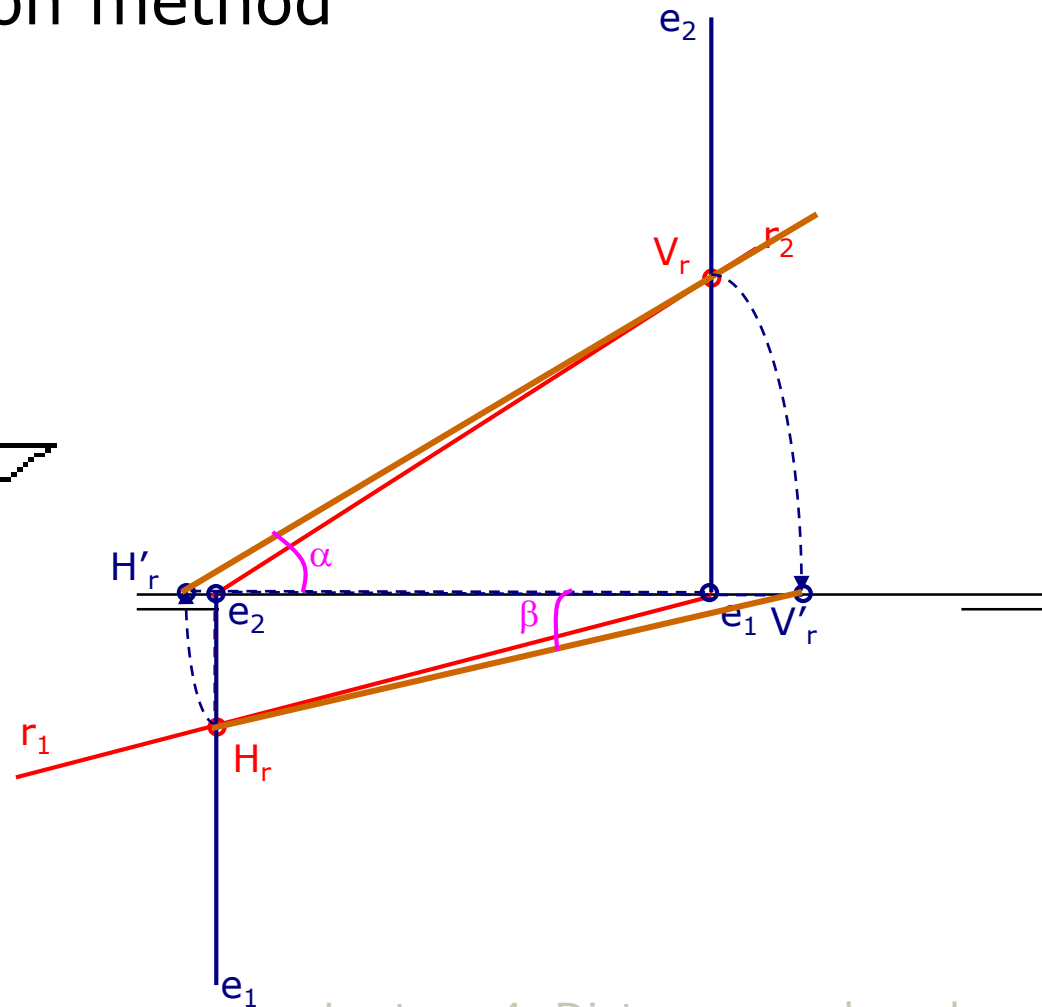
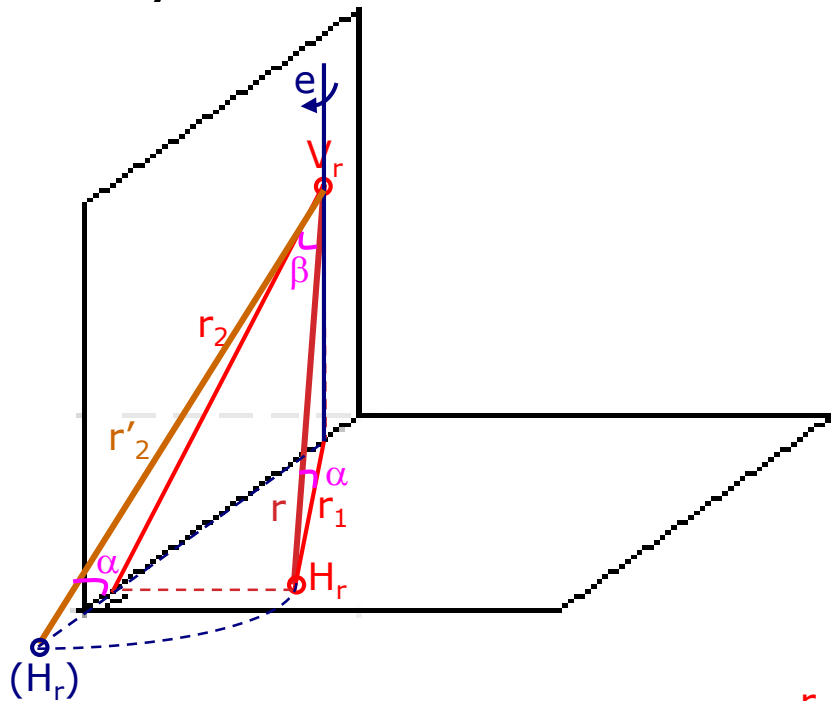

Angles of a line with respect to the projection planes II

- By means of revolution method

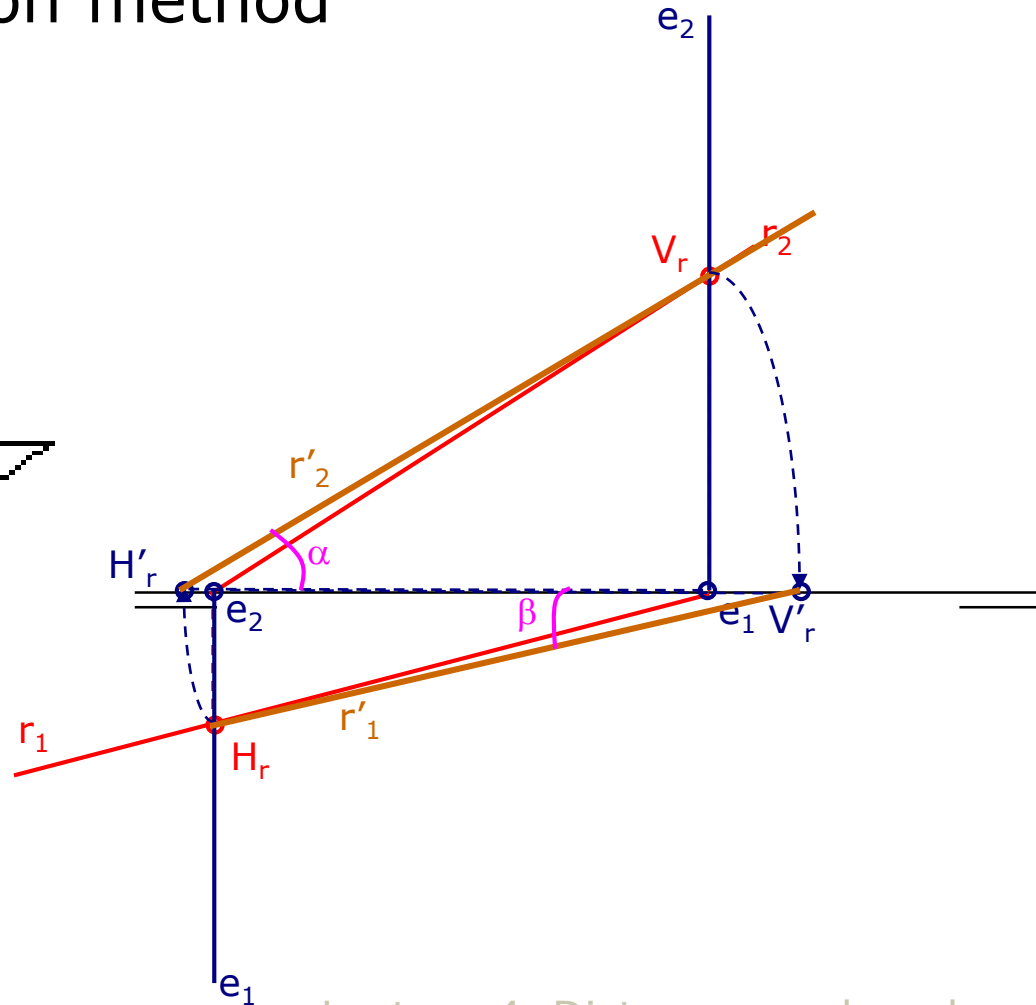
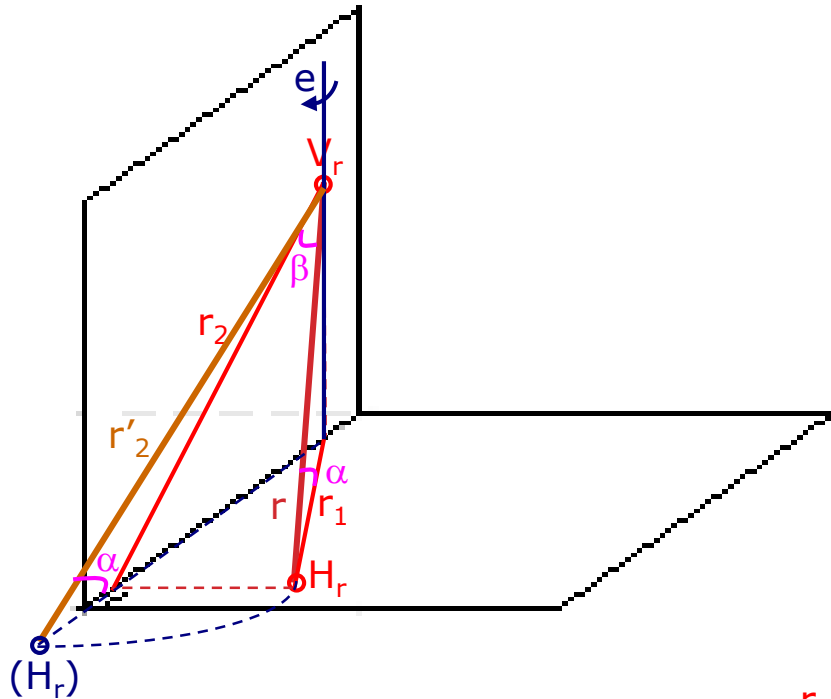

Angles of a plane with respect to the horizontal projection plane

- Is the same angle as the angle formed between the maximum slope line and the horizontal projection plane

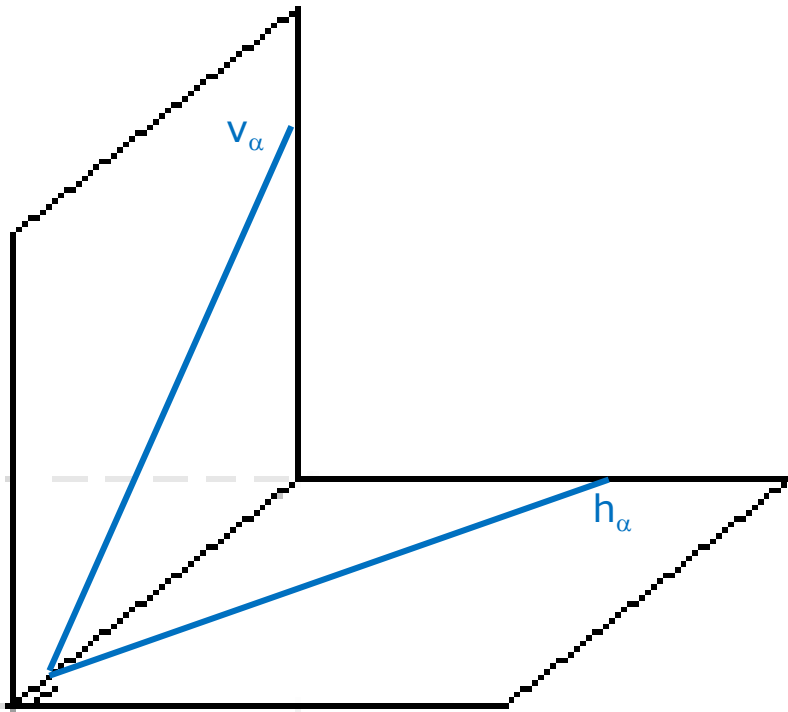

Angles of a plane with respect to the horizontal projection plane

- Is the same angle as the angle formed between the maximum slope line and the horizontal projection plane

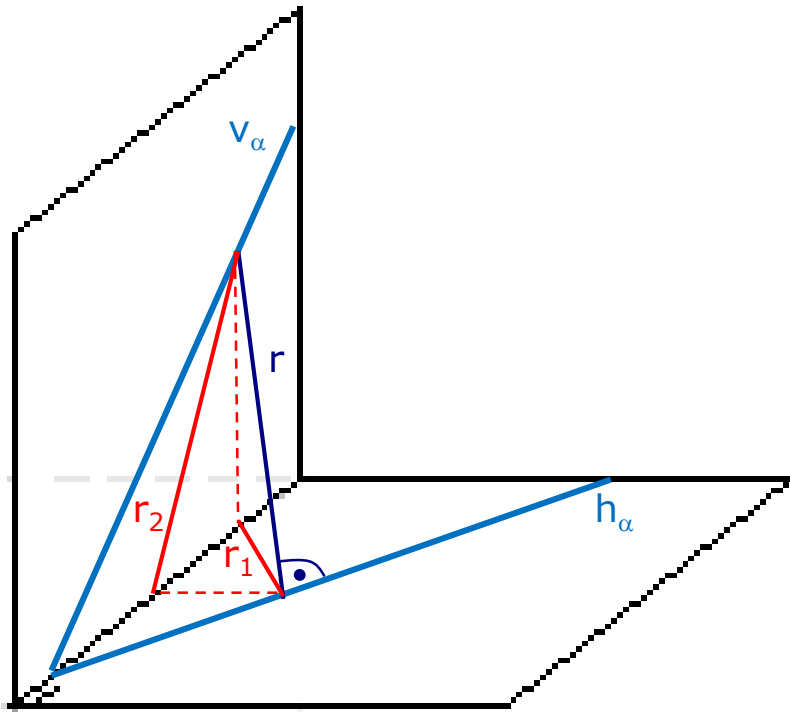

Angles of a plane with respect to the horizontal projection plane

- Is the same angle as the angle formed between the maximum slope line and the horizontal projection plane

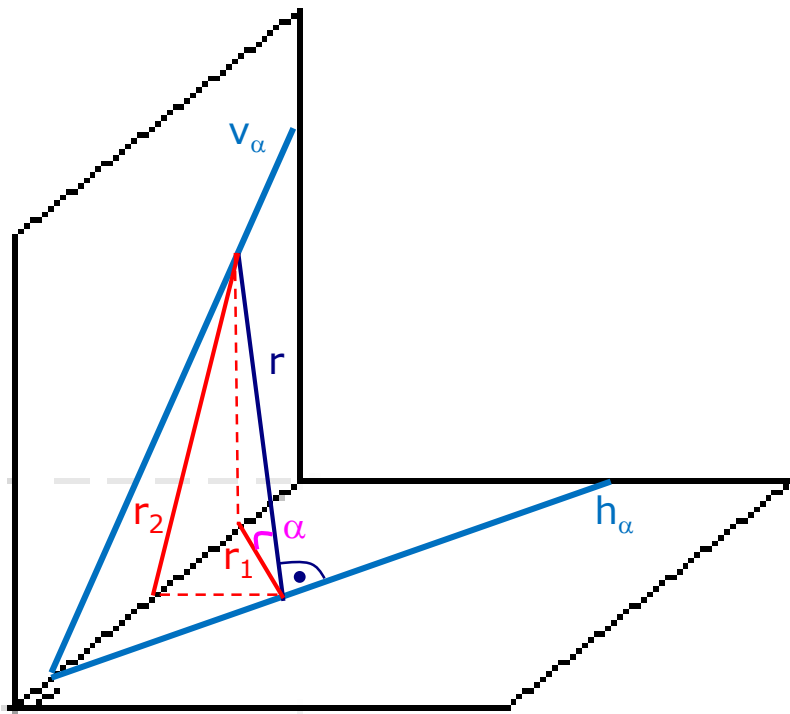

Angles of a plane with respect to the horizontal projection plane

- Is the same angle as the angle formed between the maximum slope line and the horizontal projection plane

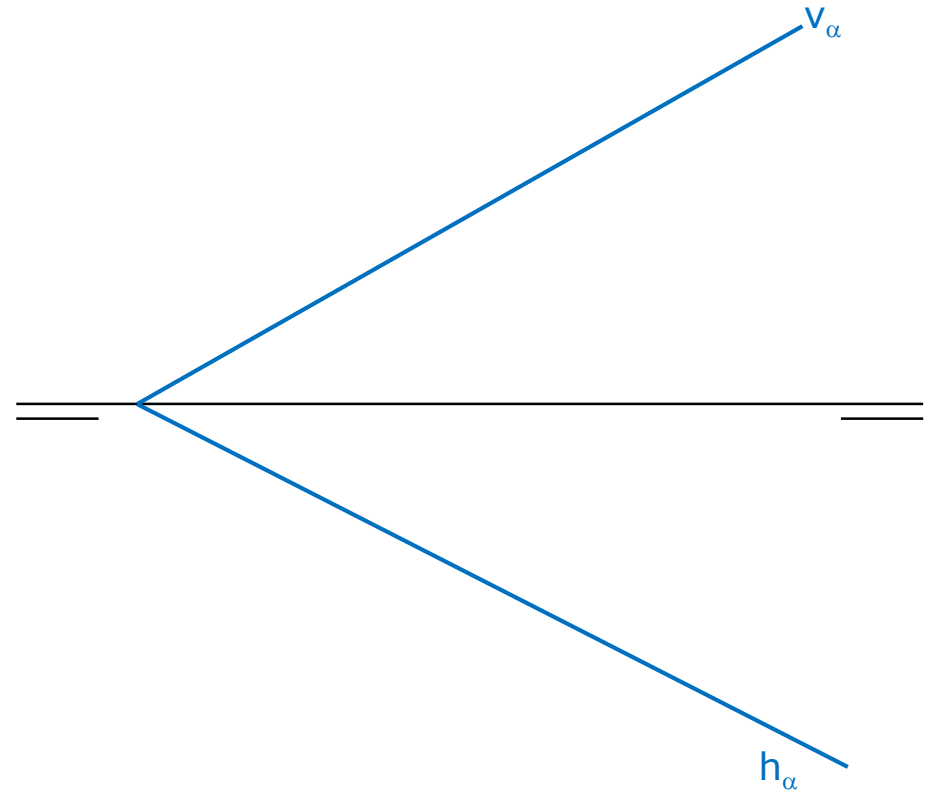
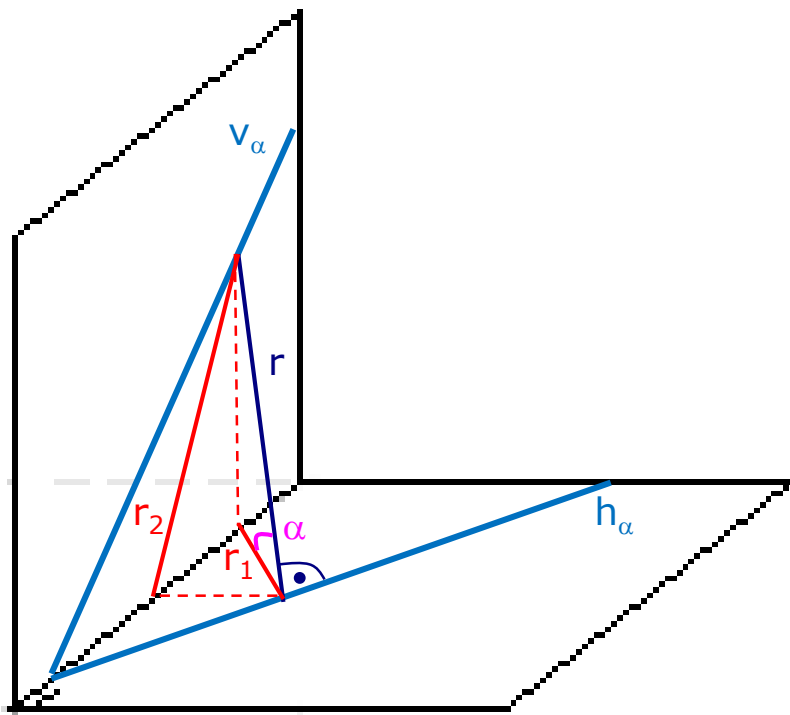

Angles of a plane with respect to the horizontal projection plane

- Is the same angle as the angle formed between the maximum slope line and the horizontal projection plane

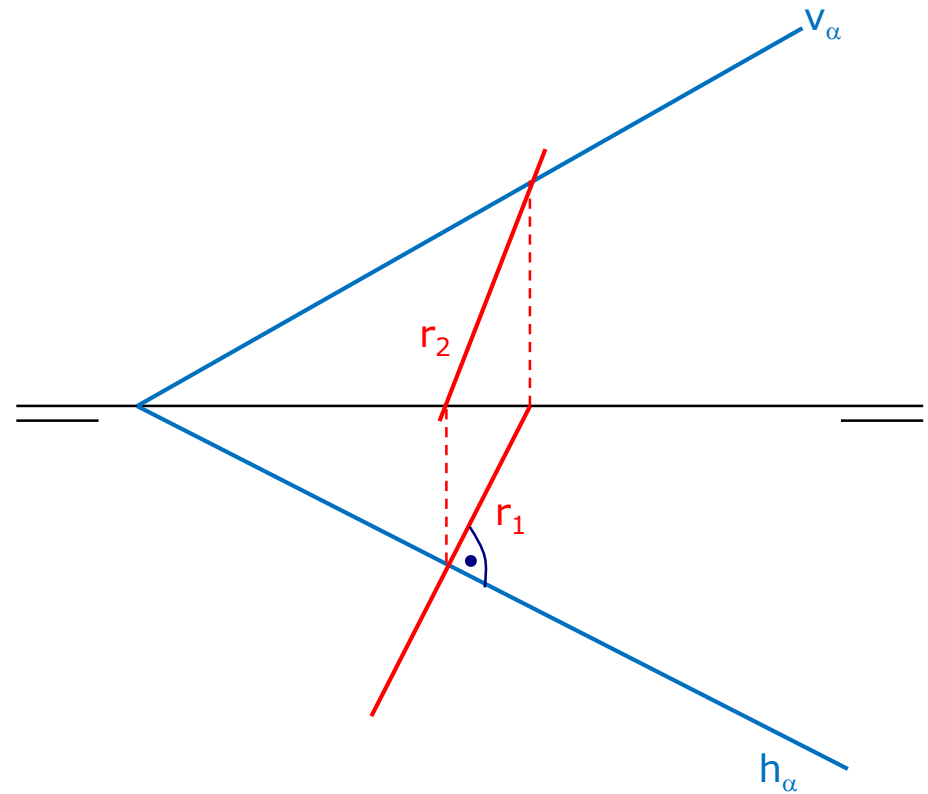
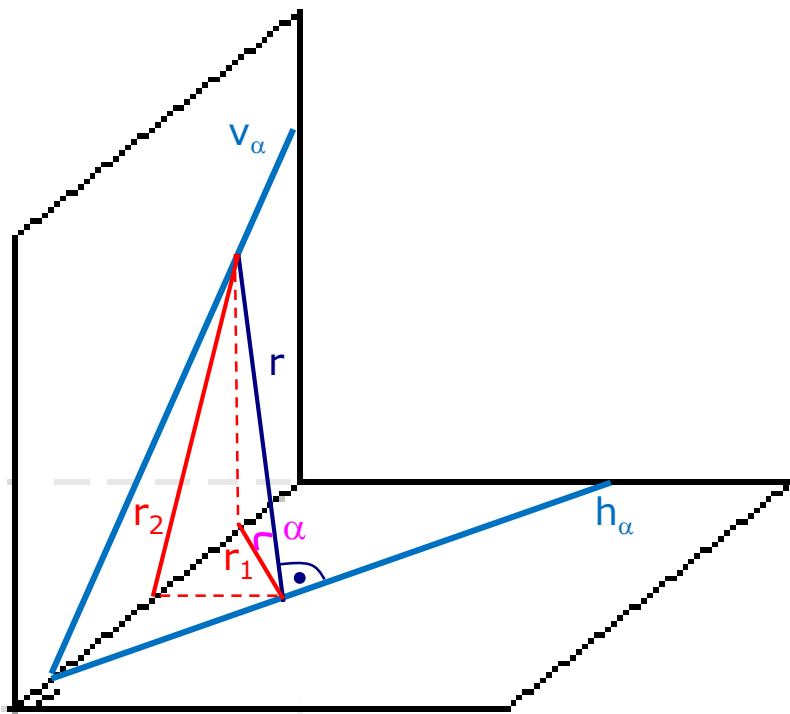

Angles of a plane with respect to the horizontal projection plane

- Is the same angle as the angle formed between the maximum slope line and the horizontal projection plane

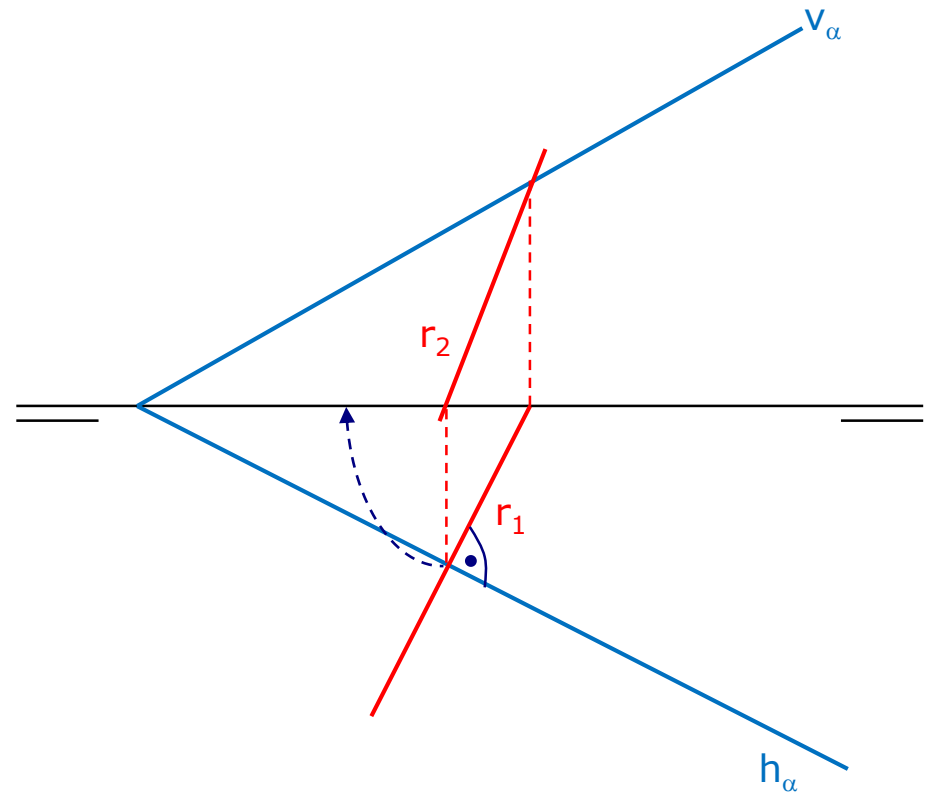
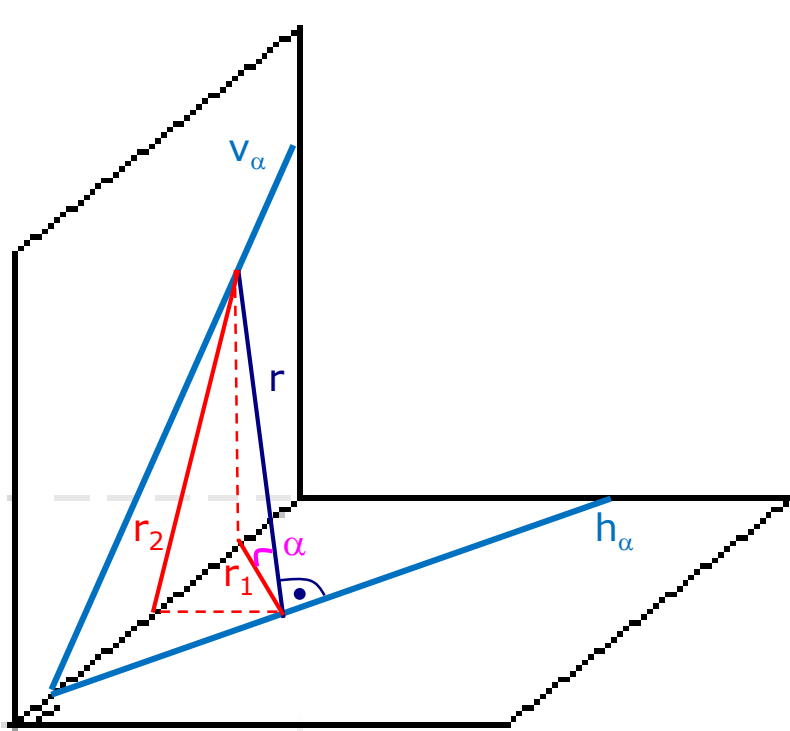

Angles of a plane with respect to the horizontal projection plane

- Is the same angle as the angle formed between the maximum slope line and the horizontal projection plane

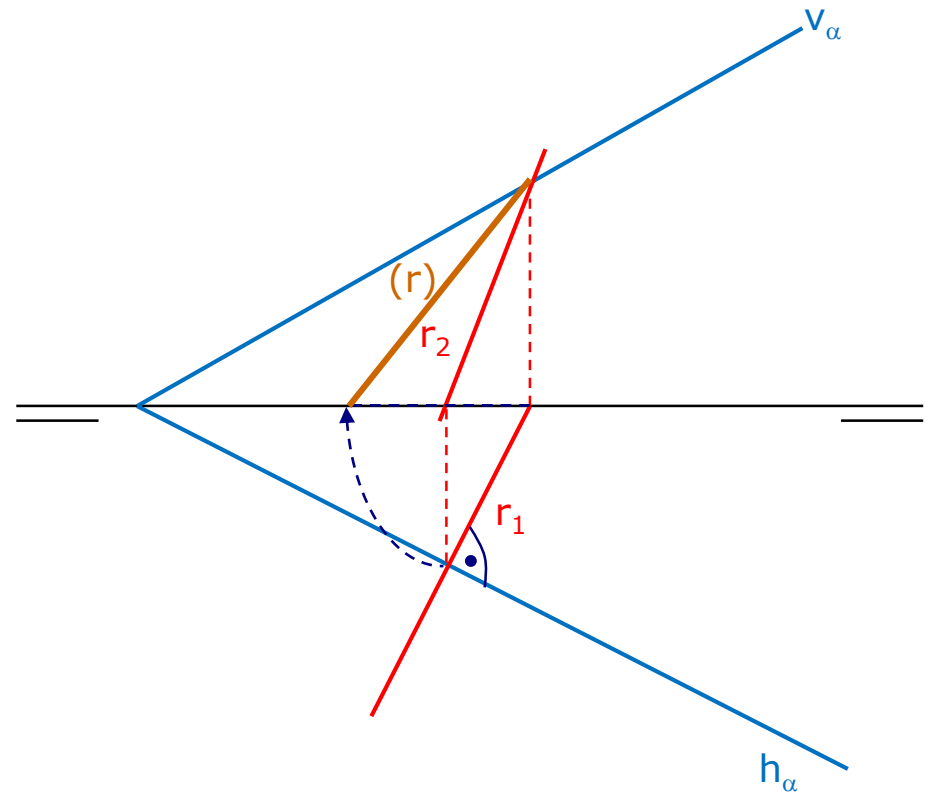
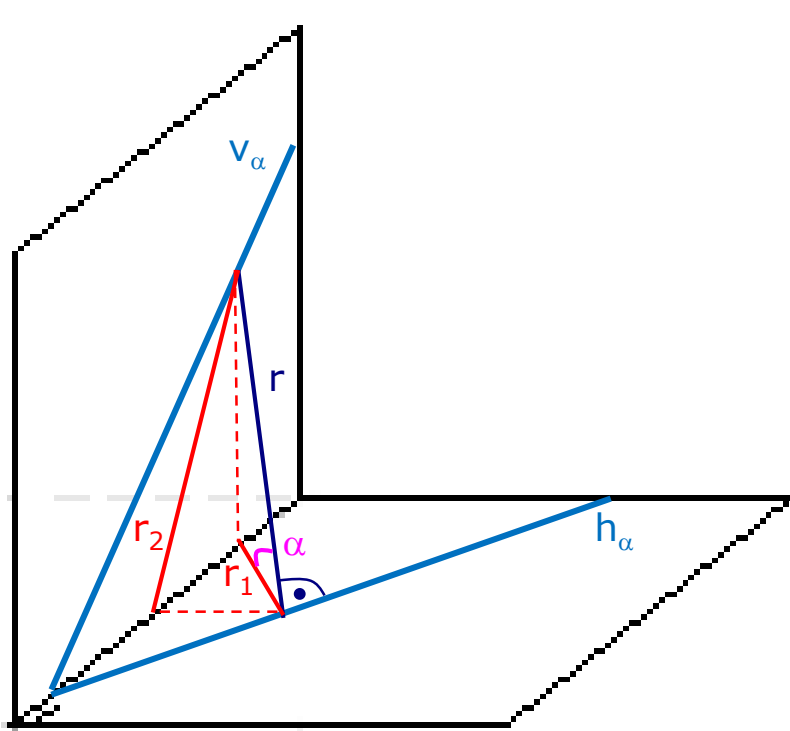

Angles of a plane with respect to the horizontal projection plane

- Is the same angle as the angle formed between the maximum slope line and the horizontal projection plane

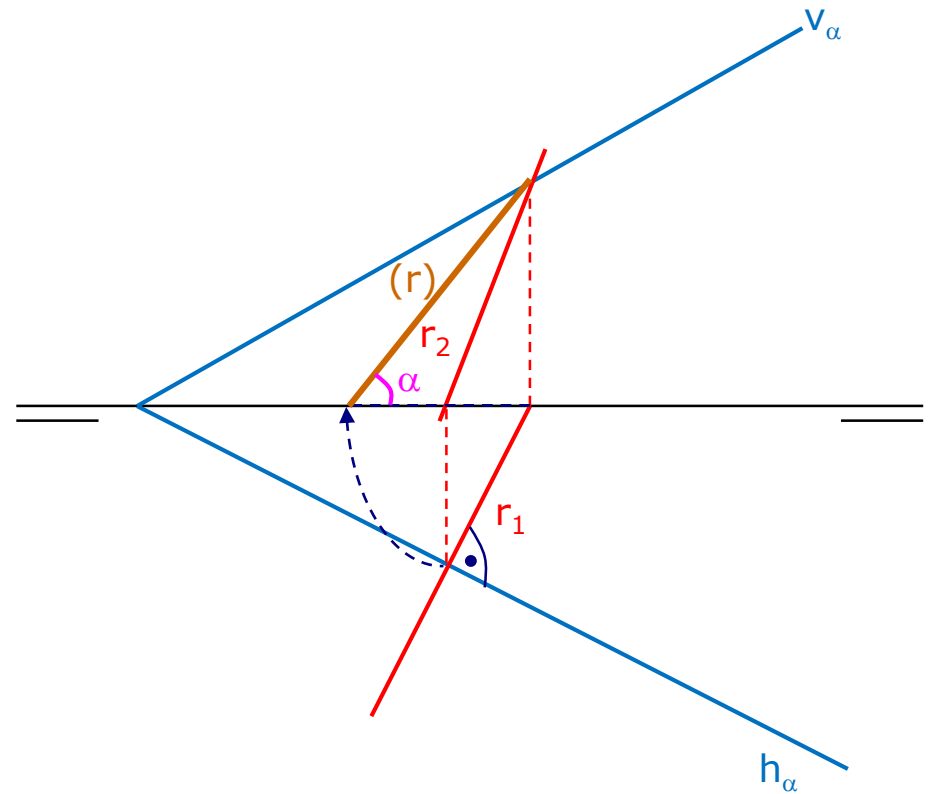
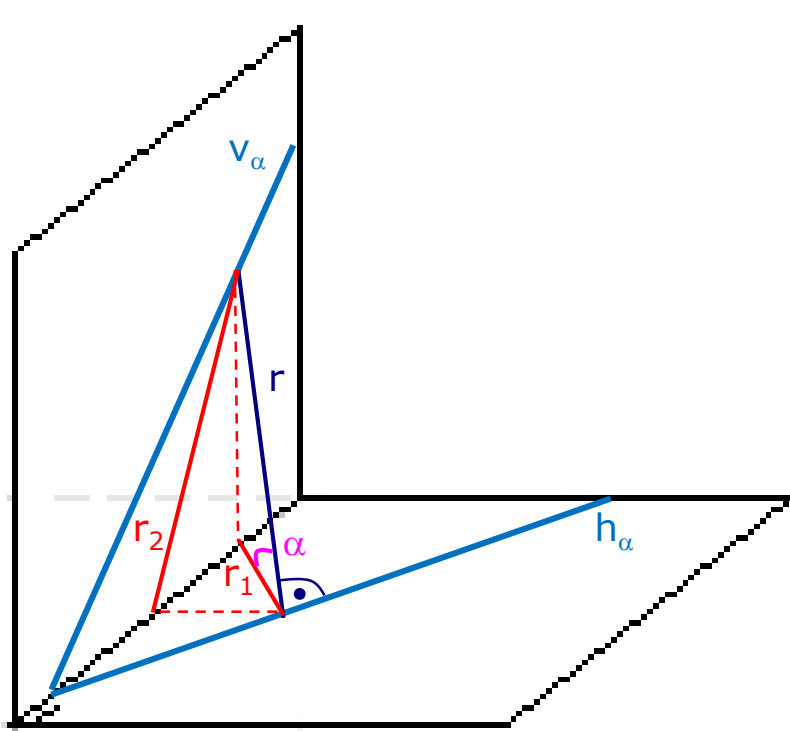

Angles of a plane with respect to the vertical projection plane

- Is the same angle that is formed between the maximum inclination line and the vertical projection plane

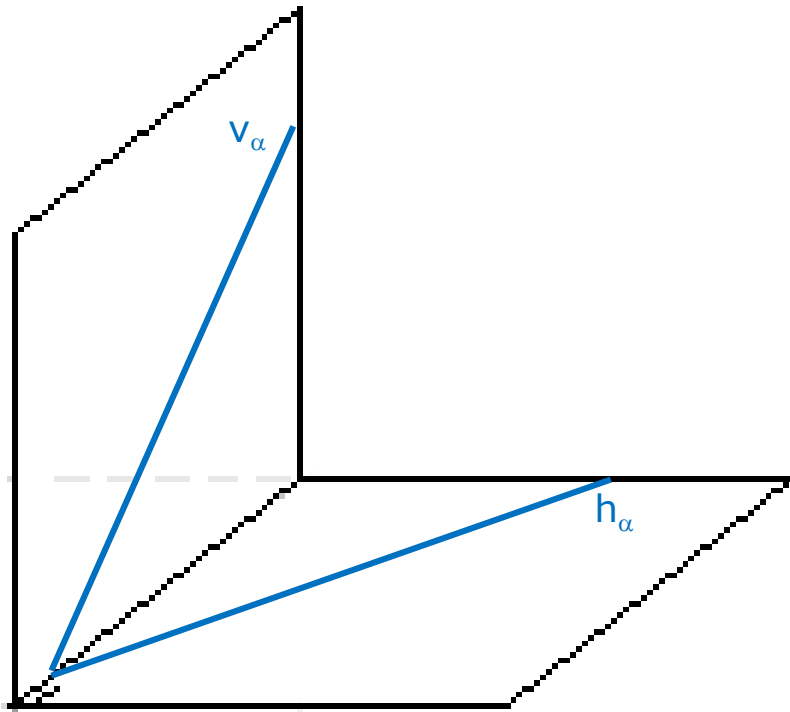

Angles of a plane with respect to the vertical projection plane

- Is the same angle that is formed between the maximum inclination line and the vertical projection plane

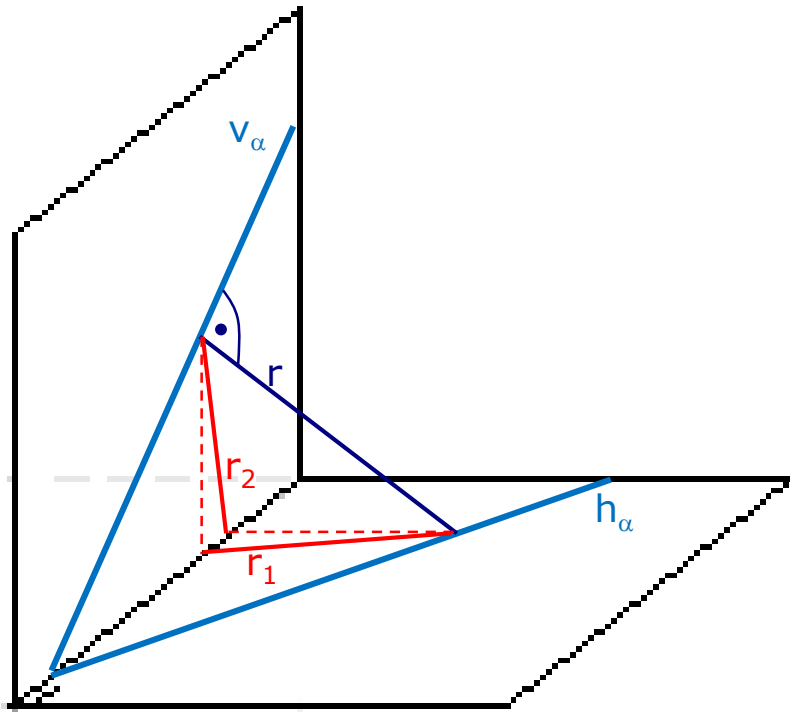

Angles of a plane with respect to the vertical projection plane

- Is the same angle that is formed between the maximum inclination line and the vertical projection plane

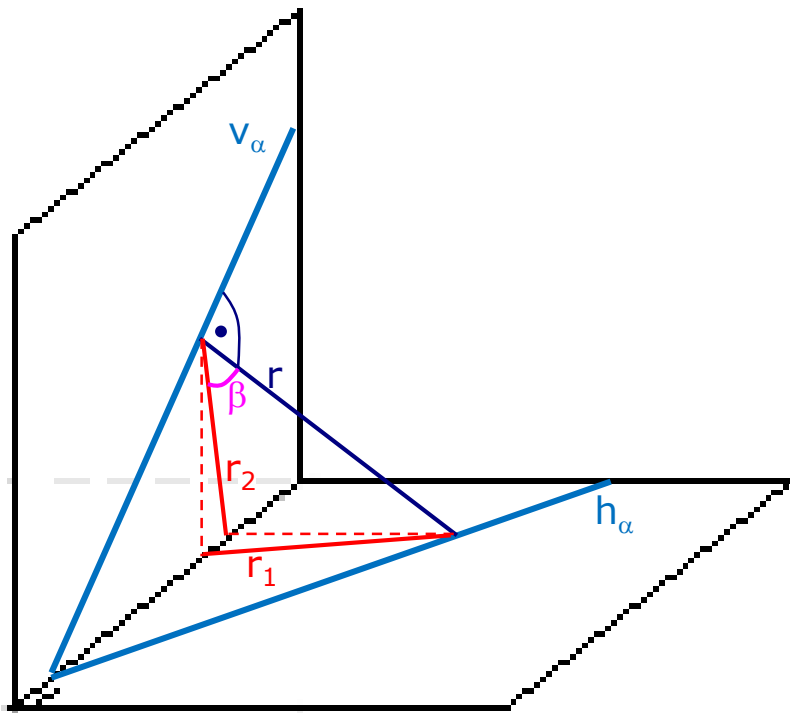

Angles of a plane with respect to the vertical projection plane

- Is the same angle that is formed between the maximum inclination line and the vertical projection plane

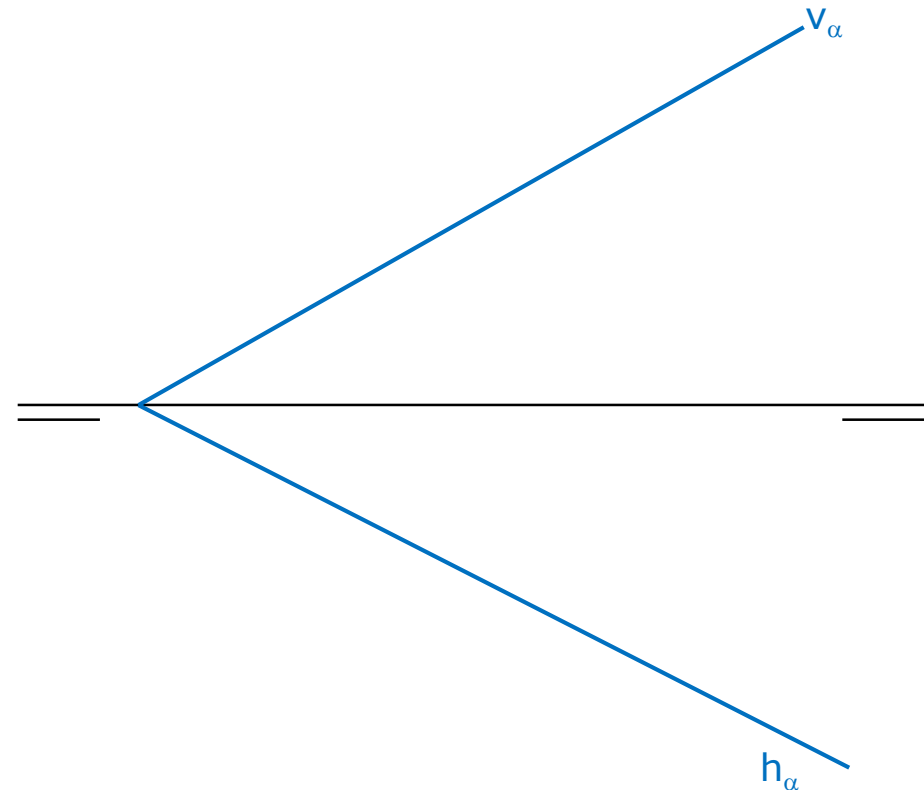
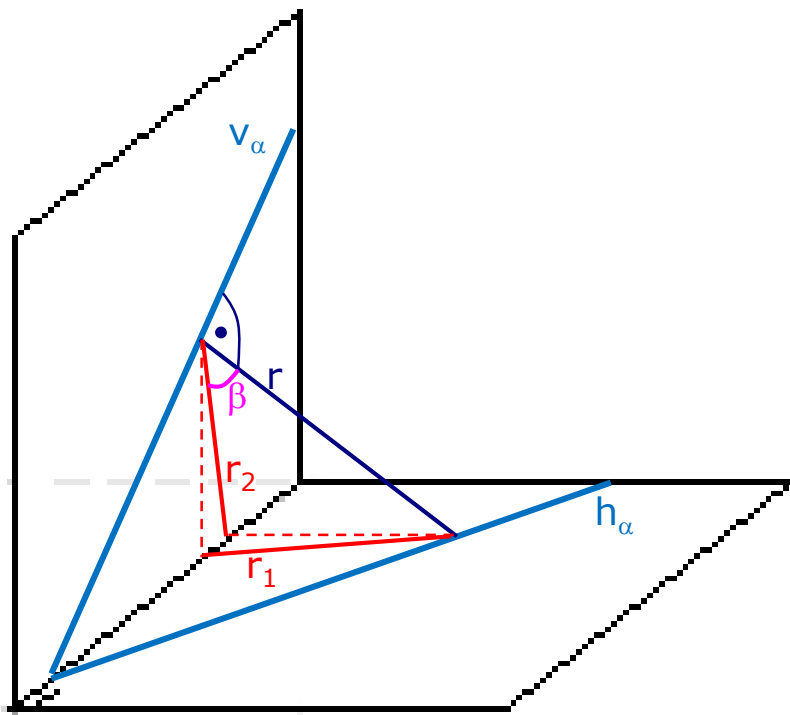

Angles of a plane with respect to the vertical projection plane

- Is the same angle that is formed between the maximum inclination line and the vertical projection plane

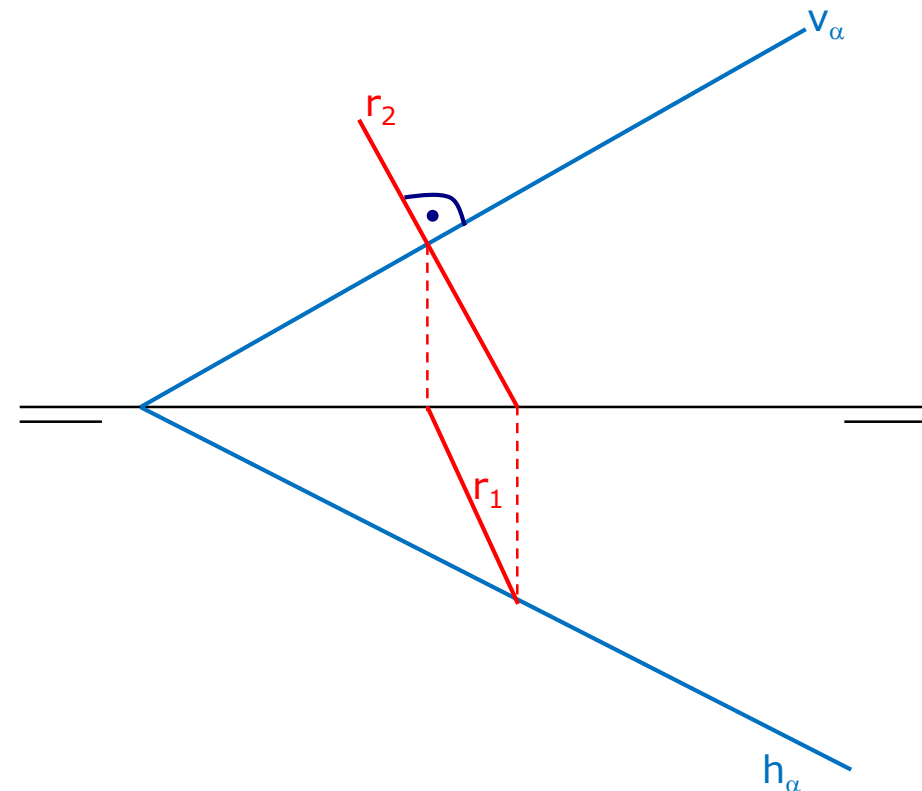
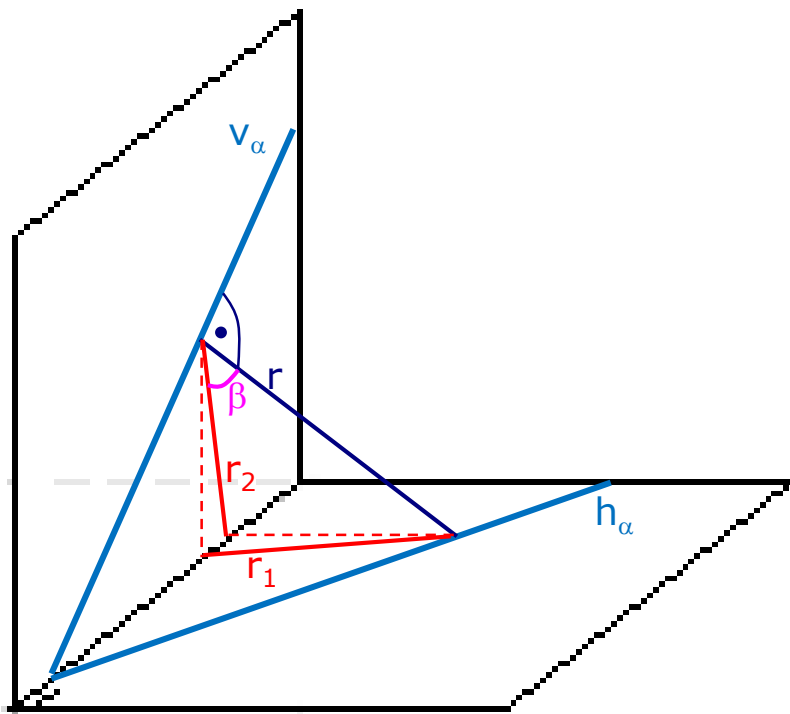

Angles of a plane with respect to the vertical projection plane

- Is the same angle that is formed between the maximum inclination line and the vertical projection plane

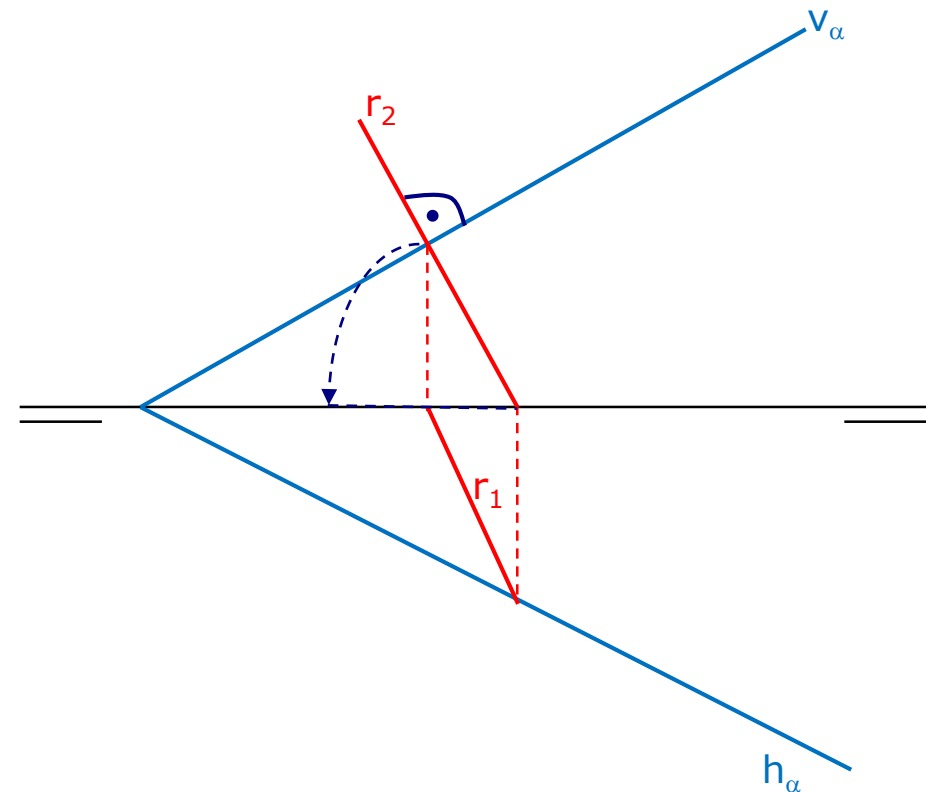
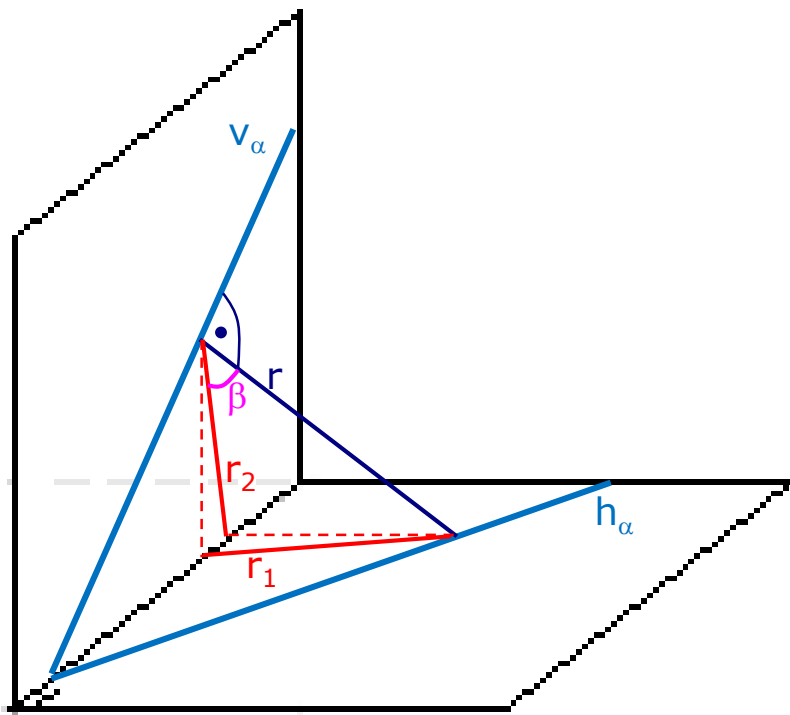

Angles of a plane with respect to the vertical projection plane

- Is the same angle that is formed between the maximum inclination line and the vertical projection plane

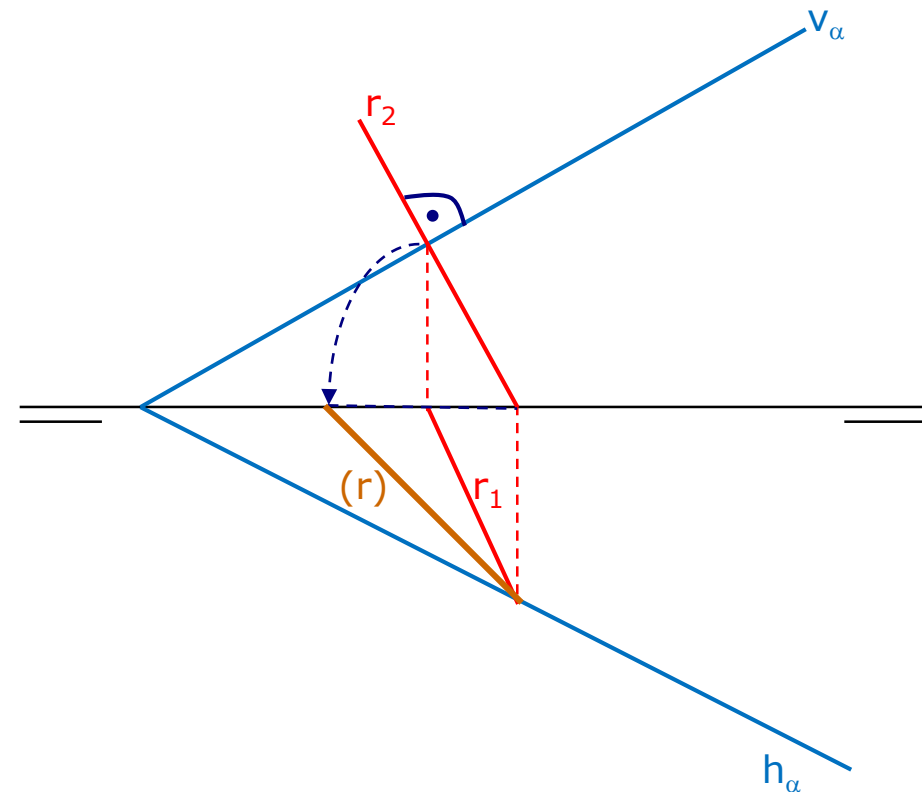
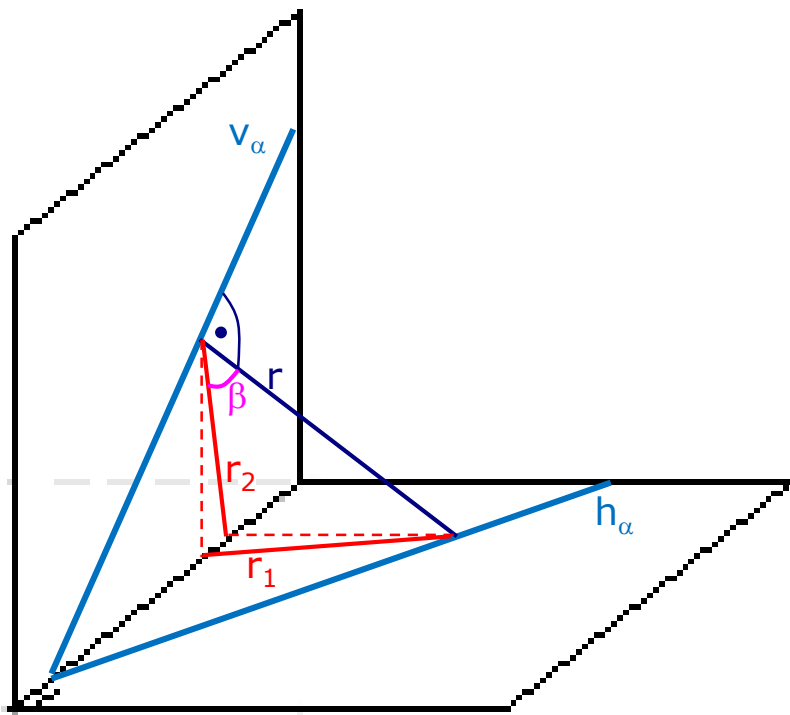

Angles of a plane with respect to the vertical projection plane

- Is the same angle that is formed between the maximum inclination line and the vertical projection plane

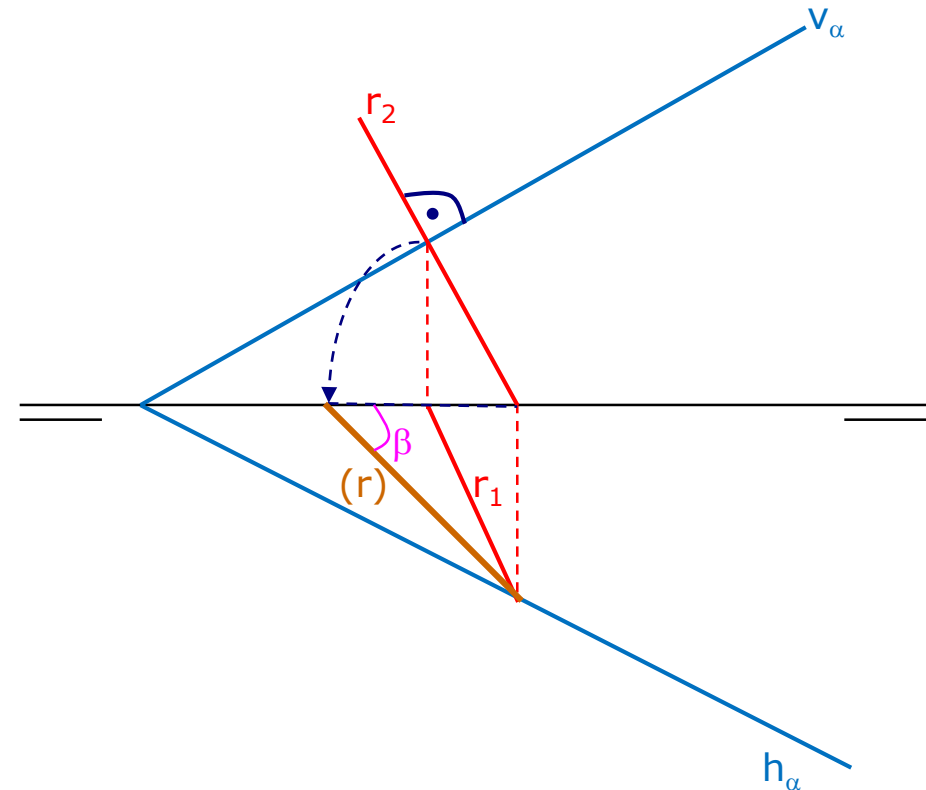
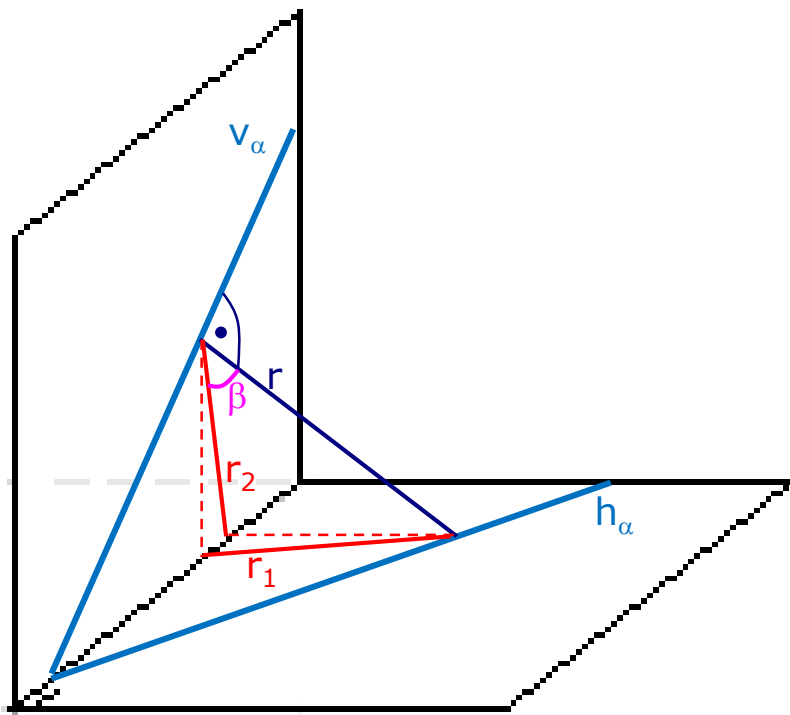

Construction of angles I

- For the construction of geometric elements that have a certain angle with other elements that are already given, it is very useful to construct a regular cone.
- The generatrix lines of a regular cone have the same angle with respect to its base.

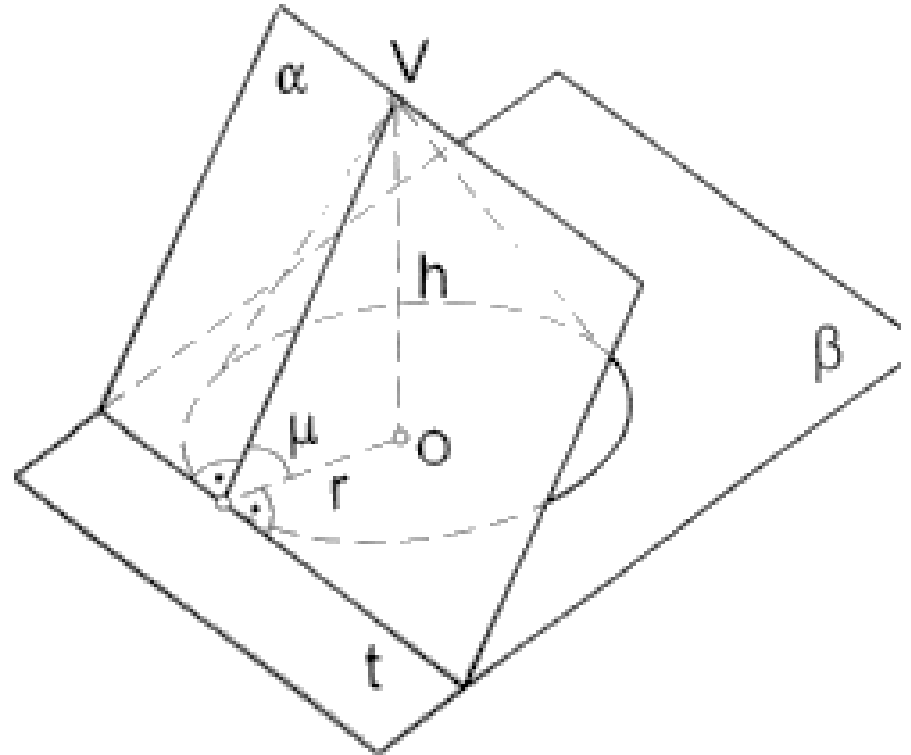

Construction of angles II

- Construction of lines and planes that form a certain angle θ with the horizontal plane and passes through point V.

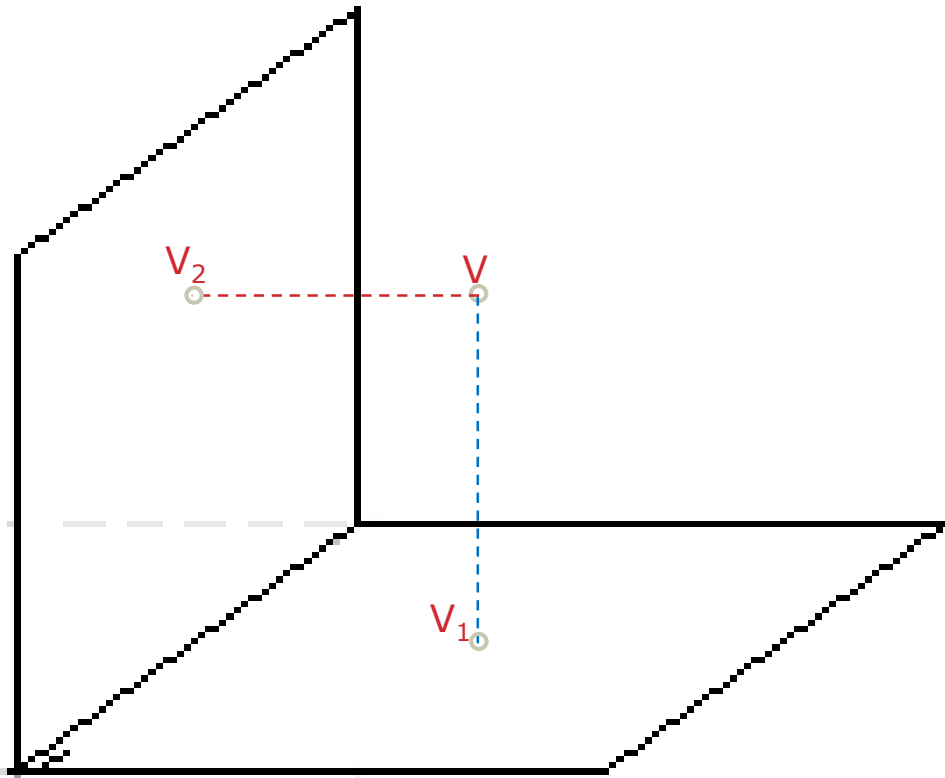

Construction of angles II

- Construction of lines and planes that form a certain angle θ with the horizontal plane and passes through point V.

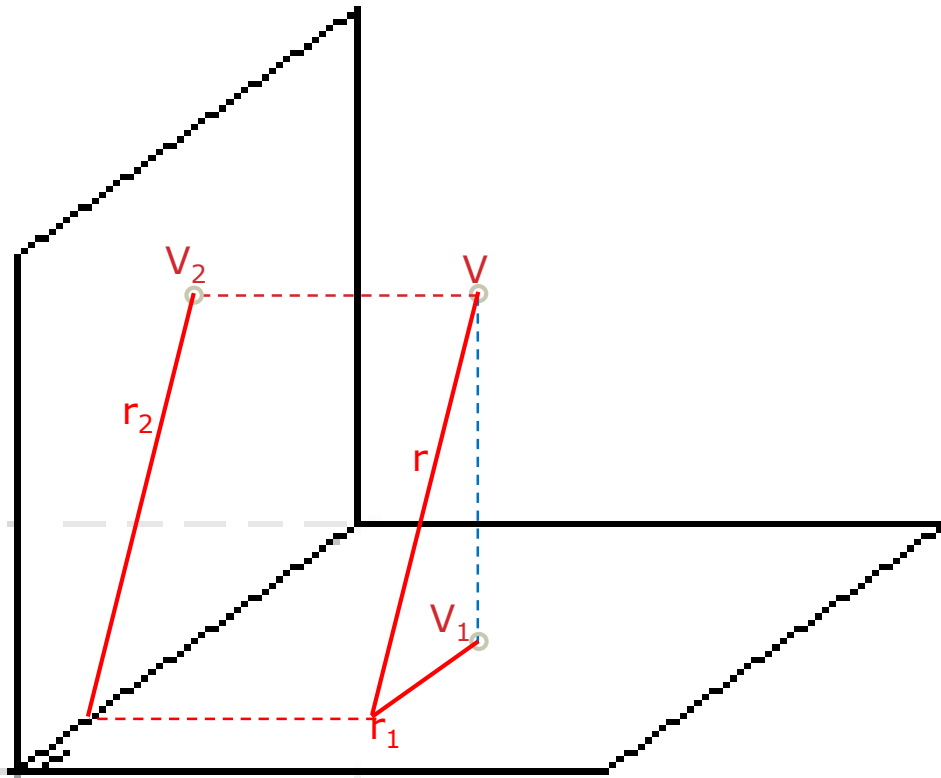

Construction of angles II

- Construction of lines and planes that form a certain angle θ with the horizontal plane and passes through point V.

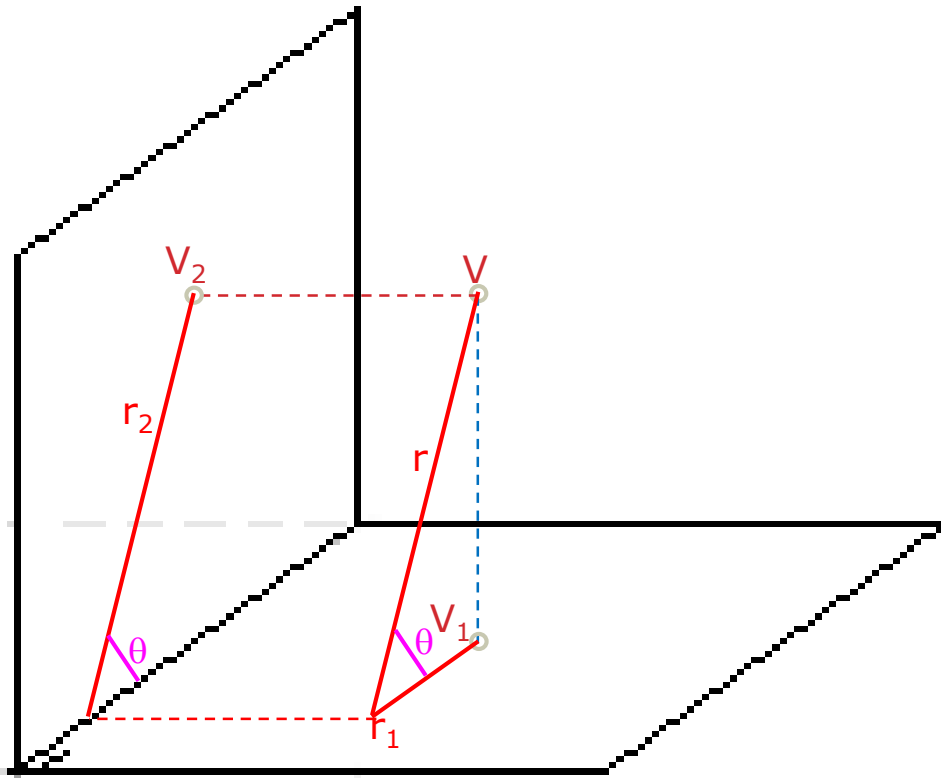

Construction of angles II

- Construction of lines and planes that form a certain angle θ with the horizontal plane and passes through point V.

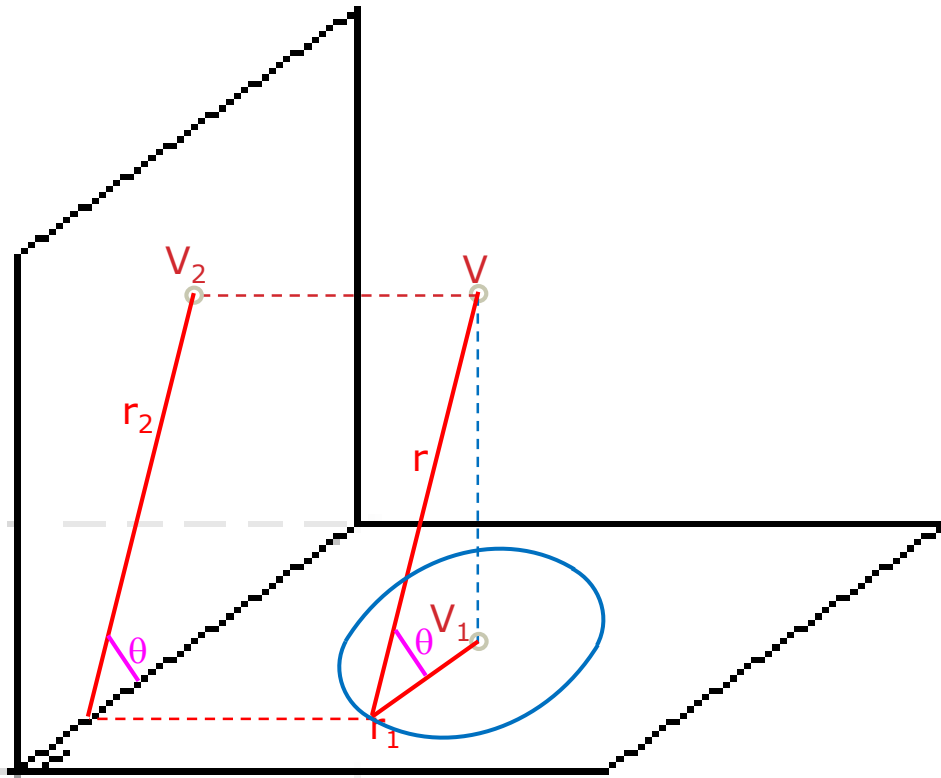

Construction of angles II

- Construction of lines and planes that form a certain angle θ with the horizontal plane and passes through point V.

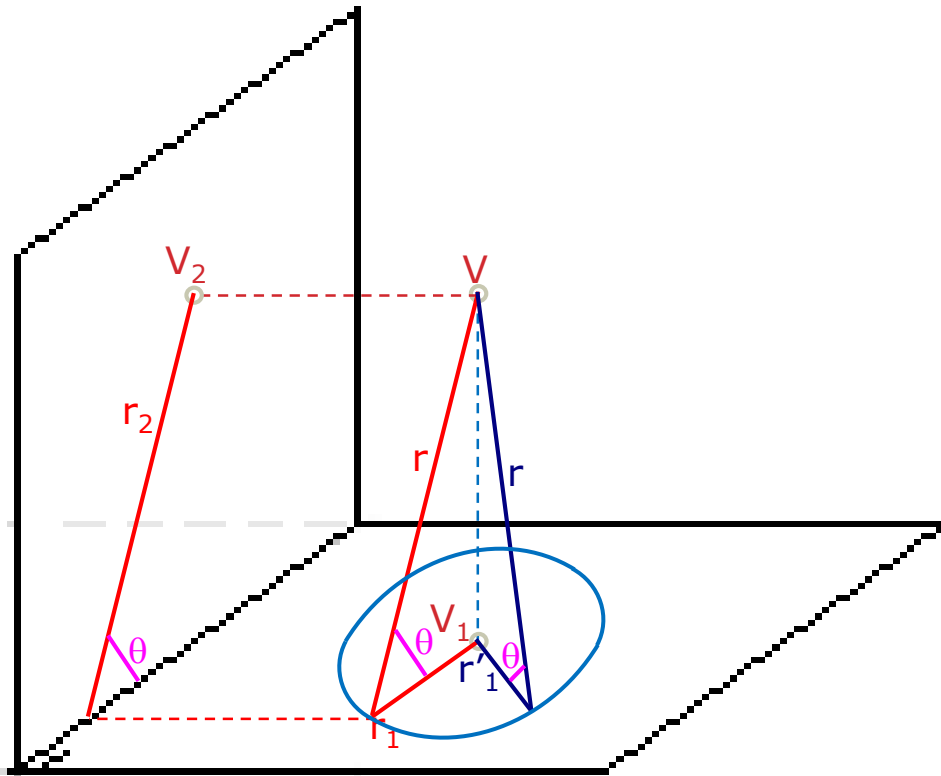

Construction of angles II

- Construction of lines and planes that form a certain angle θ with the horizontal plane and passes through point V.

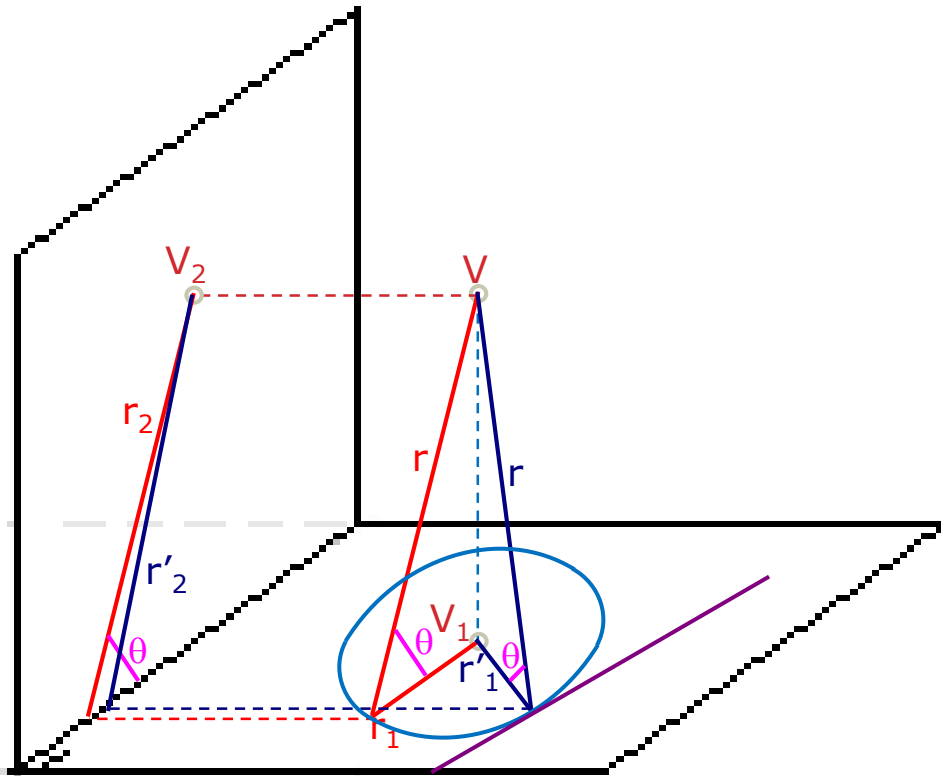

Construction of angles II

- Construction of lines and planes that form a certain angle θ with the horizontal plane and passes through point V.

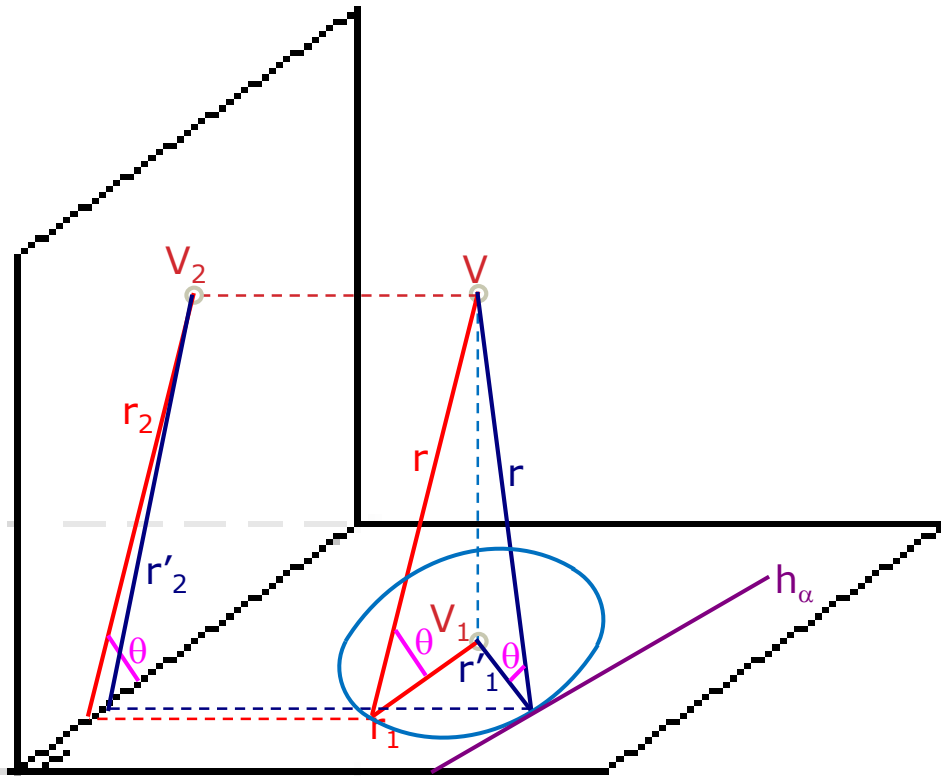

Construction of angles II

- Construction of lines and planes that form a certain angle θ with the horizontal plane and passes through point V.

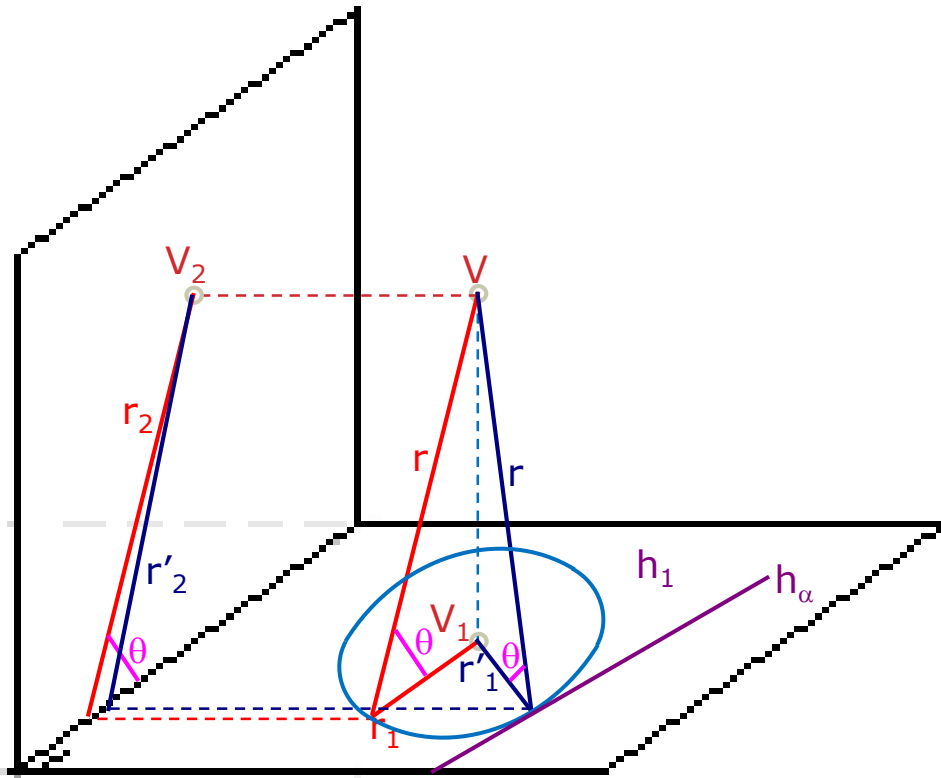

Construction of angles II

- Construction of lines and planes that form a certain angle θ with the horizontal plane and passes through point V.

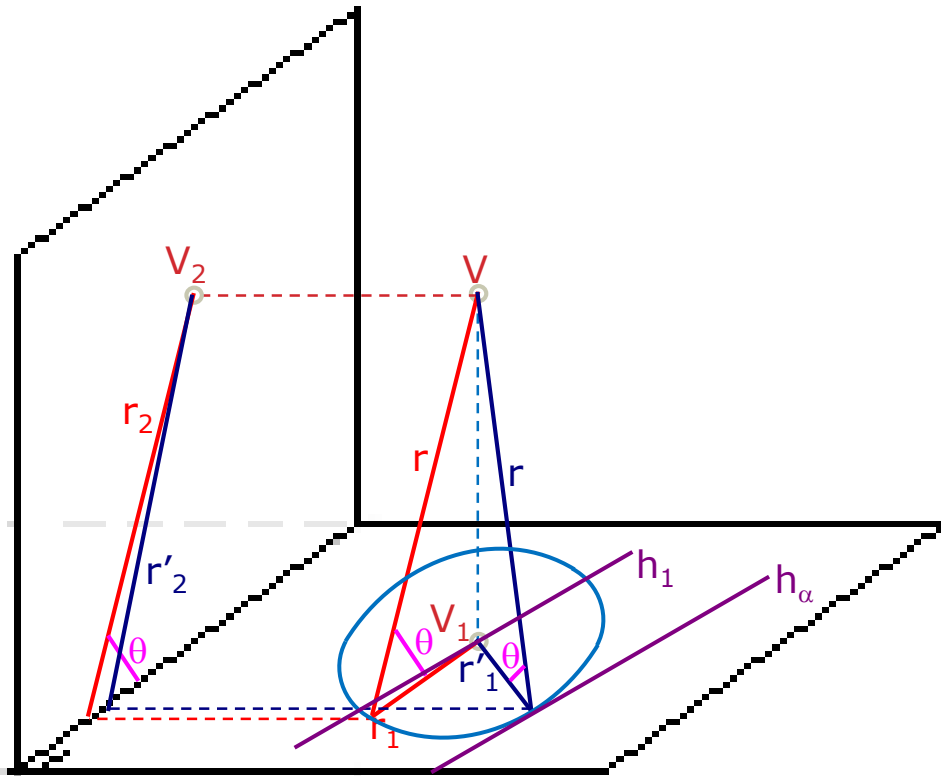

Construction of angles II

- Construction of lines and planes that form a certain angle θ with the horizontal plane and passes through point V.

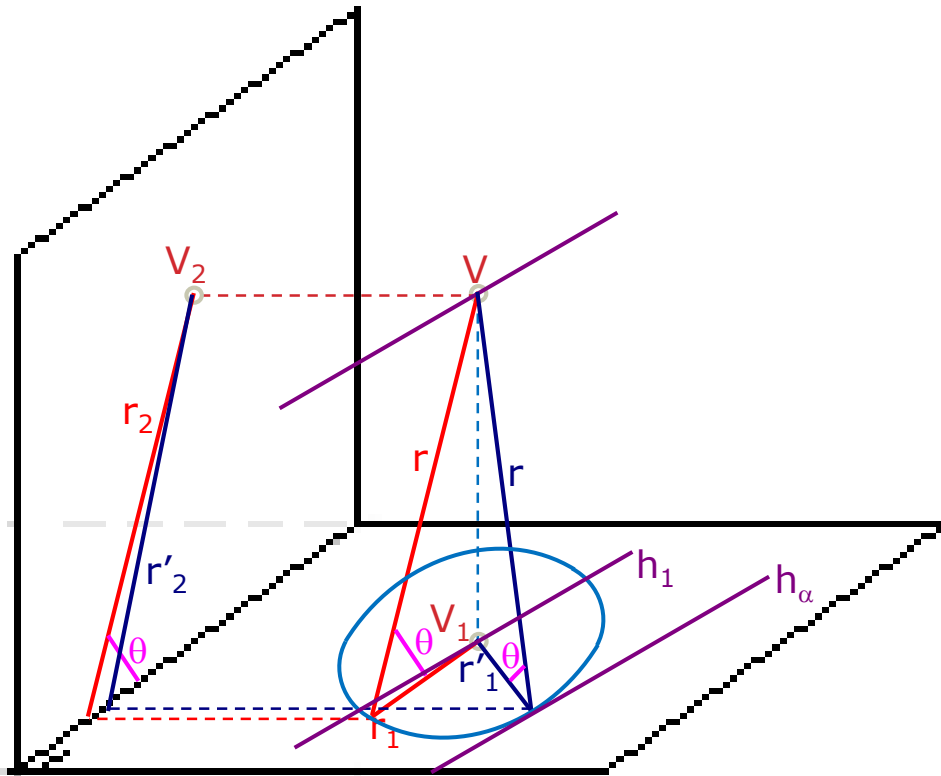

Construction of angles II

- Construction of lines and planes that form a certain angle θ with the horizontal plane and passes through point V.

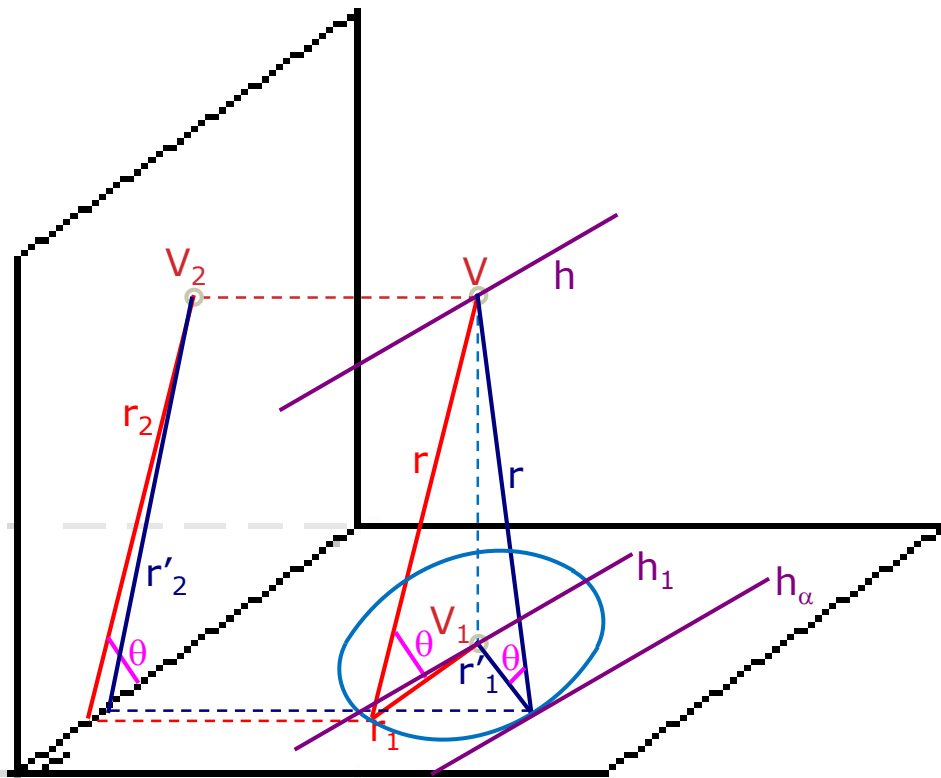

Construction of angles II

- Construction of lines and planes that form a certain angle θ with the horizontal plane and passes through point V.

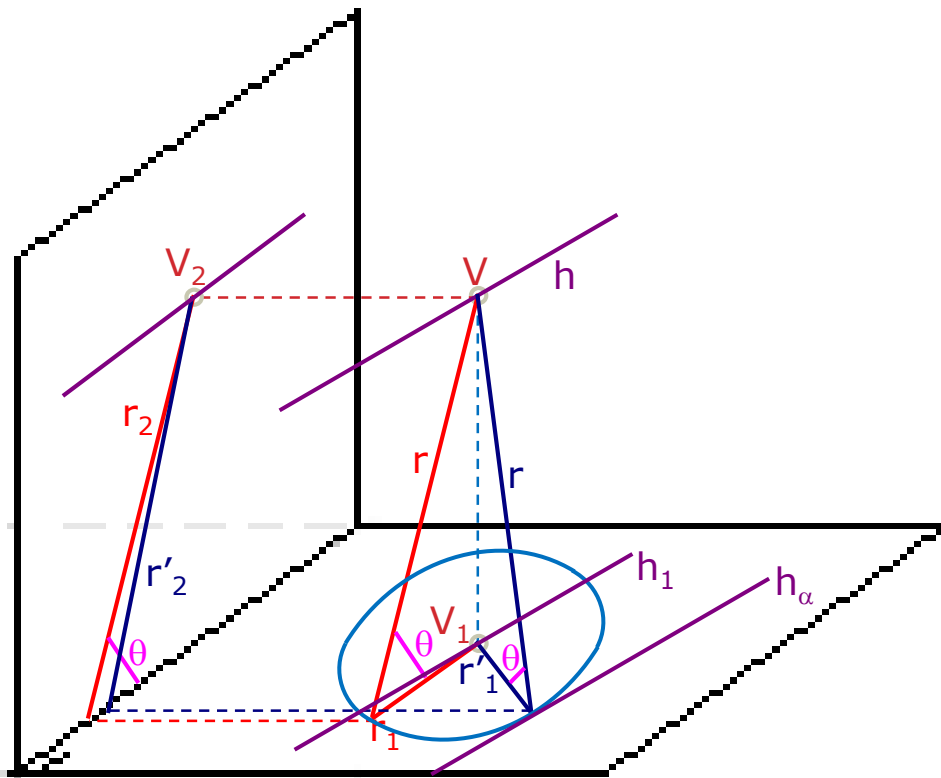

Construction of angles II

- Construction of lines and planes that form a certain angle θ with the horizontal plane and passes through point V.

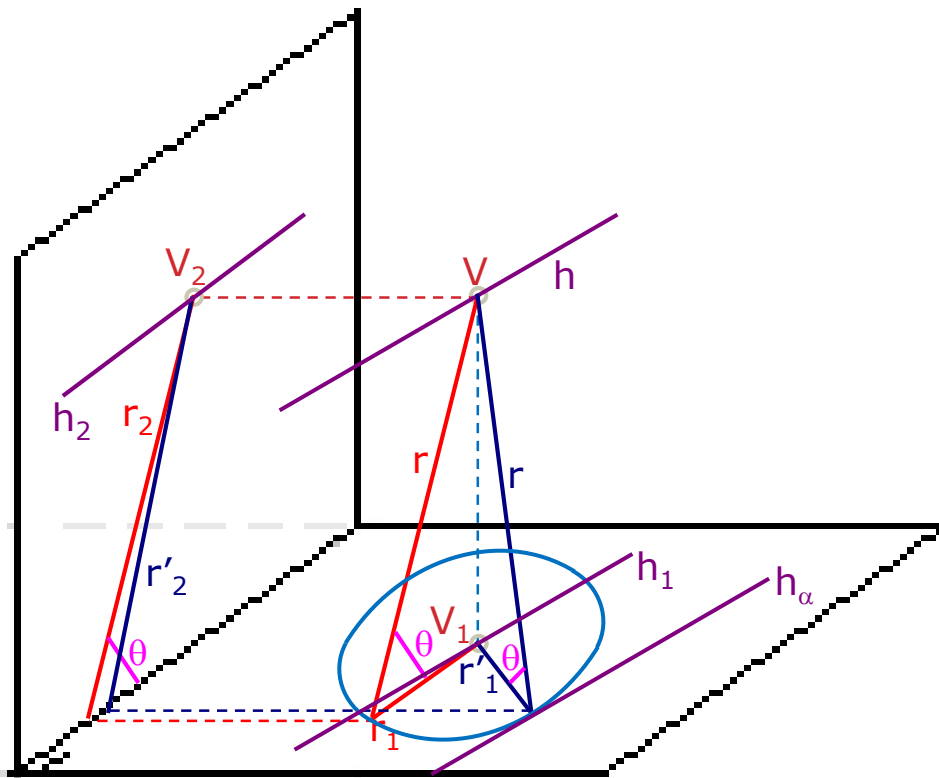

Construction of angles II

- Construction of lines and planes that form a certain angle θ with the horizontal plane and passes through point V.

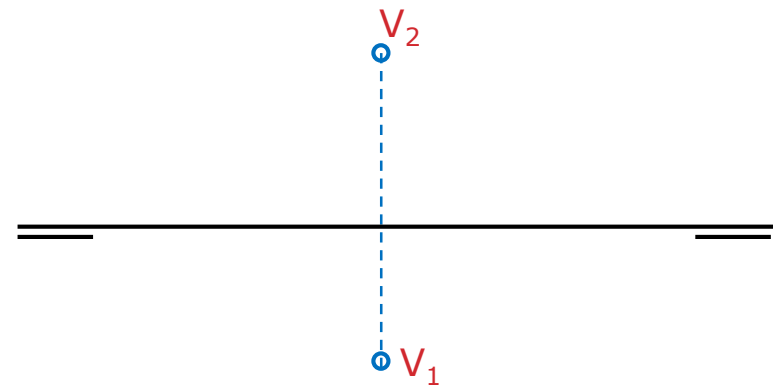
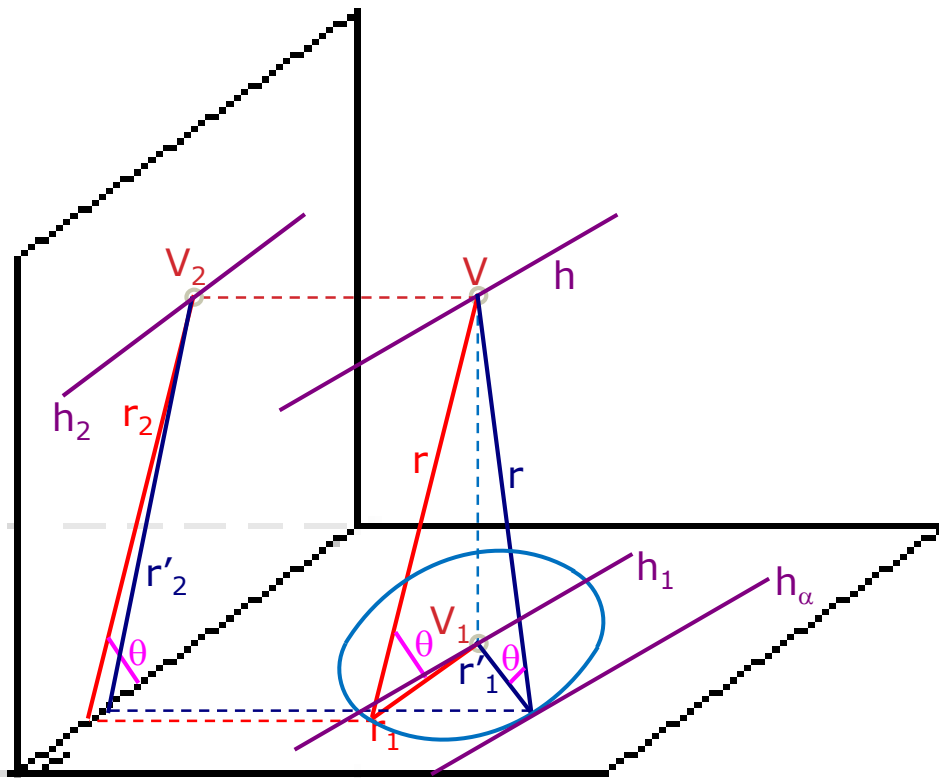

Construction of angles II

- Construction of lines and planes that form a certain angle θ with the horizontal plane and passes through point V.

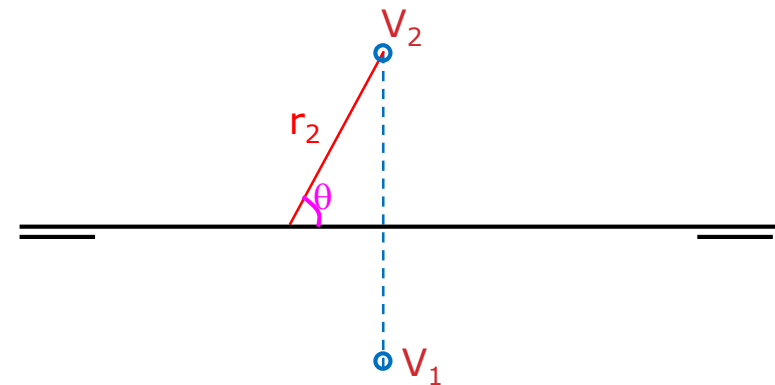
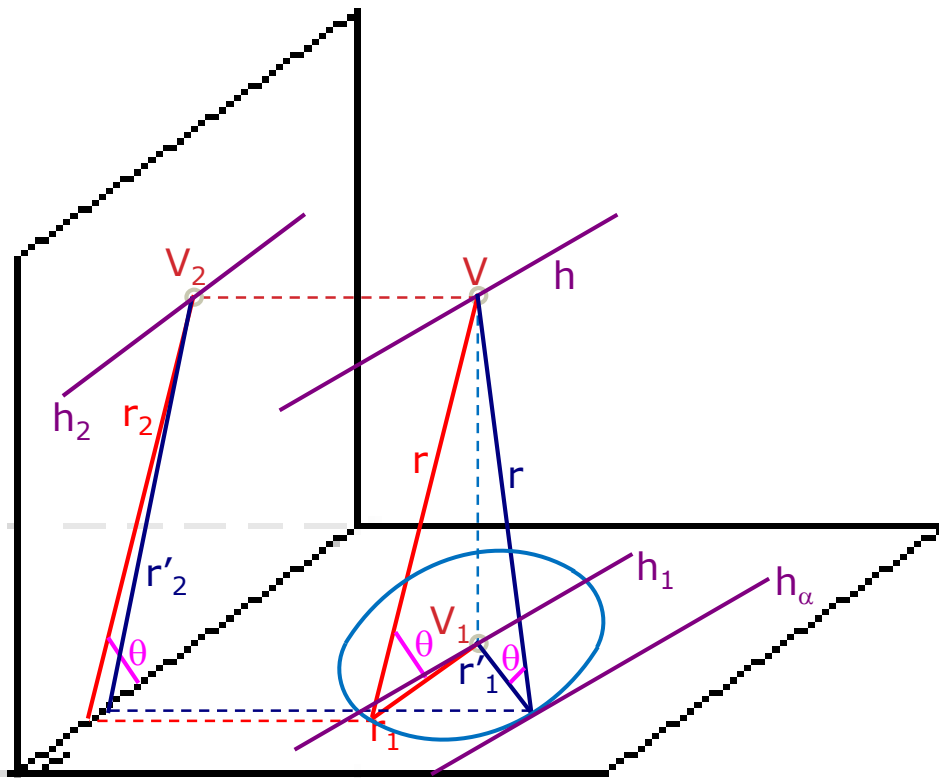

Construction of angles II

- Construction of lines and planes that form a certain angle θ with the horizontal plane and passes through point V.

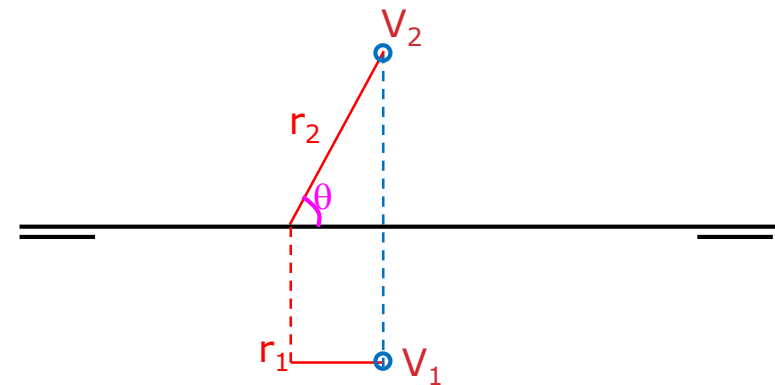
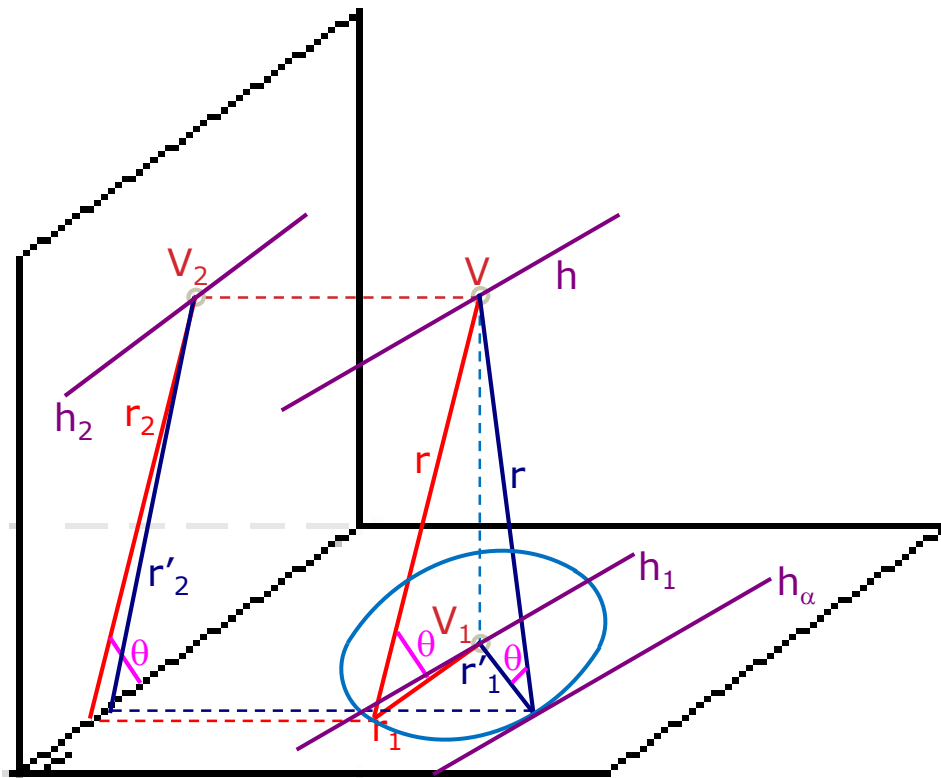

Construction of angles II

- Construction of lines and planes that form a certain angle θ with the horizontal plane and passes through point V.

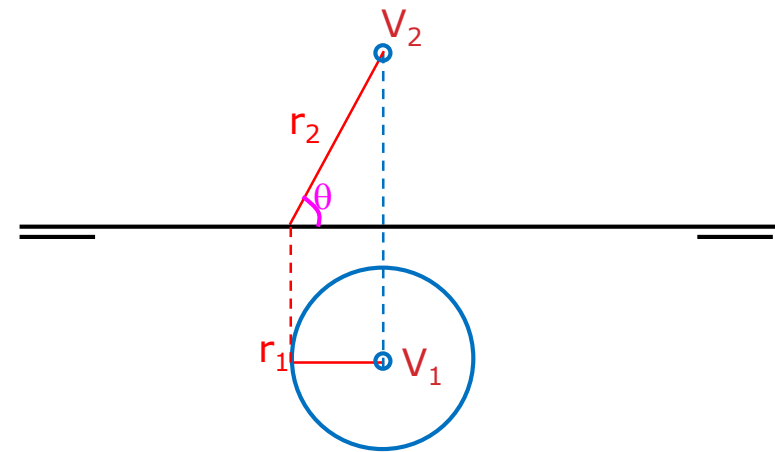
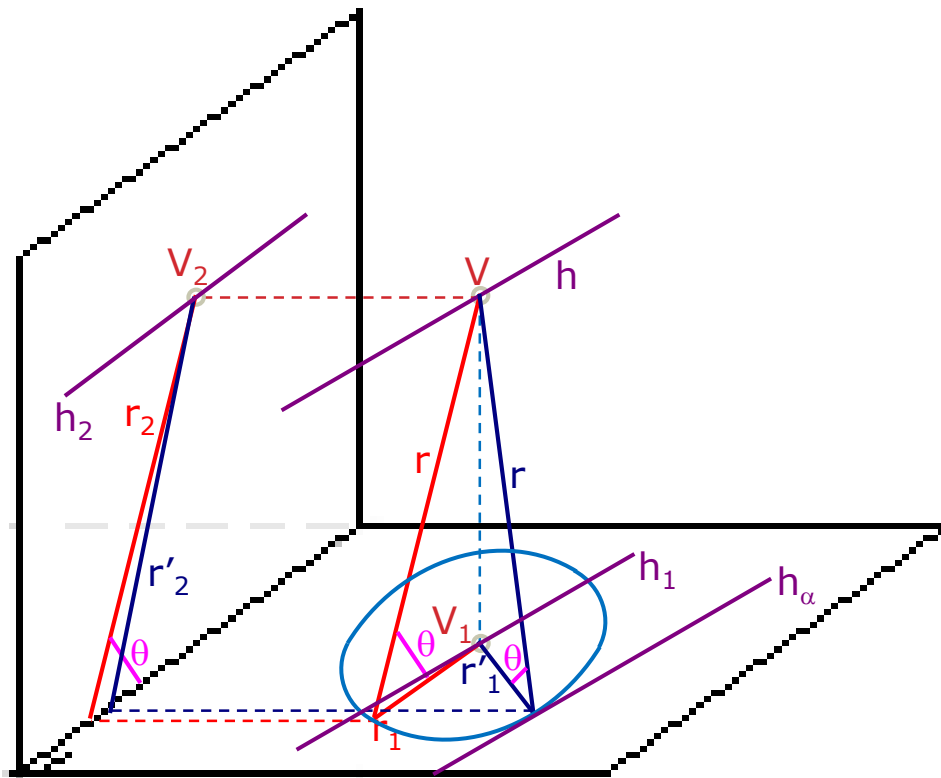

Construction of angles II

- Construction of lines and planes that form a certain angle θ with the horizontal plane and passes through point V.

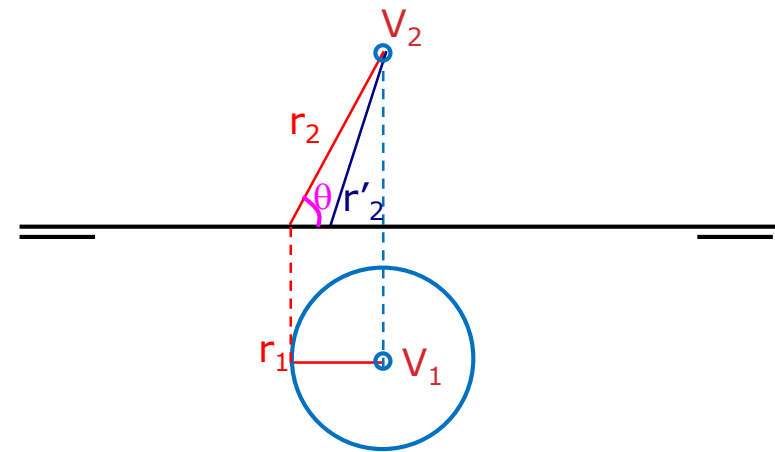
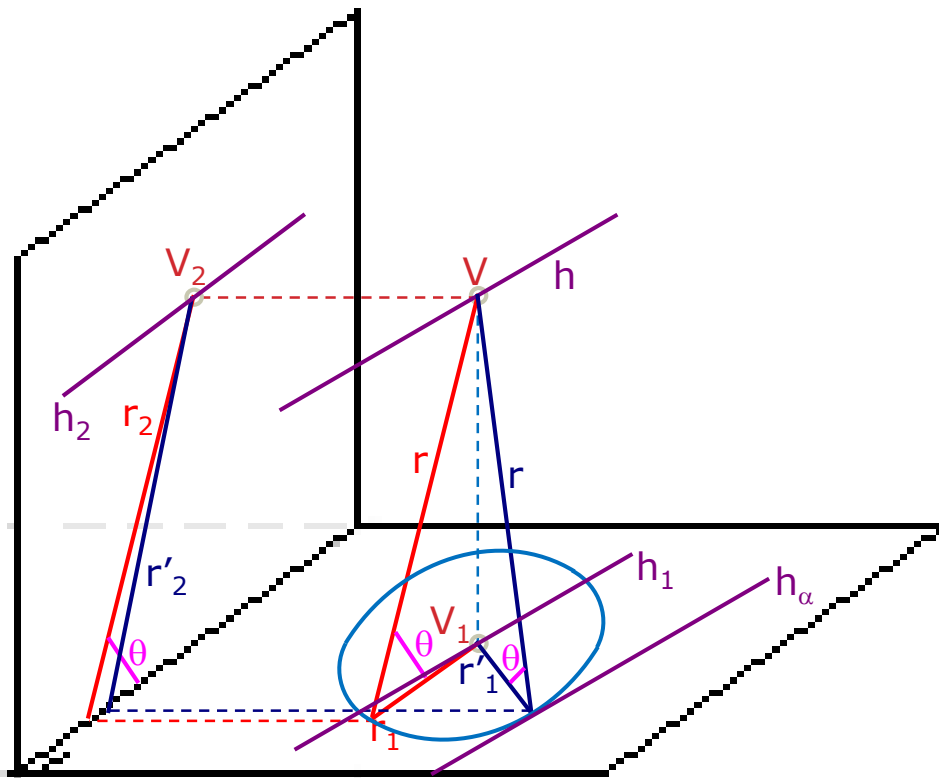

Construction of angles II

- Construction of lines and planes that form a certain angle θ with the horizontal plane and passes through point V.

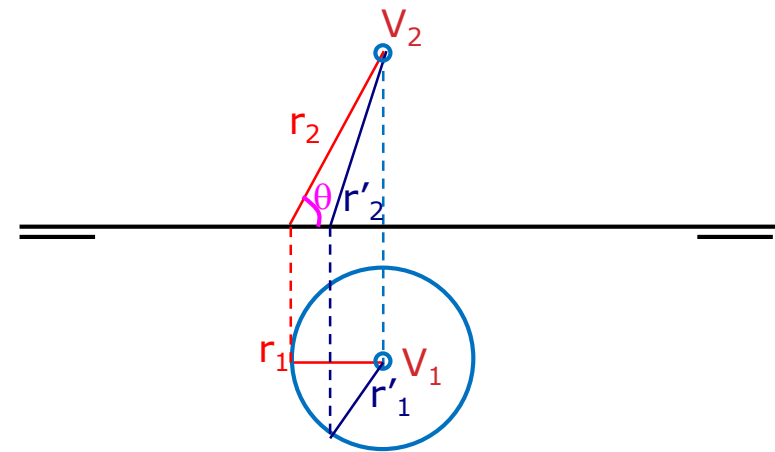
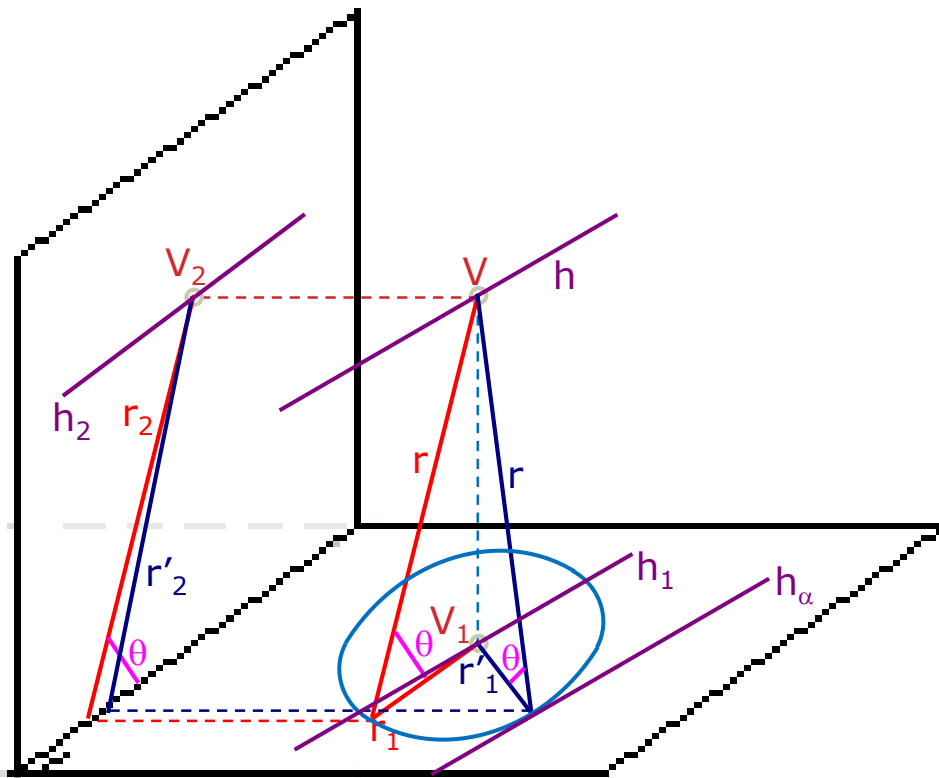

Construction of angles II

- Construction of lines and planes that form a certain angle θ with the horizontal plane and passes through point V.

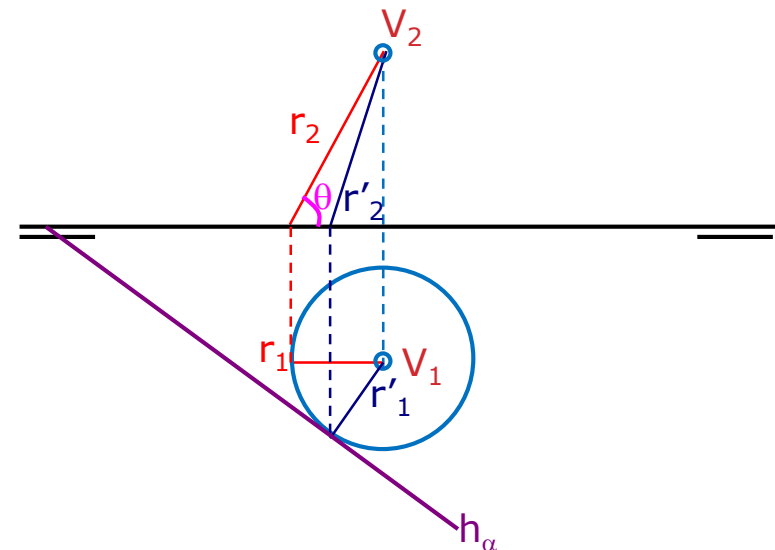
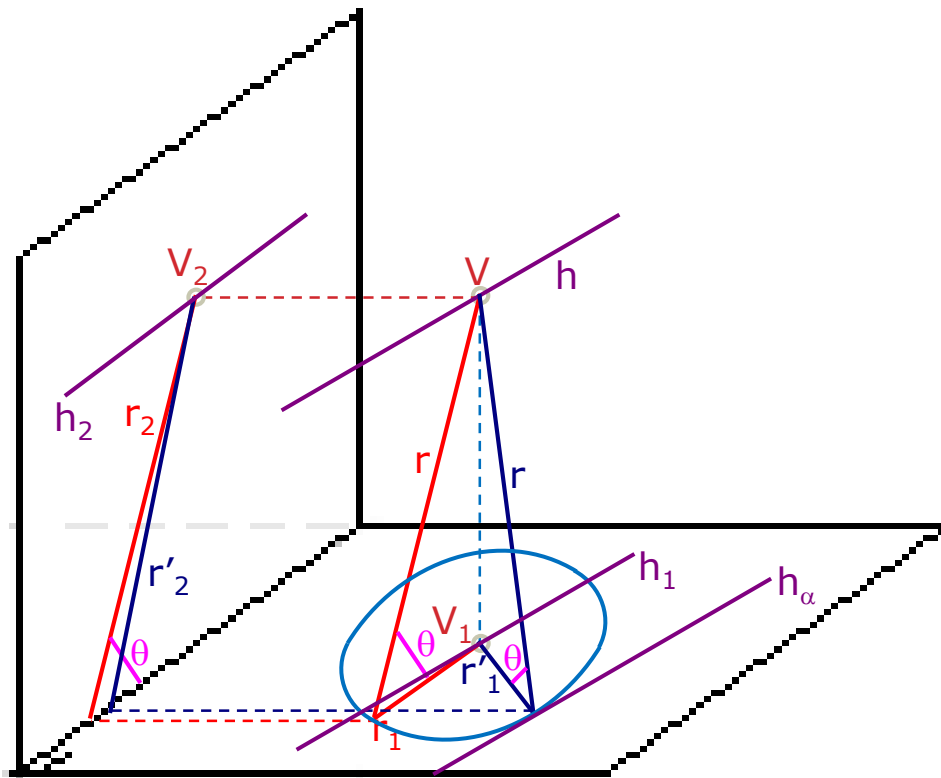

Construction of angles II

- Construction of lines and planes that form a certain angle θ with the horizontal plane and passes through point V.

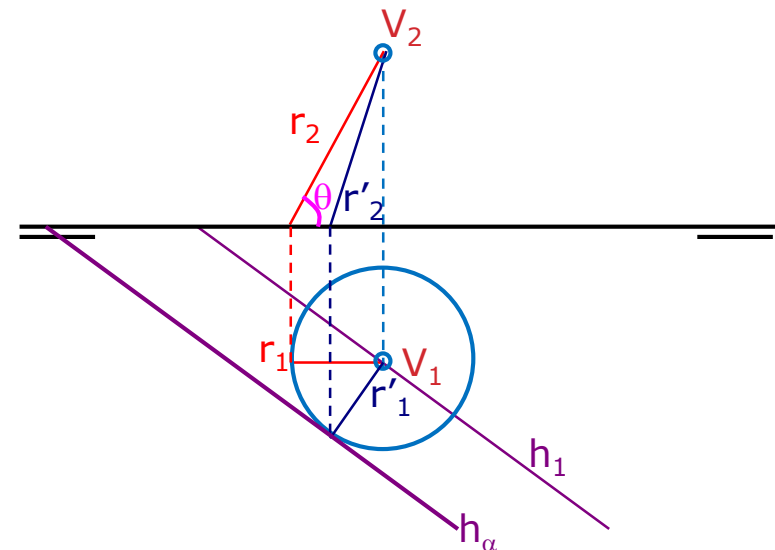
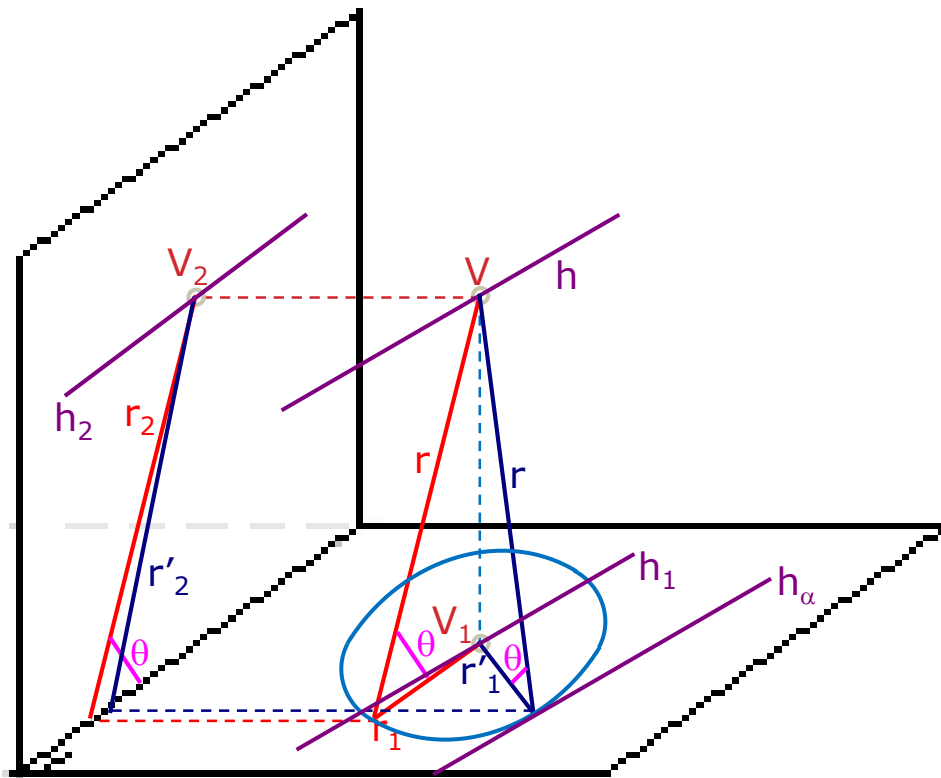

Construction of angles II

- Construction of lines and planes that form a certain angle θ with the horizontal plane and passes through point V.

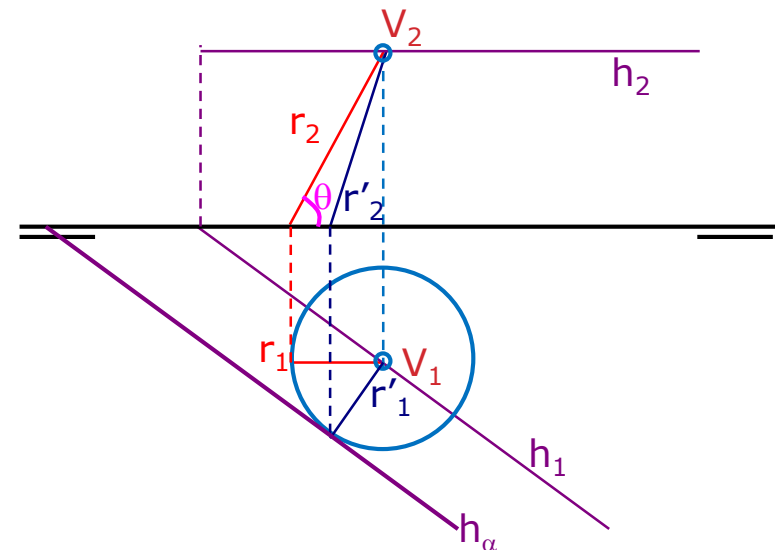
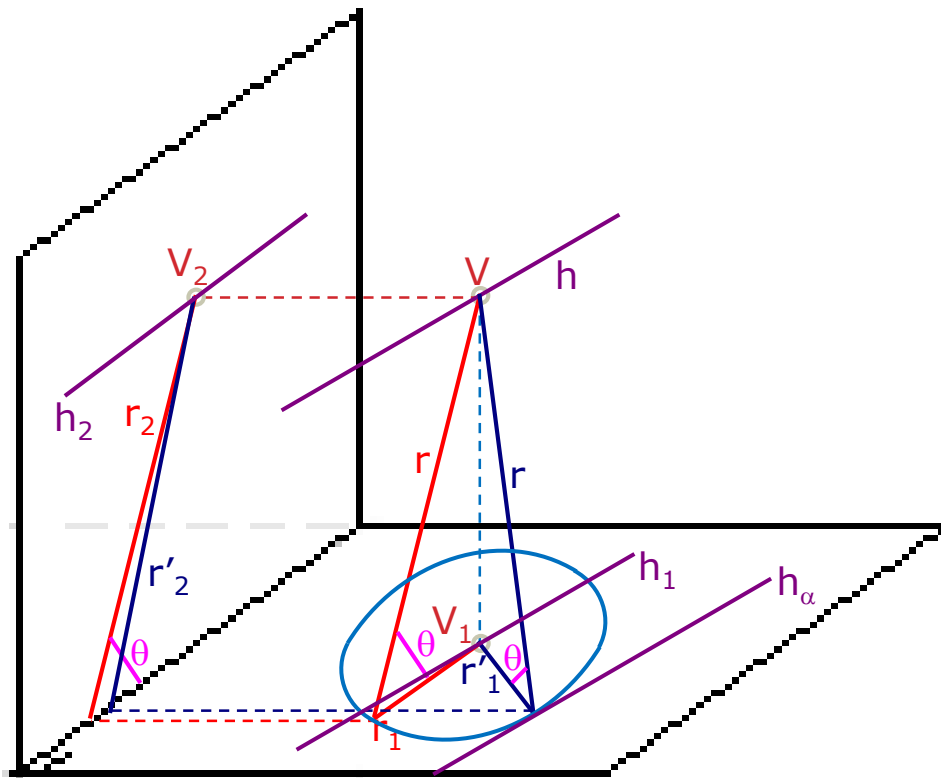

Construction of angles II

- Construction of lines and planes that form a certain angle θ with the horizontal plane and passes through point V.

