

## Tema 1: Introducción

# Sistemas Digitales Basados en Microprocesadores

Universidad Carlos III de Madrid

Dpto. Tecnología Electrónica

# Índice

- 1- Motivación y Contexto
- 2 - Presentación de la Asignatura
  - Estructura
  - Metodología
  - Evaluación
  - Prácticas
  - Profesorado
  - Planificación de la Asignatura
- 3 - Medios Materiales
  - Microprocesadores a utilizar y porqué ARM
  - Características Generales del Chip ARM
  - Sistema de Desarrollo y Prácticas
  - Bibliografía y Recursos
- 4 - Introducción Histórica – Ley de Moore

# 1 - Motivación y contexto

# Motivación

A problem has been detected and windows has been shut down to prevent damage to your computer.

The problem seems to be caused by the following file: SPCMDCON.SYS

PAGE\_FAULT\_IN\_NONPAGED\_AREA

If this is the first time you've seen this stop error screen, restart your computer. If this screen appears again, follow these steps:

Check to make sure any new hardware or software is properly installed. If this is a new installation, ask your hardware or software manufacturer for any windows updates you might need.

If problems continue, disable or remove new hardware or software. Disable BIOS memory options such as Memory Remapping. If you need to use Safe Mode to remove or disable hardware, press F8 to select Advanced Startup options and select Safe Mode.

Technical information:

\*\*\* STOP: 0x00000050

\*\*\* SPCMDCON.SYS - Aug 11 2011 10:10:10

**Gestión Incorrecta de los Recursos**  
**(tanto a nivel de aplicación,**  
**como de Sistema Operativo)**

**Desconocimiento de los Recursos Internos**

Time	Destination	Flight	Status	Gate
08:30	Belfast	EZY753	Gate opens	08:45
08:30	Madrid	EZY5477	Gate opens	08:45
08:30	Geneva	BE973	Gate opens	08:45
08:40	Montego Bay	V8065	Gate opens	08:25
13:55	Milan-Malpensa	EZY5295	Gate opens	13:10
14:00	Budapest	EZY5443	Gate opens	13:15
14:00	Fluorobentura	TCX432K	Gate opens	12:45
14:15	Riga	BT652	Gate opens	13:15
14:15	Barcelona	BE7325	Gate opens	13:50
14:15	Barcelona	TCX886K	Gate opens	13:40
14:40	Salzburg	Z3238	Gate opens	14:00
14:40	Arcade	BE7294	Gate opens	13:45
14:40	Abendorn	MON5246	Gate opens	14:00
14:45	Sofia	BE904	Gate opens	14:05
14:45	Norway	FR9853	Gate opens	14:15
14:50	Cork	FR1183	Gate opens	14:30
15:00	Shannon	BE911	Gate opens	14:30
15:15	Guernsey	EZY5307	Gate opens	14:30
15:15	Marrakech	GR805	Gate opens	14:45
15:30	Guernsey	FR9229	Gate opens	14:45
15:30	Girona	MON2274	Gate opens	14:30
15:30	Sofia	EZY5455	Gate opens	15:10
15:55	Lisbon	BE466	Gate opens	15:25
16:05	Newcastle	EZY5257	Gate opens	15:25
16:10	Rome	EZY5265	Gate opens	15:25
16:15	Venice	TP349	Gate opens	15:40
16:25	Funchal	BE970	Gate opens	15:40
16:25	Belfast City	BE970	Gate opens	15:40
16:30	Geneva	BD7661	Gate opens	15:30

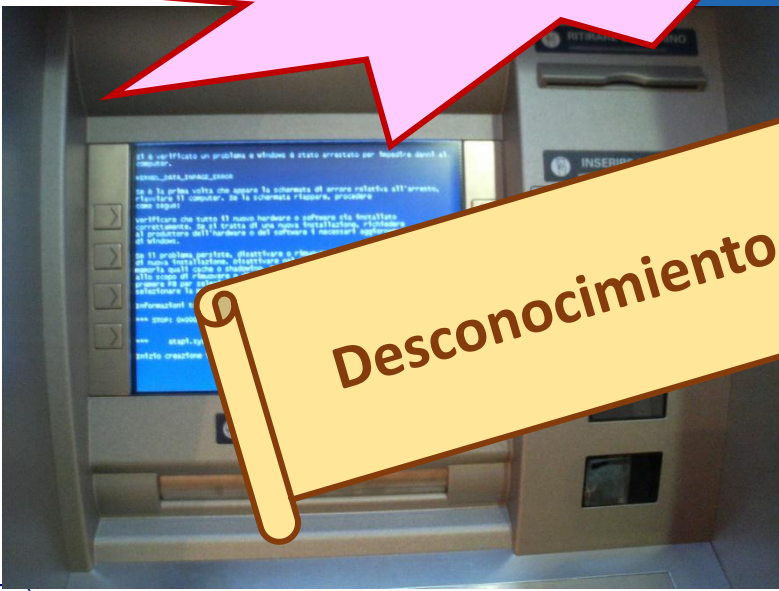

11:31 PM

35

Add to Portfolio

**Sorry!**

Activity StockManager (in application StockManager) is not responding.

Force close      Wait

# Contexto

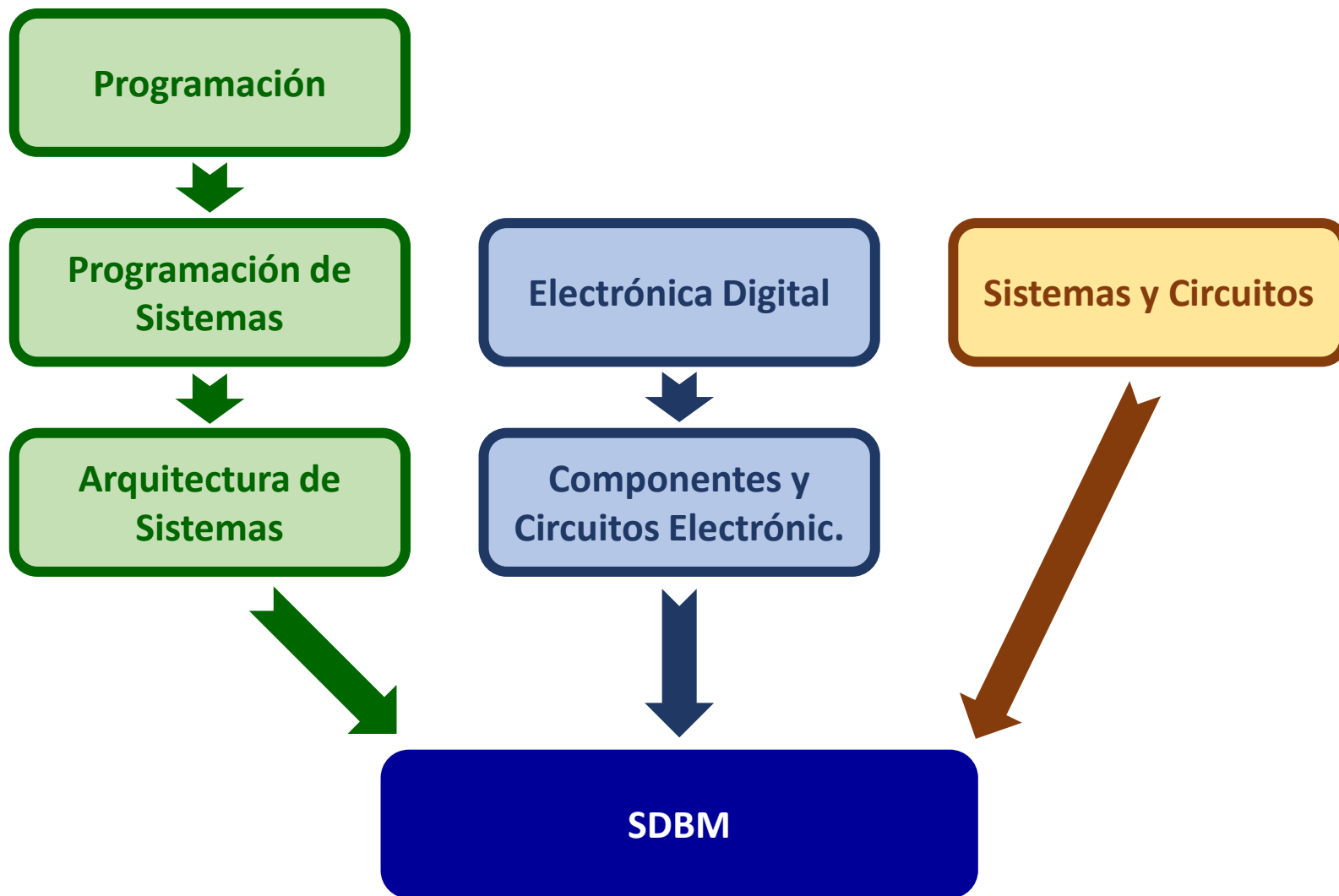

## 2 - Presentación de la asignatura

# Presentación de la Asignatura

- Asignatura Obligatoria de 6 ECTS
  - 24 Sesiones de Teoría y Teórico-Prácticas
  - 6 Sesiones de 2h de Prácticas de Laboratorio (Cambio respecto al curso pasado)
  - Centrada en los Fundamentos Básicos, pero con proyección a Desarrollo de Sistemas
- Objetivos a Cubrir:
  - Conceptos Básicos
    - Arquitectura Interna de una CPU
    - Programación de una CPU a Bajo Nivel
    - Conexionado con Sistemas de Memorias
    - Sistemas Básicos de Entrada / Salida
  - Conceptos Avanzados
    - Arquitecturas Von Neumann y Harvard
    - Arquitecturas CISC y RISC
    - Programación en medio-alto nivel
      - Mecanismos Avanzados de Programación y Efectos de los Compiladores
    - Sistemas Avanzados de Gestión de Memoria
    - Sistemas Avanzados de Entrada / Salida

# Estructura

1. Introducción de la Asignatura (2h)
2. Microprocesadores y Microcontroladores (2h)
3. Arquitectura Interna de una CPU (4h)
4. Lenguaje Ensamblador (2h) + Ejercicios (2h)

5. Entorno de Desarrollo (2h)
6. Pines de Entrada/Salida (2h)
7. Conversión Analógica (2h)
8. Interrupciones (2h)
9. Temporización (2h)
10. Trabajando con Memoria (2h)
11. Comunicación I2C (2h)
12. Comunicación SPI (2h)
13. Funciones Especiales (2h)
14. Diseño de Soluciones y Problemas de Examen (4h)

**Práctica 1: Entorno de Desarrollo (2h)**

**Práctica 2: GPIO (2h)**

**Práctica 3: IRQ, EXTI y ADC (2h)**

**Práctica 4: Timers (2h)**

**Práctica 5: USART (2h)**

**Práctica 6: Sistema Completo (2h)**

(2h)  
(2h)



# Metodología

- **Aprendizaje a través de la práctica:**

- Ejemplos mostrados y ejecutados en clase
- Ejercicios propuestos y realizados por los alumnos en casa
- Prácticas de Laboratorio

Distribución de Horas de la Asignatura

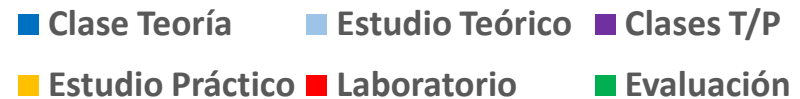
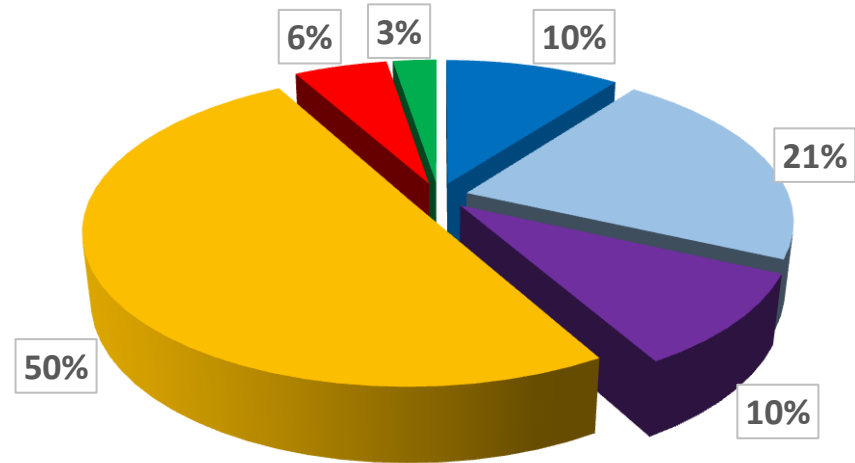

- **Flujo Docente:**



# Evaluación

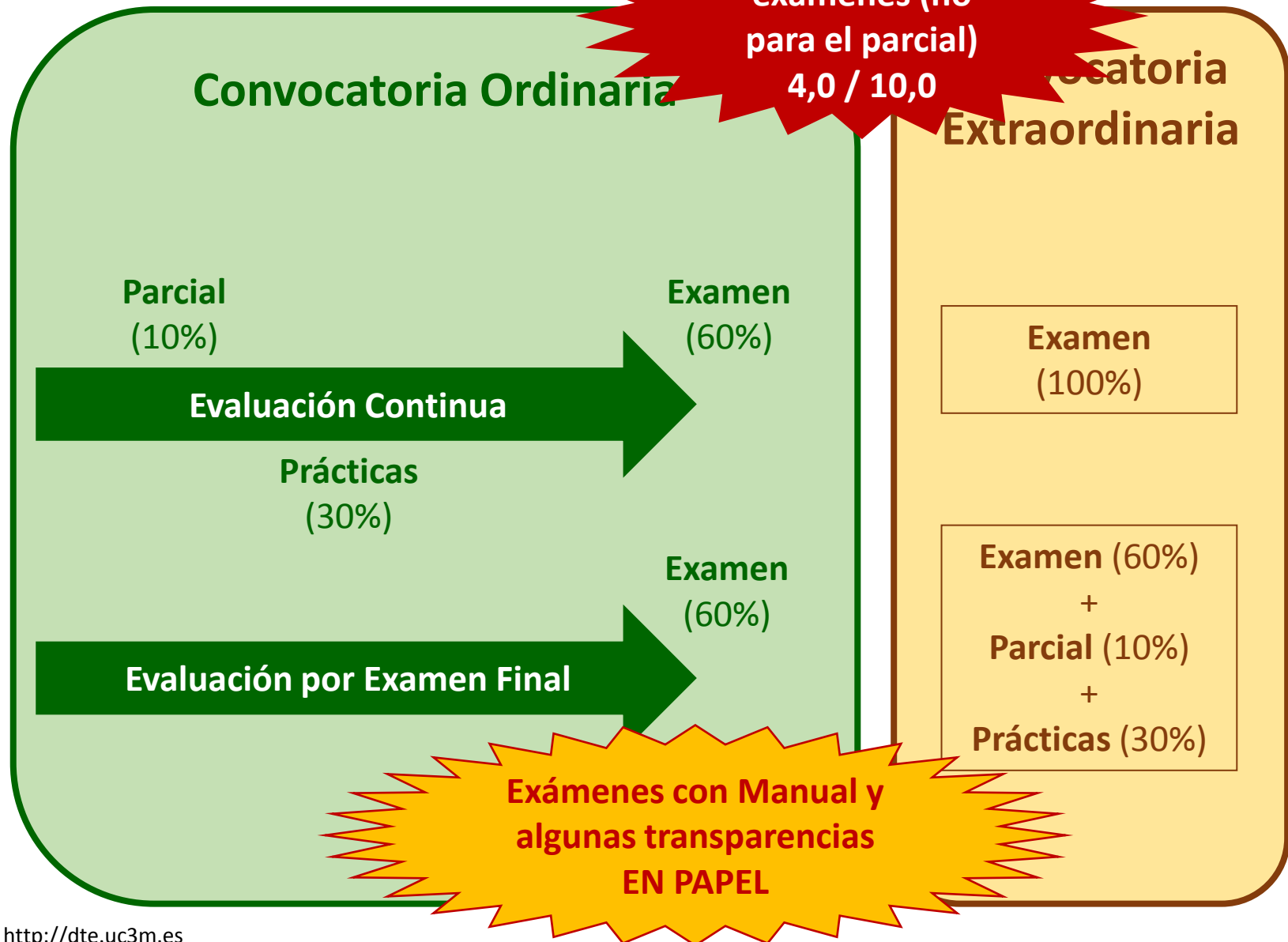

# Prácticas

- 6 Prácticas en sesiones de 2 horas de Laboratorio
  - Prácticas Guiadas pero de Desarrollo
  - Grupos de 2 personas
    - **Los grupos se crearán en la primera semana, a través de Aula Global, para posteriormente poder entregar el material. Plazo máximo de inscripción: 6 de febrero**
- Método de Trabajo:
  - Antes de la Sesión en Laboratorio
    - El grupo analiza el enunciado y resuelve la práctica
    - Se le da un cuestionario para que lo rellene, que incluya el diagrama de flujo de la solución y la primera versión del código
    - **Se entrega por Aula Global por Turnitin antes de que empiece el laboratorio**
  - Durante la Sesión de Laboratorio
    - El profesor entrega al grupo una serie de modificaciones a realizar en la práctica
    - El grupo realiza y prueba las modificaciones que sean necesarias
    - El profesor evalúa el correcto funcionamiento de las distintas partes de la práctica original (8 puntos sobre 10) y la modificación solicitada (2 puntos sobre 10), **aunque esto no es fijo y ya os avisaremos de la división definitiva de puntos**
    - **Se entrega en Aula Global por Turnitin la versión final del proyecto hasta 15 minutos después de acabar el laboratorio**

La ausencia en alguna de las prácticas elimina la Evaluación Continua

Asistencia = Firma + Entregas

# Profesorado

Profesor	Grupo (Tipo)	Despacho	Horario Tutorías
<b>Elena Romero</b> <a href="mailto:elena.romero@uc3m.es">elena.romero@uc3m.es</a>	<b>Teoría y Laboratorio</b>	<b>1.2.F.05</b>	<b>A concretar</b>
<b>José Enrique Suárez</b> <a href="mailto:enrique.suarez@educa.madrid.org">enrique.suarez@educa.madrid.org</a>	<b>Teoría y Laboratorio</b>		<b>X 19-20</b> <b>Previa</b> <b>petición de</b> <b>cita por</b> <b>correo</b>

# Planificación de la Asignatura para GIT y GISCS

CRONOGRAMA DE LA ASIGNATURA				
Semana	Sesión	Fecha	Descripción del Contenido	Profesor
1		28-ene.	Tema 1: Introducción	JE
		30/31/ene	Tema 2: Microprocesadores y Microcontroladores	G
		30/31/ene	Tema 3: Arquitectura Interna	G
2		4-feb.	Tema 3: Arquitectura Interna	E
		06/07/feb.	Tema 4: Ensamblador	G
		06/07feb.	Tema 4: Ensamblador + Ejercicios	G
3		11-feb.	Tema 5: Entorno de Desarrollo	E
		13/14/feb.	P1: Entorno de Desarrollo	Lab
4		18-feb.	Examen Parcial	Ambos
		20/21/feb.	Tema 6: GPIO y AFs	G
5		25-feb.	Tema 7: ADC y DAC	JE
		27/28/feb.	P2: GPIO	Lab
6		4-mar.	Tema 8: IRQs y EXTI	JE
		06/07/mar.	Tema 8: Ejercicios con IRQs y ADC	G
7		11-mar.	Tema 9: Timers	JE
		13/14/mar.	P3: EXTI y ADC	Lab
8		18-mar.	Tema 9: Timers	JE
		20/21/mar.	Tema 9: Ejercicios de Timers	G
9		25-mar.	Tema 10: USART	E
		27/28/mar.	P4: Timers	Lab
10		1-abr.	Tema 10: USART	E
		03/04/abr.	Tema 10: Ejercicios de USART	G
11		8-abr.	Tema 11: SPI / I2C	E
		8-abr.	Tema 11: SPI / I2C + Ejercicios	E
		10/11/abr.	P5: USART	Lab
12		24/25/abr.	P6: Práctica Final de integración	Lab
13		29-abr.	Problemas de Examen	JE
14		6-may.	Problemas de Examen	E
		08/09/may.	Problemas de Examen	G

# 3 - Medios Materiales

# Medios Materiales

- Motivación:
  - Nivel tecnológico
    - Última generación de Microprocesadores de bajo coste orientado a equipos embebidos.
  - Actualidad
    - SO: Symbian, Linux, Windows CE
    - Equipos: Teléfonos, PDAs, PCs-embarcados, etc...
  - Trabajo
    - Micro muy demandado en el mercado.
- Microprocesador a estudiar:
  - CPU: ARM Cortex M3
  - Microcontrolador: STM32L152RB
  - Placa de Desarrollo: STM32L-Discovery
  - IDE: Keil uVision 5
  - Lenguaje: C



Hardware requirements:

- USB cable type A to mini-B
- computer with Windows 2000, XP, Vista or 7

Development toolchain:

- Altium TASKING VX-Toolset,
- Atollic TrueSTUDIO
- IAR EWARM
- Keil MDK-ARM

# ¿Por qué ARM?

- En 2011, los procesadores ARM aparecen en la mayoría de *smartphones* y tabletas del mercado
- Microsoft introdujo con Windows RT una versión que incluye un modo compatible con los procesadores de ARM
- Un primer producto de éxito (1993), fué la PDA Newton de Apple
- Otro de más impacto (2001), el iPod de Apple
- ARM significa Advanced RISC Machine
- Utiliza arquitectura RISC (*Reduced Instruction Set Computer*)
- Los procesadores ARM se han diseñado para usarse en aplicaciones de bajo consumo, alimentados con batería

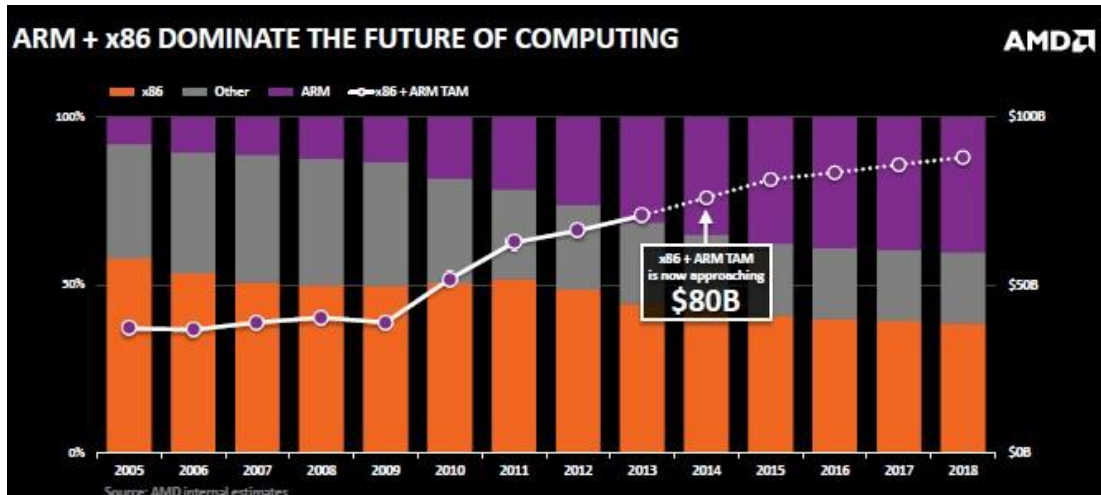

# ARM



# Algunos equipos con CPU de ARM



Toshiba PD RM4



Lexmark Z52  
Color Jetprinter



InCard MoKard



BOSCH



SONICblue RIO Digital Audio



EXFO FTB-100



Creative Nomad  
Jukebox



Intel Pocket Concert



Wherify GPS  
watch



Galleo Communicator



D-Link Wireless LAN



Zoom Cable  
Modem



Alcatel ADSL  
Modem



Efficient Networks  
ADSL Router



Alcatel Speed  
Touch Wireless



G.Mate Yopy



Nokia Communicator



Compaq iPAQ



Ericsson  
T68



Trium  
Eclipse



Sendo Z100



Nokia 8310

# Fabricantes de ARM

- Los procesadores ARM no se venden como un *chip*, sino como una licencia de hardware IP (*Intellectual Property*)
- El comprador añade sus propios periféricos y fabrica los *chips*
- Algunos fabricantes de sistemas basados en ARM:



# Microcontrolador STM32L152RBT6

STMicroelectronics

Ultralow power ARM-based 32-bit MCU with up to 128 KB Flash, RTC, LCD, USB, USART, I2C, SPI, timers, ADC, DAC, comparators

## Device family

**STM32** = ARM-based 32-bit microcontroller

## Product type

**L** = Low power

## Device subfamily

151: Devices without LCD

**152** = Devices with LCD

## Pin count

C = 48 pins

**R** = 64 pins

V = 100 pins

## Flash memory size

6 = 32 Kbytes of Flash memory

8 = 64 Kbytes of Flash memory

**B** = 128 Kbytes of Flash memory

## Package

H = BGA

**T** = LQFP

U = UFQFPN

## Temperature range

**6** = Industrial temperature range, -40 to 85 °C

## Features

### ■ Operating conditions

- Operating power supply range: 1.65 V to 3.6 V (without BOR) or 1.8 V to 3.6 V (with BOR option)
- Temperature range: -40 to 85 °C

### ■ Low power features

- 4 modes: Sleep, Low-power run (9 µA at 32 kHz), Low-power sleep (4.4 µA), Stop with RTC (1.45 µA), Stop (570 nA), Standby (300 nA)
- Dynamic core voltage scaling down to 233 µA/MHz
- Ultralow leakage per I/O: 50 nA
- Fast wakeup from Stop: 8 µs
- Three wakeup pins

### ■ Core: ARM 32-bit Cortex™-M3 CPU

- 32 MHz maximum frequency, 33.3 DMIPS peak (Dhrystone 2.1)
- Memory protection unit

### ■ Reset and supply management

- Low power, ultrasafe BOR (brownout reset) with 5 selectable thresholds
- Ultralow power POR/PDR
- Programmable voltage detector (PVD)

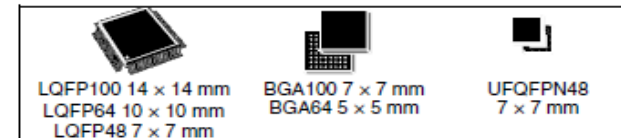

- Up to 16 Kbyte of RAM

### ■ Up to 83 fast I/Os (73 of which are 5 V-tolerant) all mappable on 16 external interrupt vectors

### ■ Development support

- Serial wire debug, JTAG and trace

### ■ DMA: 7-channel DMA controller, supporting timers, ADC, SPIs, I<sup>2</sup>Cs and USARTs

### ■ LCD 8 × 40 or 4 × 44 with step-up converter

### ■ 12-bit ADC up to 1 Msps/24 channels

- Temperature sensor and internal voltage reference
- Operates down to 1.8 V

### ■ 2 × 12-bit DACs with output buffers

### ■ 2 ultralow power comparators

- Window mode and wakeup capability

### ■ 10 timers:

- 6 × 16-bit general-purpose timers, each with up to 4 IC/OC/PWM channels
- 2 × 16-bit basic timers
- 2 × watchdog timers (independent and window)

# Características del Chip STM32L152RBT6

Table 2. Ultralow power STM32L15xxx device features and peripheral counts

Peripheral		STM32L15xCx			STM32L15xRx			STM32L15xVx	
Flash - Kbytes		32	64	128	32	64	128	64	128
RAM - Kbytes		10	10	16	10	10	16	10	16
Timers	General-purpose	6			6			6	
	Basic	2			2			2	
Communication interfaces	SPI	2			2			2	
	I <sup>2</sup> C	2			2			2	
	USART	3			3			3	
	USB	1			1			1	
GPIOs		37			51			83	
12-bit synchronized ADC		1			1			1	
Number of channels		16 channels			20 channels			24 channels	
12-bit DAC		2			2			2	
Number of channels		2			2			2	
LCD (STM32L152xx Only)		4x16			4x32 8x28			4x44 8x40	
COM x SEG									
Comparator		2			2			2	
CPU frequency		32 MHz							
Operating voltage		1.8 V to 3.6 V (down to 1.65 V at power-down) with BOR option 1.65 V to 3.6 V without BOR option							
Operating temperatures		Ambient temperatures: -40 to +85 °C Junction temperature: -40 to +105 °C							
Packages		LQFP48, UFQFPN48			LQFP64, BGA64			LQFP100, BGA100	

STMicroelectronics

# Placa de Desarrollo STM32L-DISCOVERY

- La placa de desarrollo STM32L-DISCOVERY solo requiere una conexión a PC y, además del micro, incluye los siguientes elementos:
  - Mecanismo de depuración con el sistema ST-LINK/V2 integrado en la propia placa
  - Alimentación a través del cable de conexión USB a PC
  - Display LCD de 6 caracteres
  - 4 LEDs, 2 de ellos programables por el usuario
  - Dos pulsadores (User y Reset)
  - Conectores de expansión de I/O a placa externa
  - Otros elementos
- Las placas se les reparte a los alumnos (una por alumno), en uno de los siguientes dos momentos:
  - Los profesores las repartimos en clase, un día antes de dar el Tema 5 (es la recomendación, porque así se los alumnos instalan en su casa el entorno con la placa conectada e instalan los drivers)
  - El primer día de prácticas (no recomendado)
- Al dar la placa, los alumnos tienen que rellenar por duplicado (ya que los técnicos de laboratorio no se quedan con copia) el acuerdo de préstamo.
- Los alumnos tendrán que devolver la placa, igualmente, en dos momentos como mucho:
  - El día de la última práctica (recomendado)
  - El día del examen (no recomendado)



# Entorno de Desarrollo

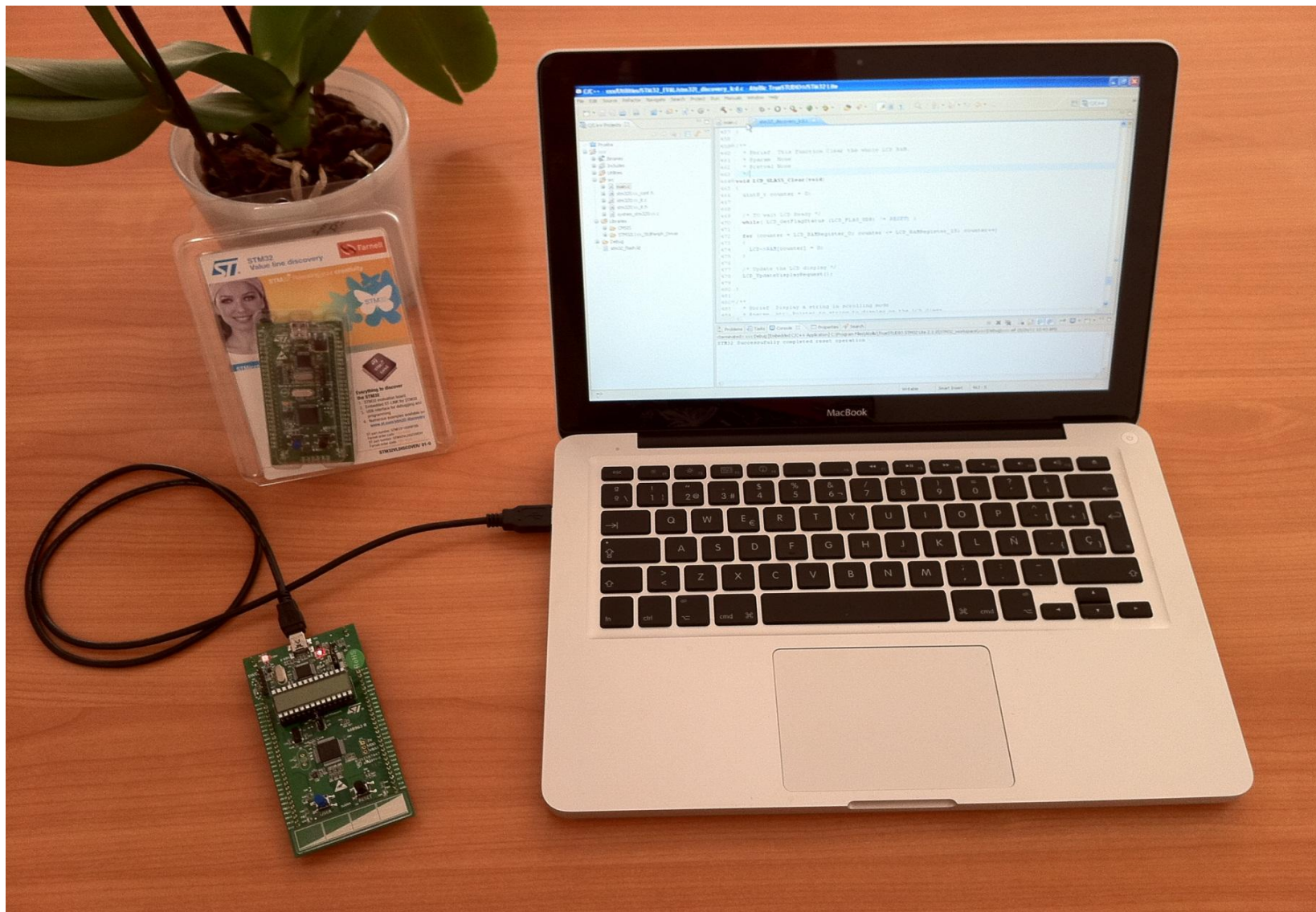

# Sistema de Desarrollo (IDE): Keil uVision 5



## MDK-ARM Version 5

**MDK Core**

- µVision IDE with Editor
- ARM C/C++ Compiler
- Pack Installer
- µVision Debugger with Trace

**Software Packs**

<b>Device</b>	<b>CMSIS</b>	<b>MDK Profes</b>
System / Startup	CMSIS-CORE	TCP/IP
Driver 1: SPI	CMSIS-DSP	Networking
Driver 2: Ethernet	CMSIS-RTOS	USB Host Sta
...		USB Device Sta
Driver n: USB		

CA\Ejercicios\_SDBM\Ejercicio 3-1\ej3\_1.uvprojx - µVision

File Edit View Project Flash Debug Peripherals Tools SVCS Window Help

Target 1

Project

- Project: ej3\_1
  - Target 1
    - Source Group 1
      - principal.c
      - Utiles\_SDM.c
      - Biblioteca\_SDM.lib
    - CMSIS
    - Device
      - startup\_stm3211xx\_md.s
      - system\_stm3211xx.c

```
principal.c
1 /** Ejemplo de uso del LCD **/
2
3 #include "Biblioteca_SDM.h"
4 #include "Utiles_SDM.h"
5
6 int main(void) {
7     Init_SDM();
8     Init_LCD();
9
10    while (1) {
11        LCD_Limpia();
12        LCD_PreparaBarras(ON, ON, ON, ON);
13        LCD_Texto("UNO");
14        espera(5000000);
15        LCD_Limpia();

```

Build Output

```
assembling startup_stm3211xx_md.s...
compiling system_stm3211xx.c...
linking...
Program Size: Code=6444 RO-data=348 RW-data=32 ZI-data=1632
".\Objects\ej3_1.axf" - 0 Error(s), 0 Warning(s).
Build Time Elapsed: 00:00:00
```

# Prácticas

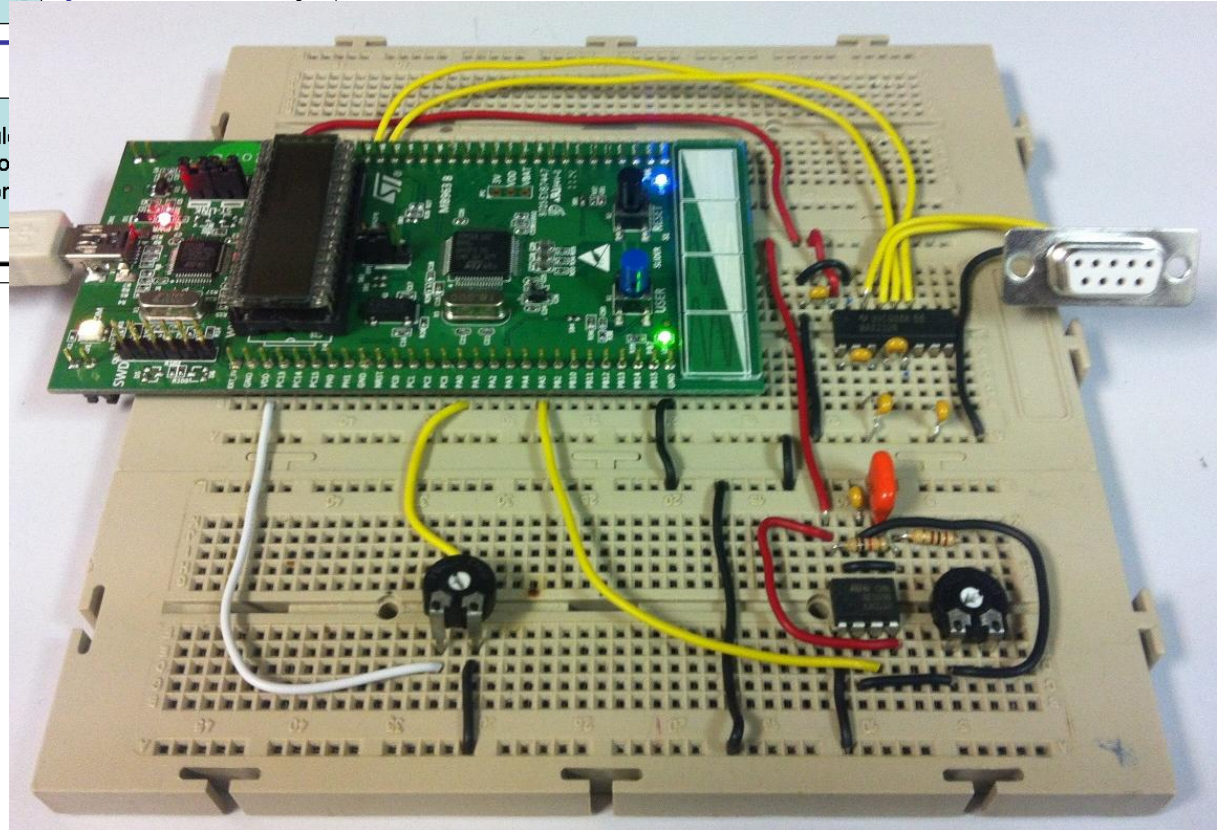
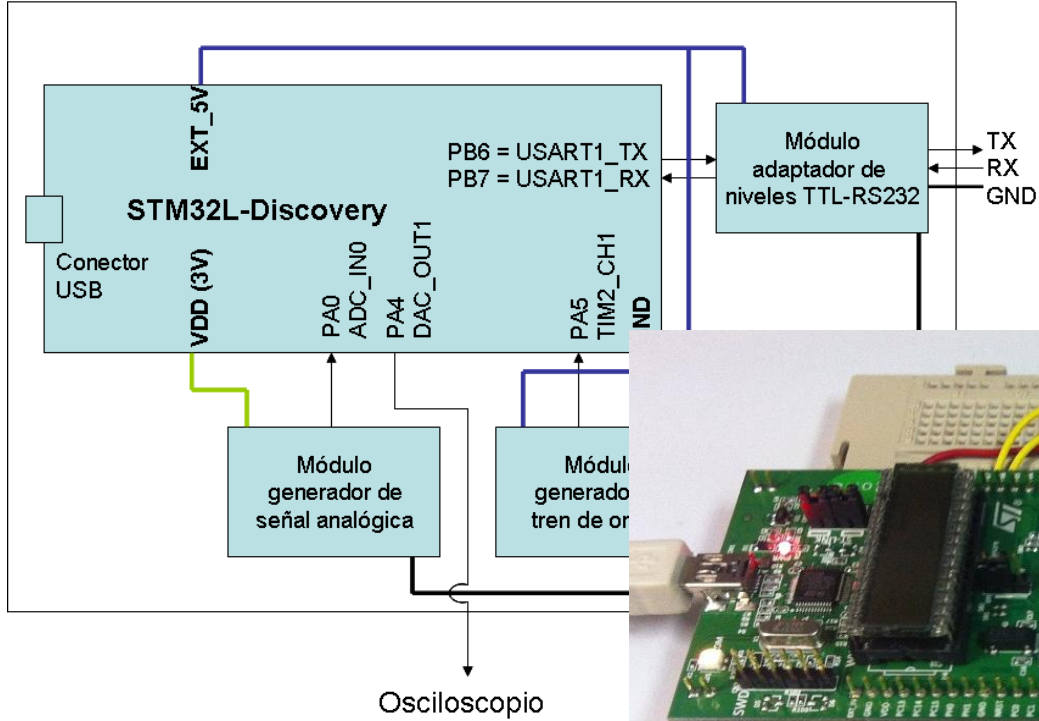



# Bibliografía

- **The Definitive Guide to the ARM Cortex-M3**
  - Joseph Yiu 2007, Elsevier Inc.
- **The Insider's Guide to the STM32 Series ARM® Based Microcontrollers**
  - Trevor Martin 2009, <http://www.hitex.com>
- **Introduction to the ARM® Cortex™-M Architecture**
- **Cortex-M3 Technical Reference Manual**
  - <http://www.arm.com>
- **RM0038 Reference Manual. STM32L151xx and STM32L152xx advanced ARM-based 32-bit MCUs**
  - <http://www.st.com>
- **Datasheet. STM32L151xx and STM32L152xx advanced ARM-based 32-bit MCUs**
  - <http://www.st.com>
- **Keil Tools by ARM: MDK-ARM Microcontroller Development Kit**
  - <http://www.keil.com/arm/mdk.asp>
- **Aula Global: Apuntes, Transparencias, Manuales, Herramientas, Ejemplos, etc.**
  - <https://aulaglobal2.uc3m.es>

# Recursos

- Toda la documentación está disponible en Aula Global:
  - Manuales
  - Presentaciones resumen de los temas
  - Ejercicios
  - Colección de exámenes de años anteriores (resueltos y sin resolver)

The image displays three screenshots of the Aula Global website interface, showing various resource sections for the course 'Curso: MAG. Sistemas digi...'. Each screenshot is a browser window with the URL 'https://aulaglobal.uc3m.es'.

- Left Screenshot:** Shows the 'Transparencias' section with a list of 12 topics (Tema 1: Introducción to Tema 12: Ensamblador) and a 'Prácticas' section with links for 'Selección de grupo de Prácticas', 'Manual de Prácticas', 'Cuestionarios para las prácticas', 'Programas para probar el hardware', and 'Programa para cargar ficheros .hex en la placa'.
- Middle Screenshot:** Shows the 'Exámenes y Calificaciones' section, listing a comprehensive collection of exams and solutions from 2012 to 2015, including partial and final exams for ordinary and extraordinary convocations.
- Right Screenshot:** Shows the 'Material Docente' section, listing various documents such as 'Acuerdo de Préstamo', 'Manual del Microcontrolador (Versión recortada)', 'Manual del Microcontrolador Completo', 'Datasheet del microcontrolador', 'Manual de la placa STM32L-Discovery', and 'Biblioteca SDM'. Below this is the 'Vídeos Docentes' section with links for 'Módulo 2: GPIO, ADC y DAC', 'Módulo 4: Temporizadores', and 'Módulo 5: USART'.

# Introducción Histórica

# Los pioneros: Pascal, Leibniz, Babbage

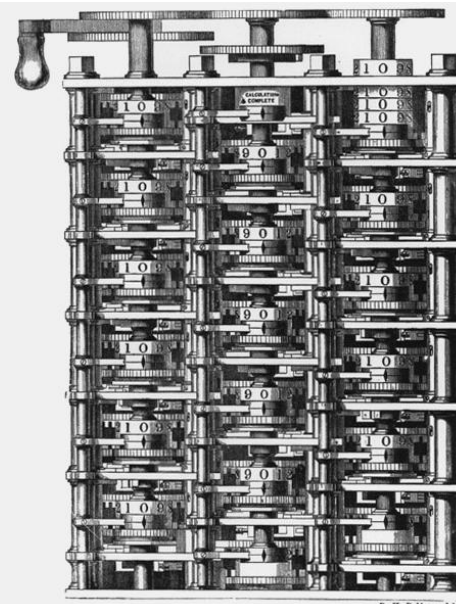
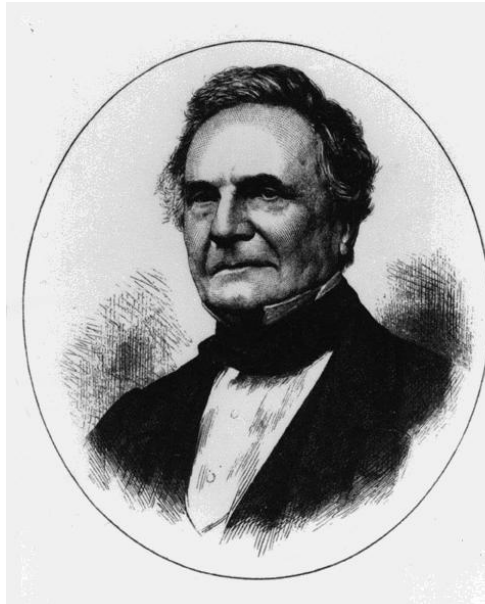
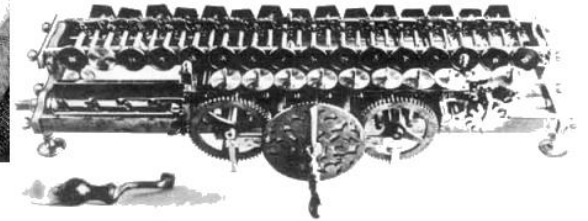

# La Máquina de Tabular. IBM

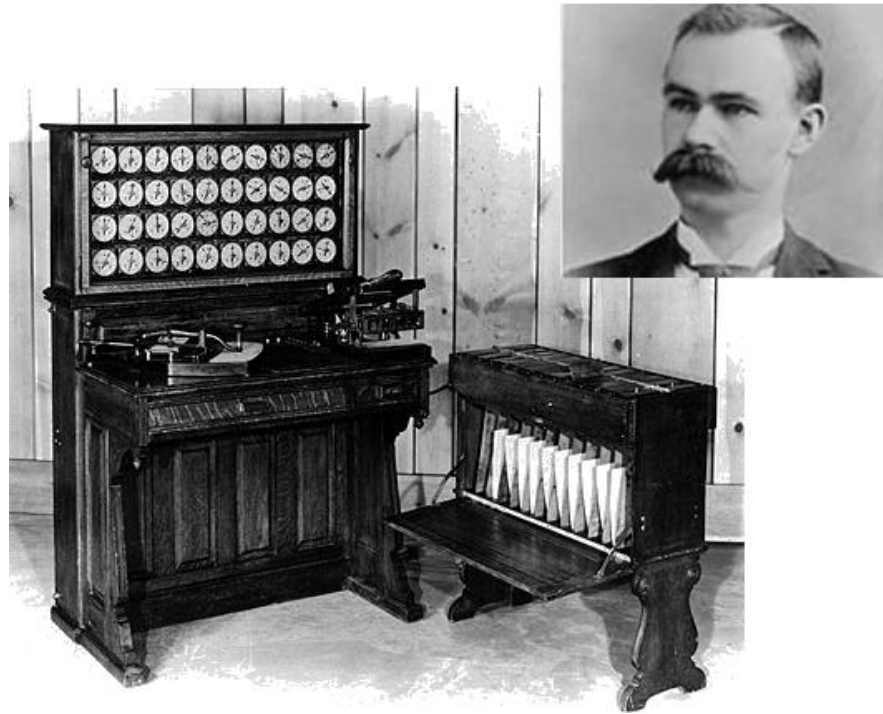

# Dispositivos Electromecánicos



# Los Tubos de Vacío. Turing y el ENIAC

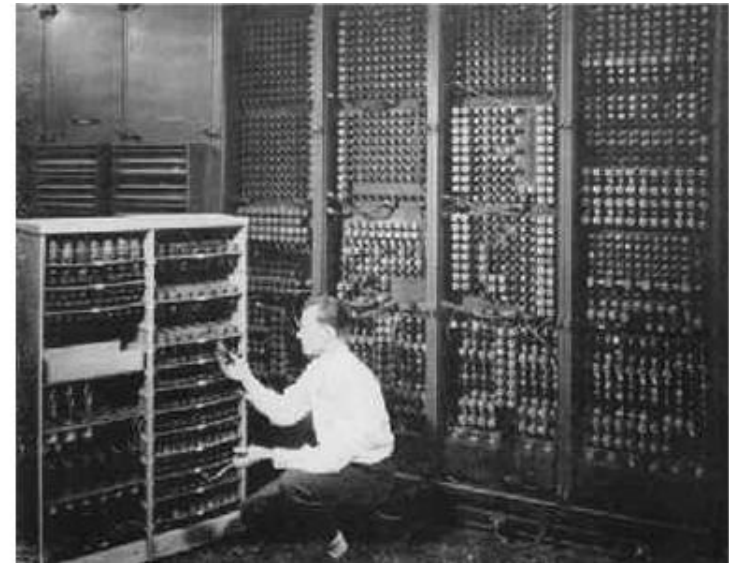
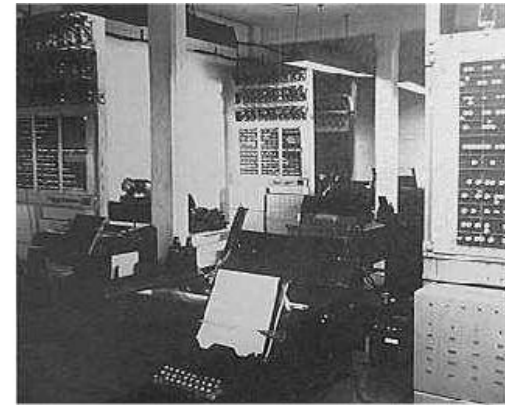

# John Von Neumann

## IAS (*Institute for Advanced Study machine*)

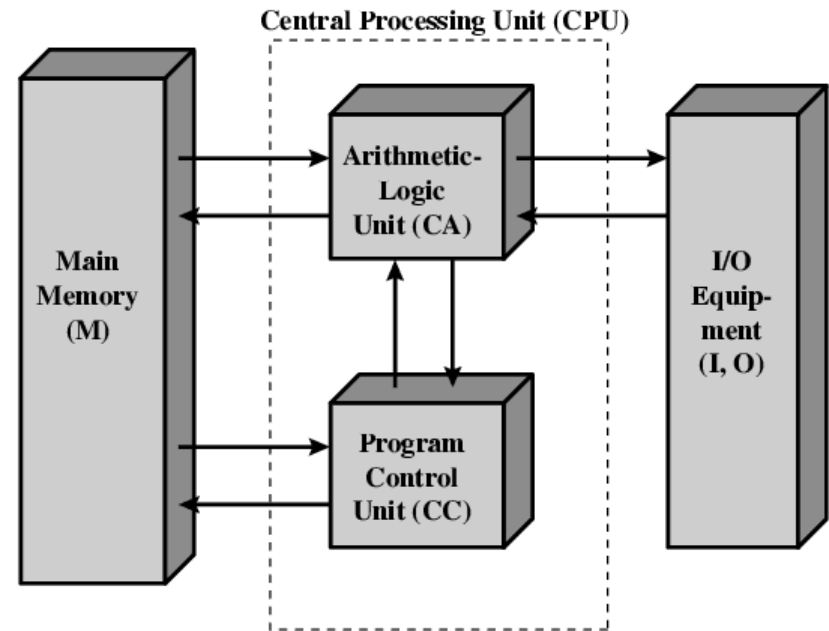
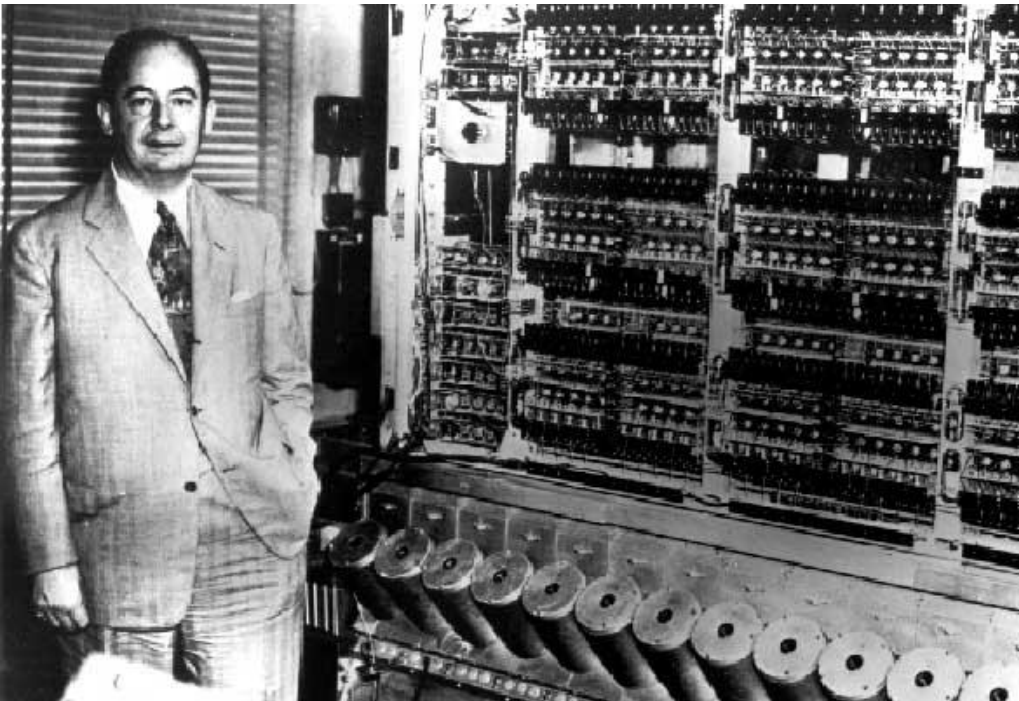



# Dispositivos Semiconductores



# El Circuito Integrado

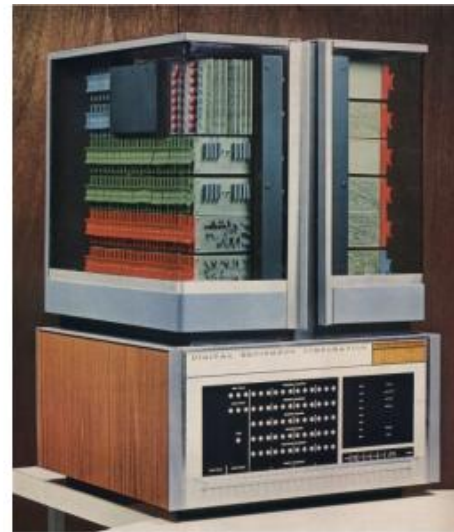
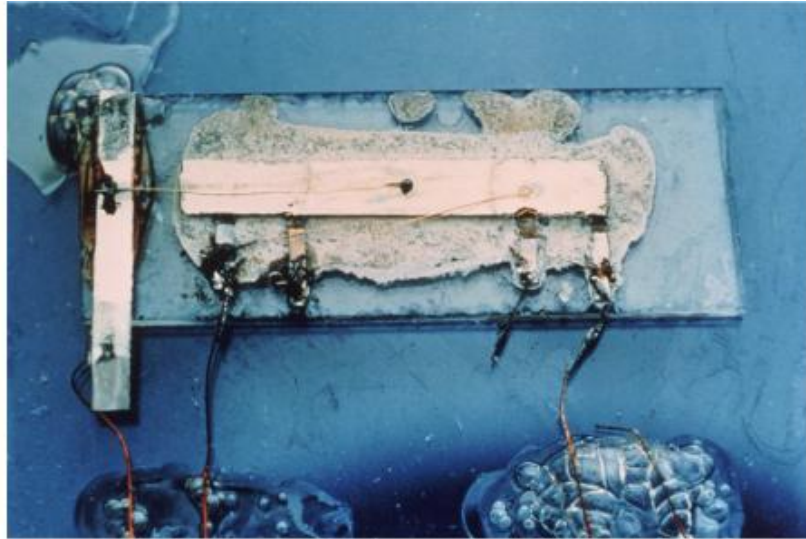
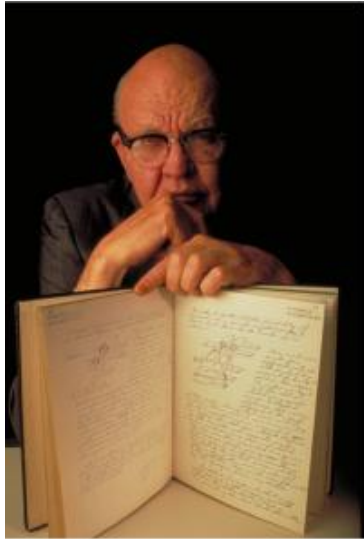

# El Microprocesador. INTEL 4004

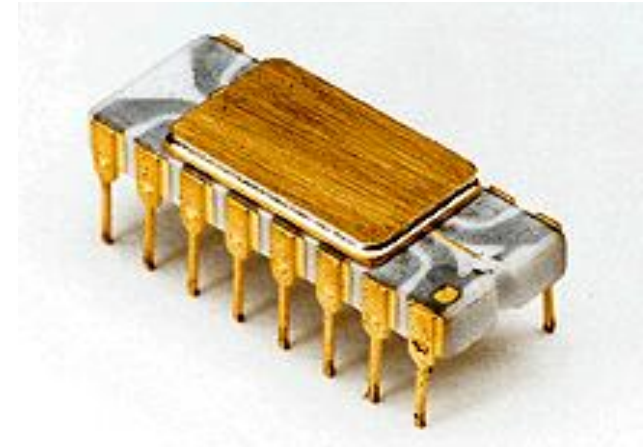
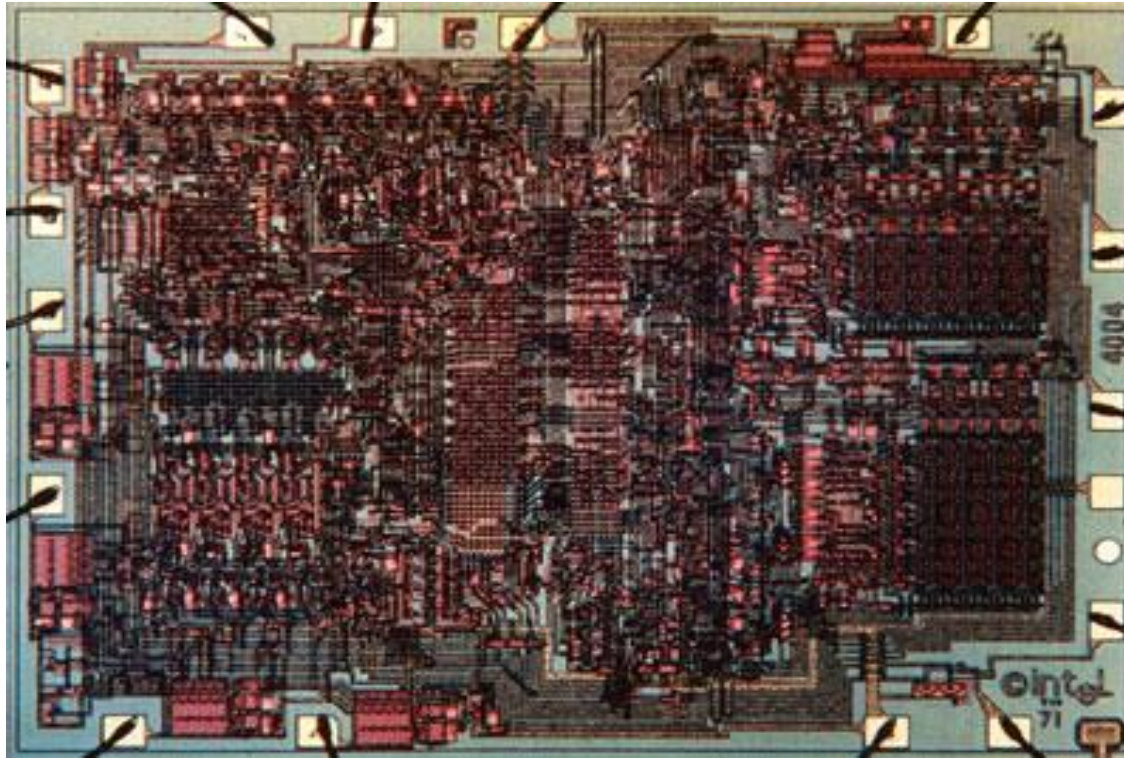

# INTEL 8080

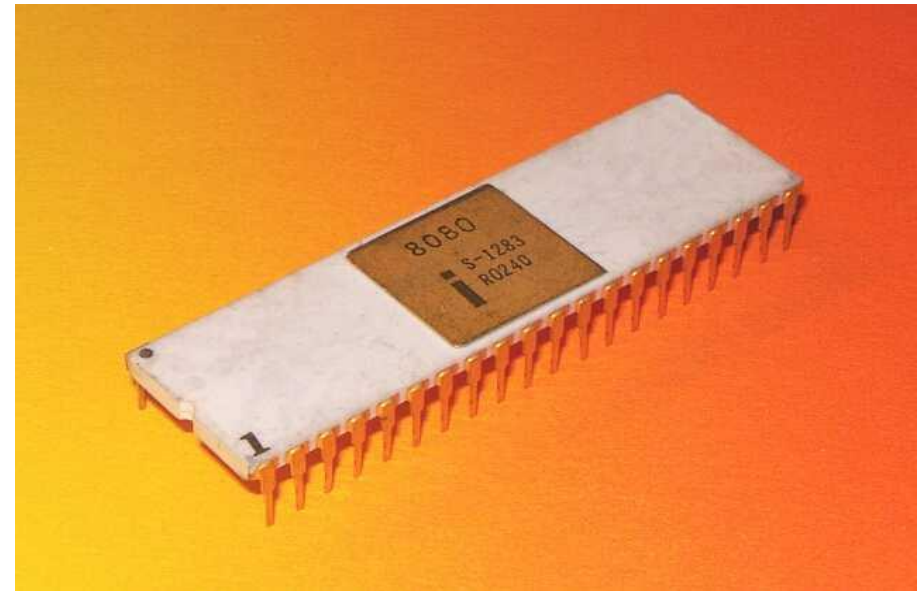
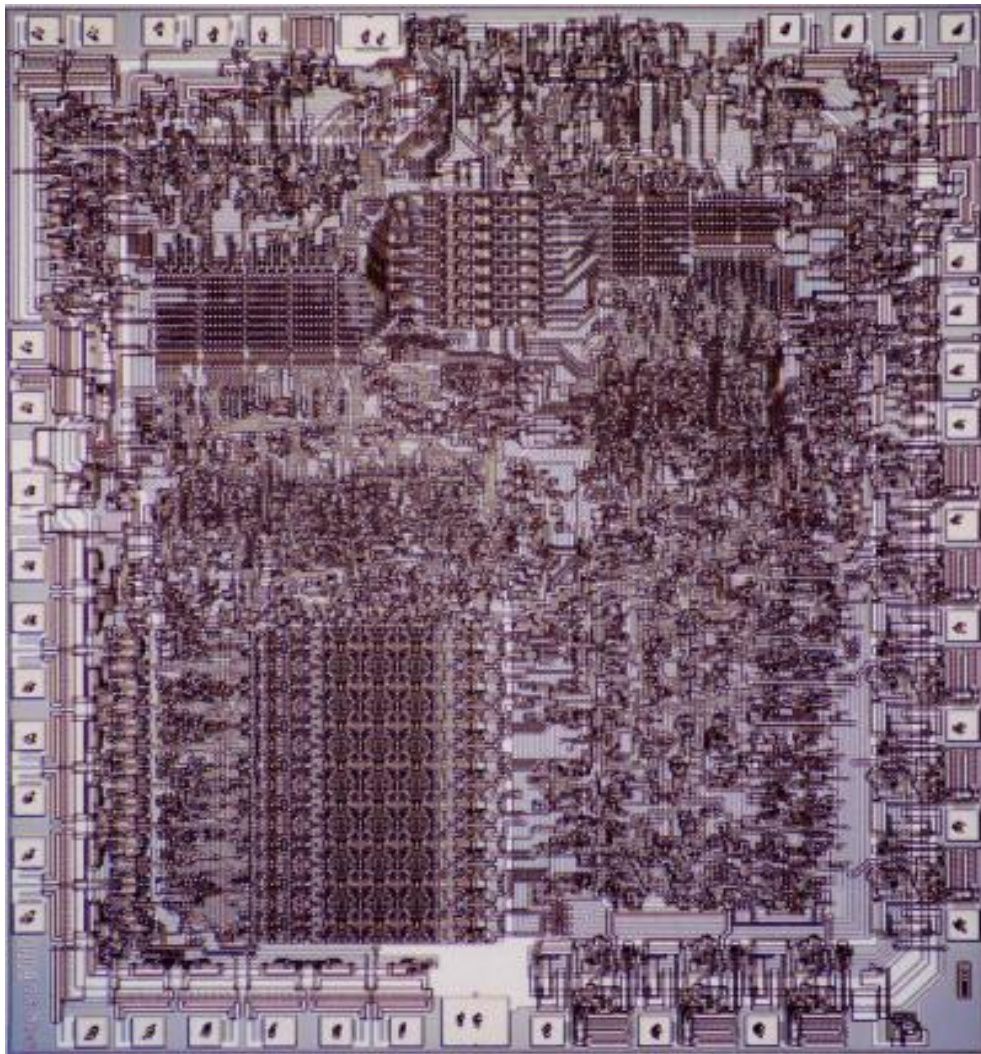

# Los Ordenadores Personales



# INTEL 80286

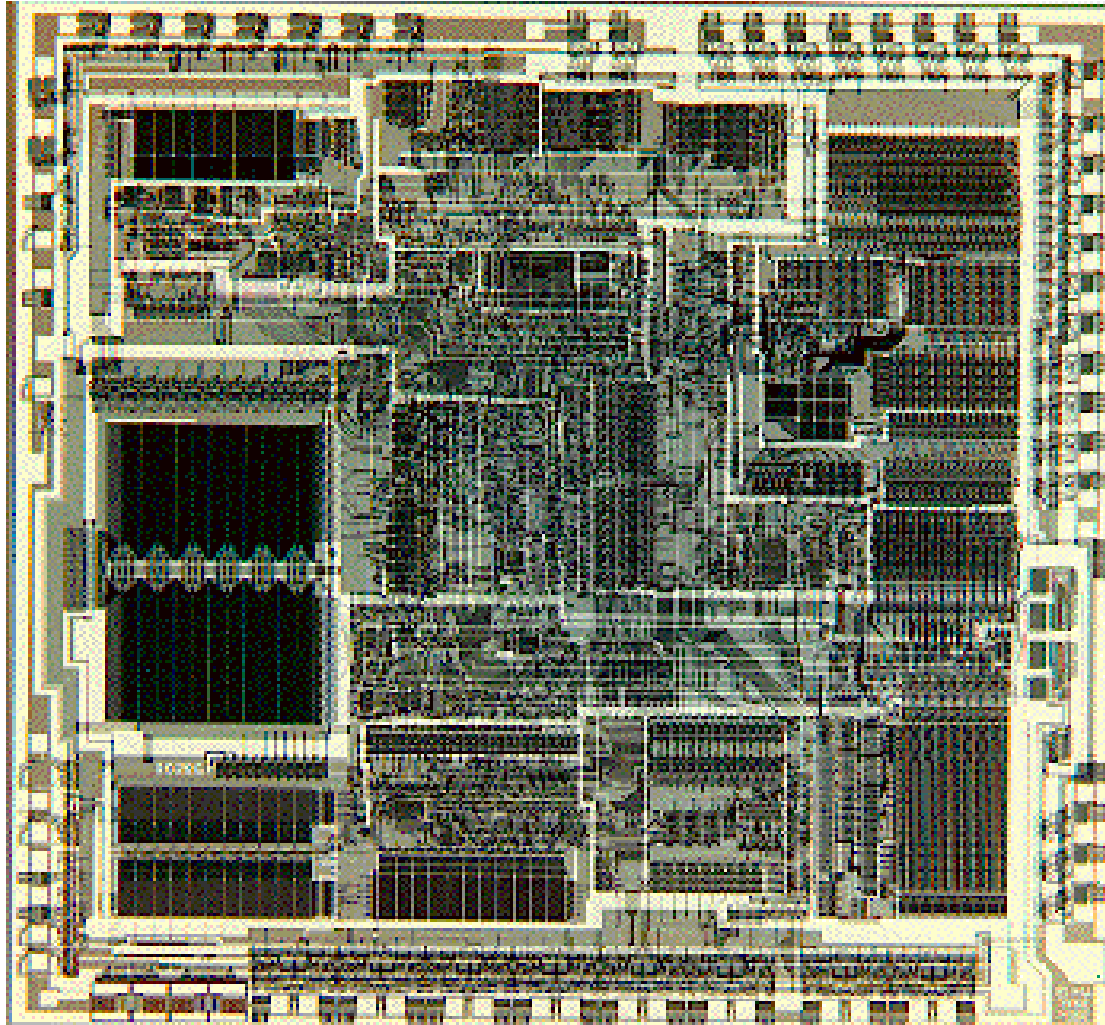

# INTEL 80386

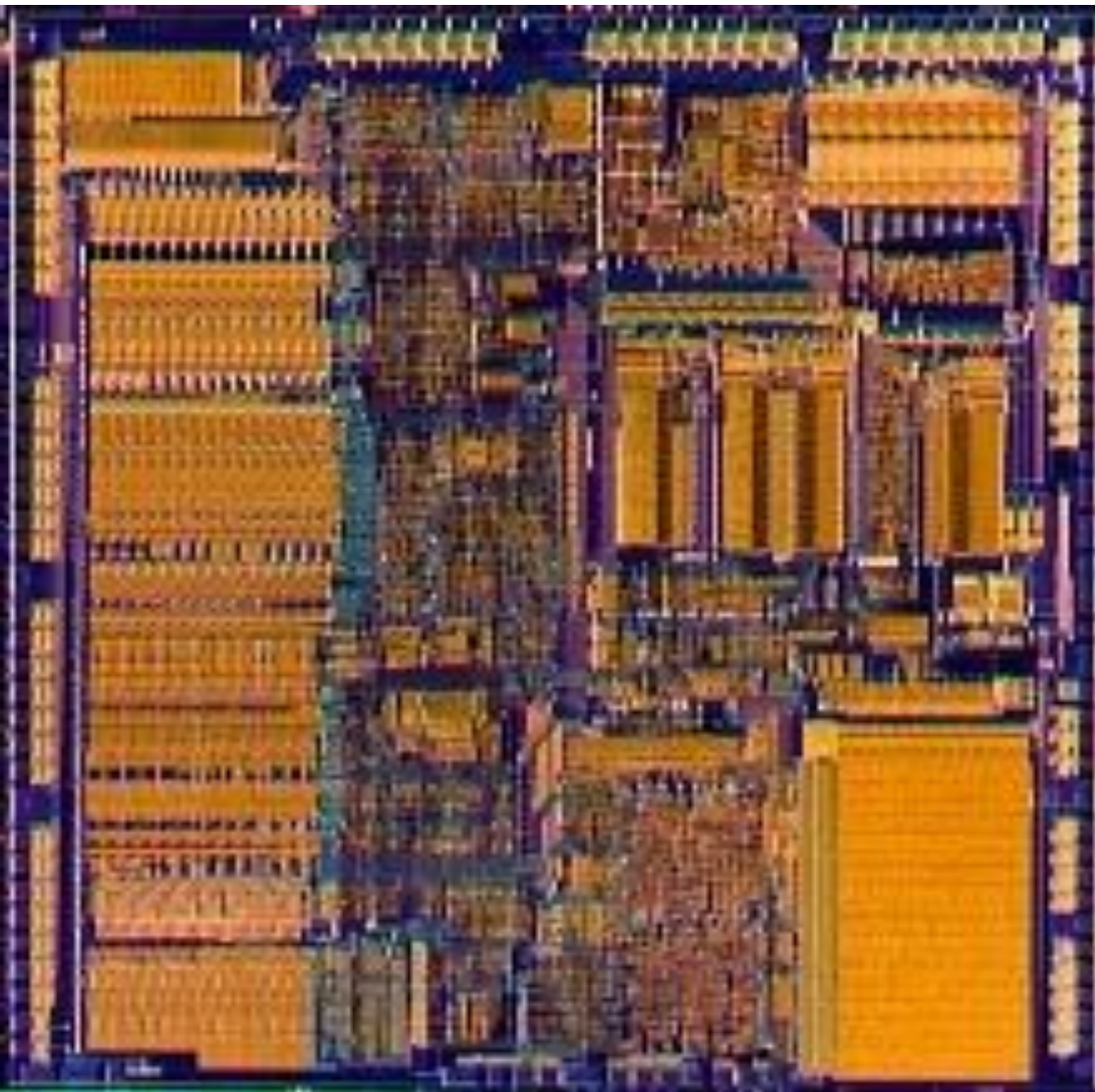

# INTEL 80486

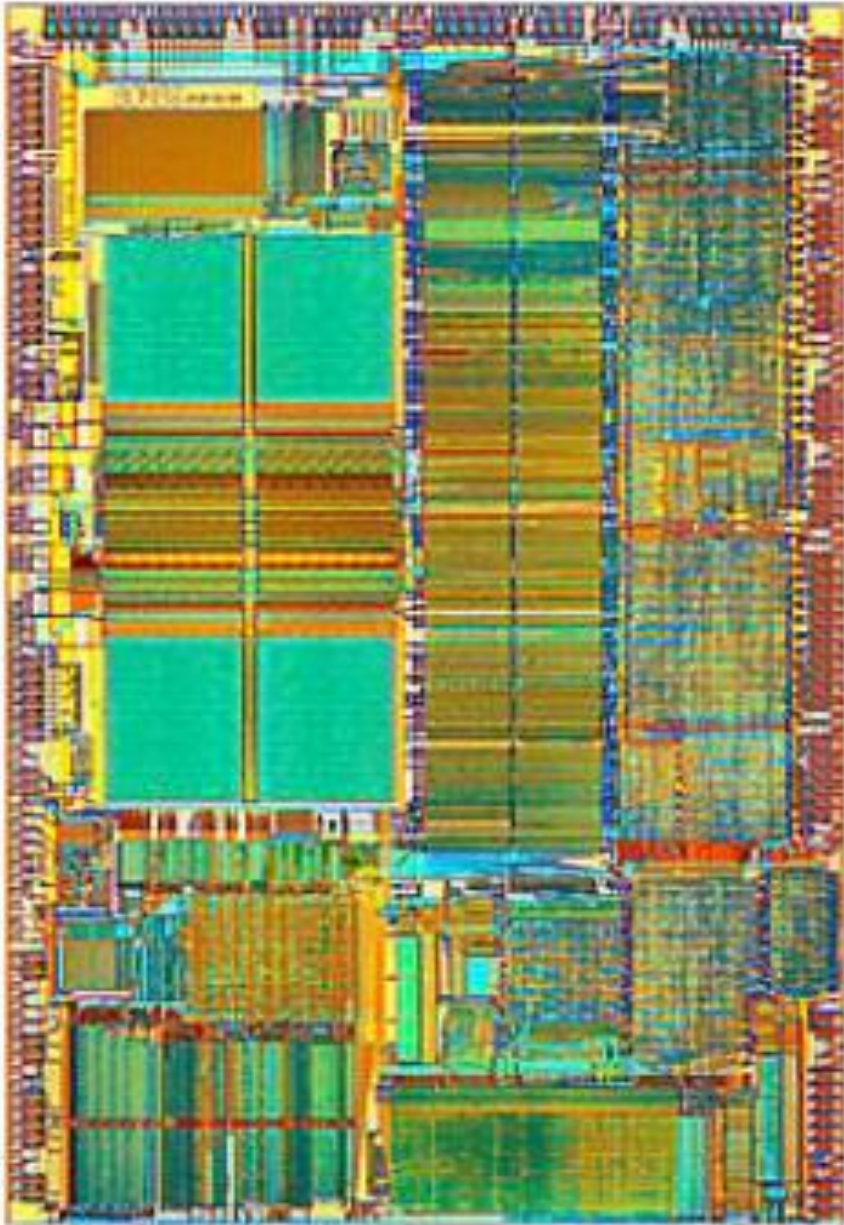



# INTEL Pentium

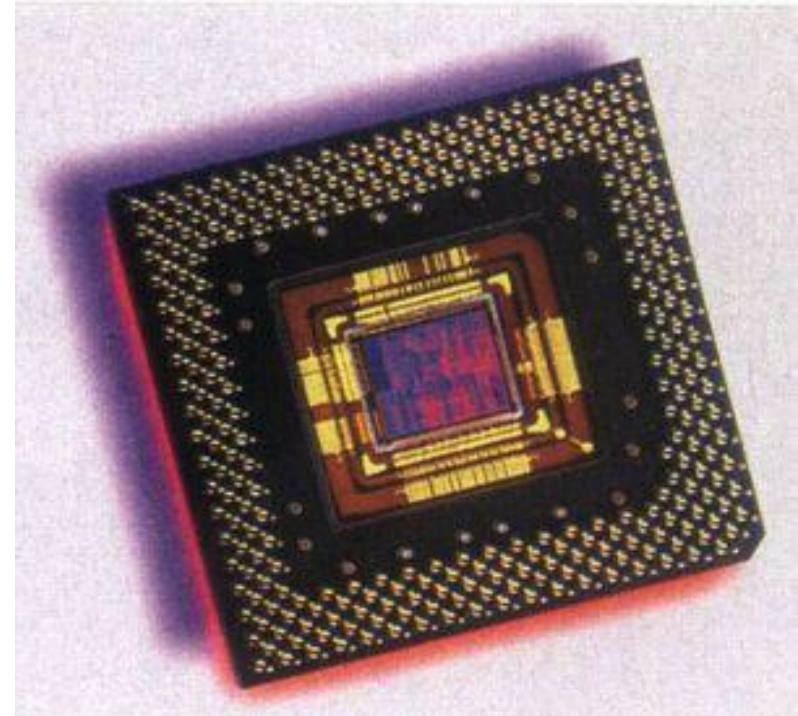
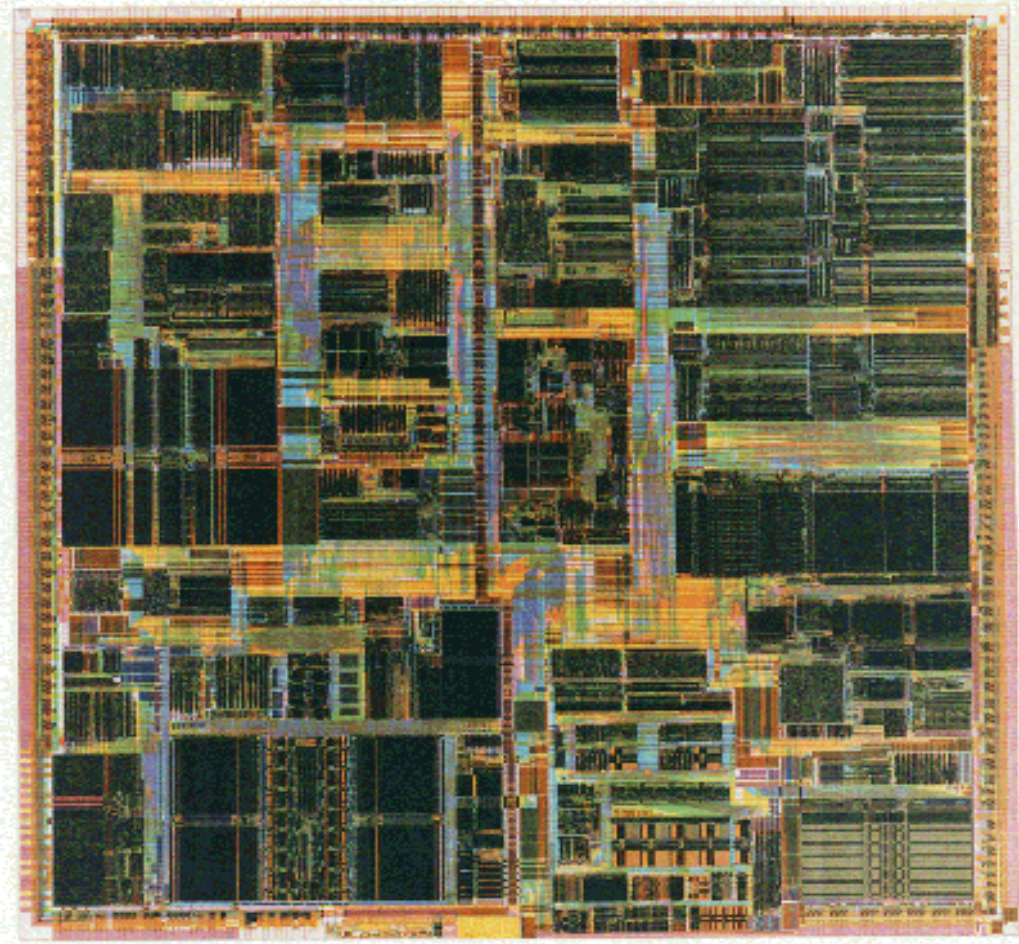

# Ley de Moore

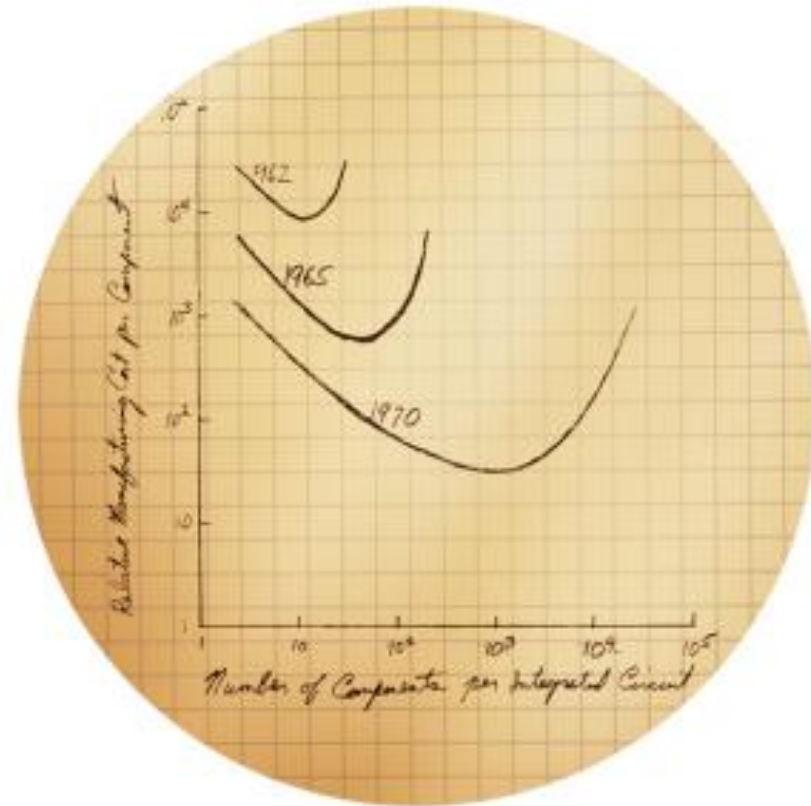
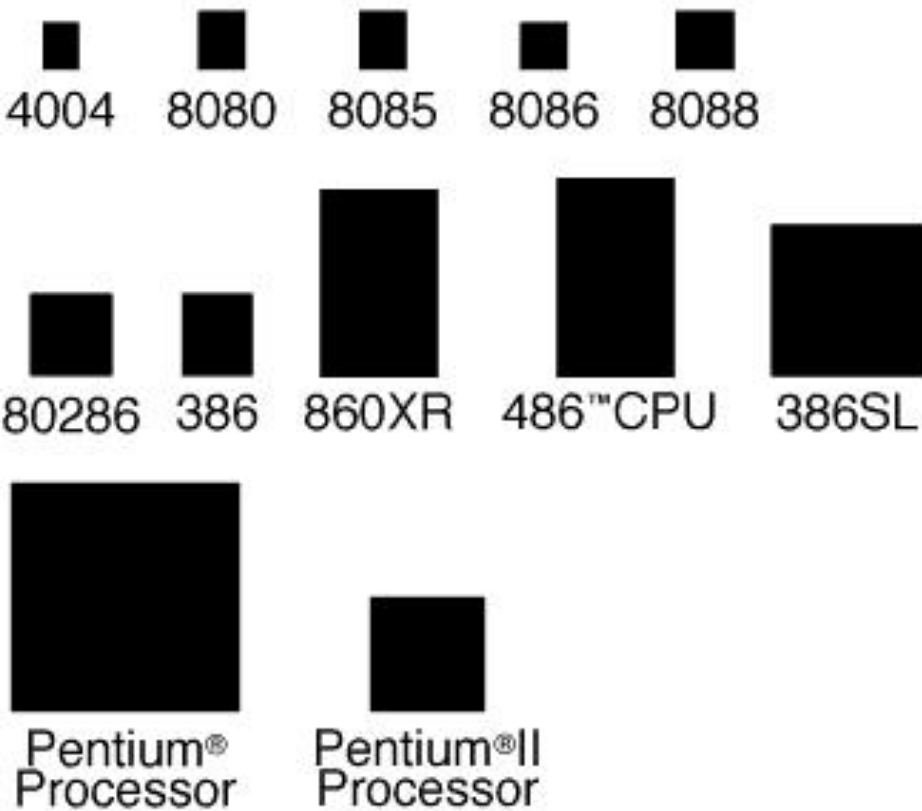

# Ley de Moore

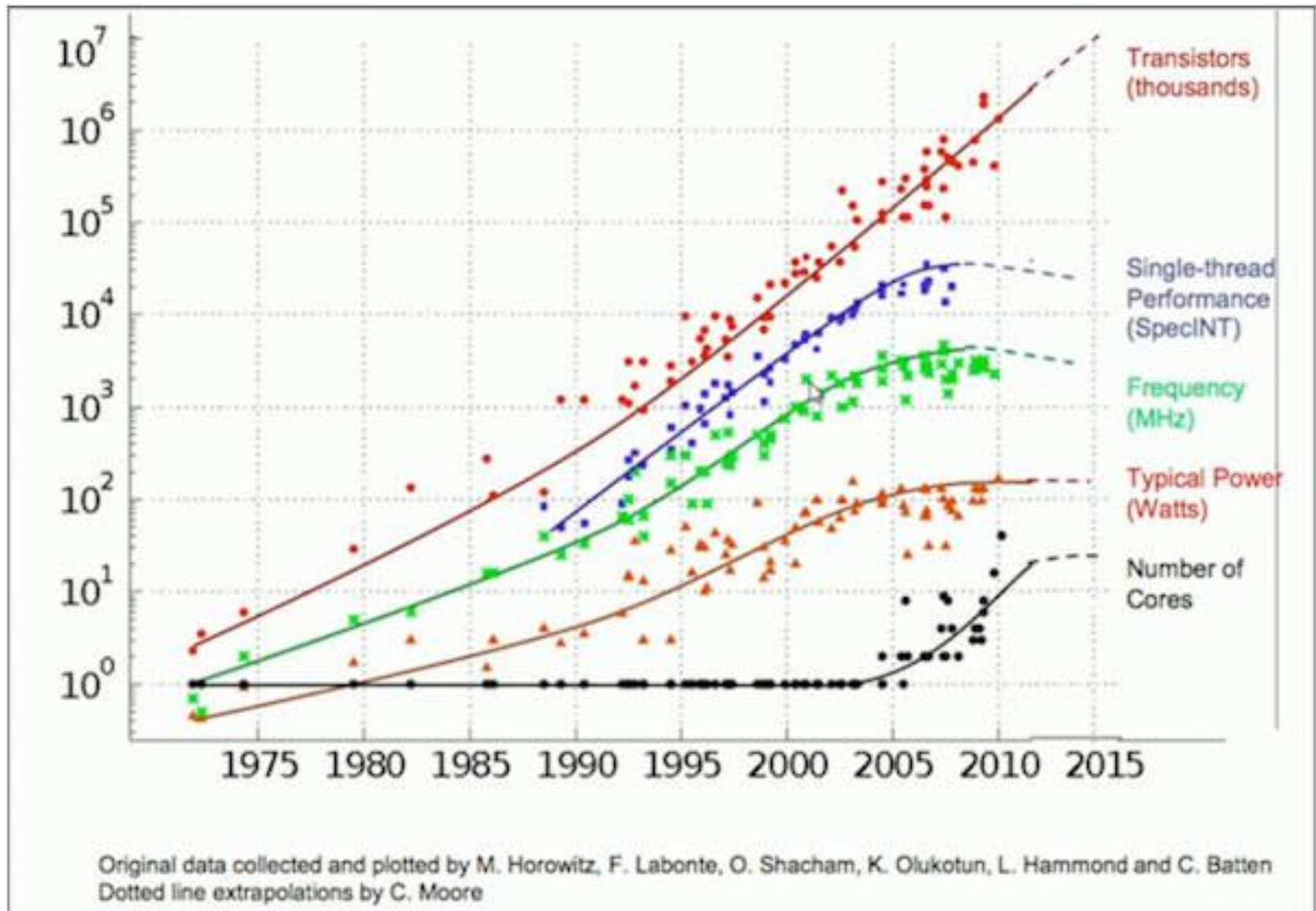

# ... y más allá

