

# **NI Educational Laboratory Virtual Instrumentation Suite (NI ELVIS™)**

## **Hardware User Manual**

## **Worldwide Technical Support and Product Information**

ni.com

### **National Instruments Corporate Headquarters**

11500 North Mopac Expressway Austin, Texas 78759-3504 USA Tel: 512 683 0100

### **Worldwide Offices**

Australia 1800 300 800, Austria 43 0 662 45 79 90 0, Belgium 32 0 2 757 00 20, Brazil 55 11 3262 3599, Canada 800 433 3488, China 86 21 6555 7838, Czech Republic 420 224 235 774, Denmark 45 45 76 26 00, Finland 385 0 9 725 725 11, France 33 0 1 48 14 24 24, Germany 49 0 89 741 31 30, India 91 80 41190000, Israel 972 0 3 6393737, Italy 39 02 413091, Japan 81 3 5472 2970, Korea 82 02 3451 3400, Lebanon 961 0 1 33 28 28, Malaysia 1800 887710, Mexico 01 800 010 0793, Netherlands 31 0 348 433 466, New Zealand 0800 553 322, Norway 47 0 66 90 76 60, Poland 48 22 3390150, Portugal 351 210 311 210, Russia 7 095 783 68 51, Singapore 1800 226 5886, Slovenia 386 3 425 4200, South Africa 27 0 11 805 8197, Spain 34 91 640 0085, Sweden 46 0 8 587 895 00, Switzerland 41 56 200 51 51, Taiwan 886 02 2377 2222, Thailand 662 278 6777, United Kingdom 44 0 1635 523545

For further support information, refer to the *Signal Conditioning Technical Support Information* document. To comment on National Instruments documentation, refer to the National Instruments Web site at [ni.com/info](http://ni.com/info) and enter the info code `feedback`.

# Important Information

---

## Warranty

The NI-ELVIS hardware is warranted against defects in materials and workmanship for a period of one year from the date of shipment, as evidenced by receipts or other documentation. National Instruments will, at its option, repair or replace equipment that proves to be defective during the warranty period. This warranty includes parts and labor.

The media on which you receive National Instruments software are warranted not to fail to execute programming instructions, due to defects in materials and workmanship, for a period of 90 days from date of shipment, as evidenced by receipts or other documentation. National Instruments will, at its option, repair or replace software media that do not execute programming instructions if National Instruments receives notice of such defects during the warranty period. National Instruments does not warrant that the operation of the software shall be uninterrupted or error free.

A Return Material Authorization (RMA) number must be obtained from the factory and clearly marked on the outside of the package before any equipment will be accepted for warranty work. National Instruments will pay the shipping costs of returning to the owner parts which are covered by warranty.

National Instruments believes that the information in this document is accurate. The document has been carefully reviewed for technical accuracy. In the event that technical or typographical errors exist, National Instruments reserves the right to make changes to subsequent editions of this document without prior notice to holders of this edition. The reader should consult National Instruments if errors are suspected. In no event shall National Instruments be liable for any damages arising out of or related to this document or the information contained in it.

EXCEPT AS SPECIFIED HEREIN, NATIONAL INSTRUMENTS MAKES NO WARRANTIES, EXPRESS OR IMPLIED, AND SPECIFICALLY DISCLAIMS ANY WARRANTY OF MERCHANTABILITY OR FITNESS FOR A PARTICULAR PURPOSE. CUSTOMER'S RIGHT TO RECOVER DAMAGES CAUSED BY FAULT OR NEGLIGENCE ON THE PART OF NATIONAL INSTRUMENTS SHALL BE LIMITED TO THE AMOUNT THEREOF PAID BY THE CUSTOMER. NATIONAL INSTRUMENTS WILL NOT BE LIABLE FOR DAMAGES RESULTING FROM LOSS OF DATA, PROFITS, USE OF PRODUCTS, OR INCIDENTAL OR CONSEQUENTIAL DAMAGES, EVEN IF ADVISED OF THE POSSIBILITY THEREOF. This limitation of the liability of National Instruments will apply regardless of the form of action, whether in contract or tort, including negligence. Any action against National Instruments must be brought within one year after the cause of action accrues. National Instruments shall not be liable for any delay in performance due to causes beyond its reasonable control. The warranty provided herein does not cover damages, defects, malfunctions, or service failures caused by owner's failure to follow the National Instruments installation, operation, or maintenance instructions; owner's modification of the product; owner's abuse, misuse, or negligent acts; and power failure or surges, fire, flood, accident, actions of third parties, or other events outside reasonable control.

## Copyright

Under the copyright laws, this publication may not be reproduced or transmitted in any form, electronic or mechanical, including photocopying, recording, storing in an information retrieval system, or translating, in whole or in part, without the prior written consent of National Instruments Corporation.

National Instruments respects the intellectual property of others, and we ask our users to do the same. NI software is protected by copyright and other intellectual property laws. Where NI software may be used to reproduce software or other materials belonging to others, you may use NI software only to reproduce materials that you may reproduce in accordance with the terms of any applicable license or other legal restriction.

## Trademarks

National Instruments, NI, ni.com, and LabVIEW are trademarks of National Instruments Corporation. Refer to the *Terms of Use* section on [ni.com/legal](http://ni.com/legal) for more information about National Instruments trademarks.

Other product and company names mentioned herein are trademarks or trade names of their respective companies.

## Patents

For patents covering National Instruments products, refer to the appropriate location: **Help»Patents** in your software, the `patents.txt` file on your CD, or [ni.com/patents](http://ni.com/patents).

## WARNING REGARDING USE OF NATIONAL INSTRUMENTS PRODUCTS





(1) NATIONAL INSTRUMENTS PRODUCTS ARE NOT DESIGNED WITH COMPONENTS AND TESTING FOR A LEVEL OF RELIABILITY SUITABLE FOR USE IN OR IN CONNECTION WITH SURGICAL IMPLANTS OR AS CRITICAL COMPONENTS IN ANY LIFE SUPPORT SYSTEMS WHOSE FAILURE TO PERFORM CAN REASONABLY BE EXPECTED TO CAUSE SIGNIFICANT INJURY TO A HUMAN.

(2) IN ANY APPLICATION, INCLUDING THE ABOVE, RELIABILITY OF OPERATION OF THE SOFTWARE PRODUCTS CAN BE IMPAIRED BY ADVERSE FACTORS, INCLUDING BUT NOT LIMITED TO FLUCTUATIONS IN ELECTRICAL POWER SUPPLY, COMPUTER HARDWARE MALFUNCTIONS, COMPUTER OPERATING SYSTEM SOFTWARE FITNESS, FITNESS OF COMPILERS AND DEVELOPMENT SOFTWARE USED TO DEVELOP AN APPLICATION, INSTALLATION ERRORS, SOFTWARE AND HARDWARE COMPATIBILITY PROBLEMS, MALFUNCTIONS OR FAILURES OF ELECTRONIC MONITORING OR CONTROL DEVICES, TRANSIENT FAILURES OF ELECTRONIC SYSTEMS (HARDWARE AND/OR SOFTWARE), UNANTICIPATED USES OR MISUSES, OR ERRORS ON THE PART OF THE USER OR APPLICATIONS DESIGNER (ADVERSE FACTORS SUCH AS THESE ARE HEREAFTER COLLECTIVELY TERMED "SYSTEM FAILURES"). ANY APPLICATION WHERE A SYSTEM FAILURE WOULD CREATE A RISK OF HARM TO PROPERTY OR PERSONS (INCLUDING THE RISK OF BODILY INJURY AND DEATH) SHOULD NOT BE RELIANT SOLELY UPON ONE FORM OF ELECTRONIC SYSTEM DUE TO THE RISK OF SYSTEM FAILURE. TO AVOID DAMAGE, INJURY, OR DEATH, THE USER OR APPLICATION DESIGNER MUST TAKE REASONABLY PRUDENT STEPS TO PROTECT AGAINST SYSTEM FAILURES, INCLUDING BUT NOT LIMITED TO BACK-UP OR SHUT DOWN MECHANISMS. BECAUSE EACH END-USER SYSTEM IS CUSTOMIZED AND DIFFERS FROM NATIONAL INSTRUMENTS' TESTING PLATFORMS AND BECAUSE A USER OR APPLICATION DESIGNER MAY USE NATIONAL INSTRUMENTS PRODUCTS IN COMBINATION WITH OTHER PRODUCTS IN A MANNER NOT EVALUATED OR CONTEMPLATED BY NATIONAL INSTRUMENTS, THE USER OR APPLICATION DESIGNER IS ULTIMATELY RESPONSIBLE FOR VERIFYING AND VALIDATING THE SUITABILITY OF NATIONAL INSTRUMENTS PRODUCTS WHENEVER NATIONAL INSTRUMENTS PRODUCTS ARE INCORPORATED IN A SYSTEM OR APPLICATION, INCLUDING, WITHOUT LIMITATION, THE APPROPRIATE DESIGN, PROCESS AND SAFETY LEVEL OF SUCH SYSTEM OR APPLICATION.

# Conventions

---

The following conventions are used in this manual:

<>	Angle brackets that contain numbers separated by an ellipsis represent a range of values associated with a bit or signal name—for example, AO <3..0>.
»	The » symbol leads you through nested menu items and dialog box options to a final action. The sequence <b>File»Page Setup»Options</b> directs you to pull down the <b>File</b> menu, select the <b>Page Setup</b> item, and select <b>Options</b> from the last dialog box.
	This icon denotes a note, which alerts you to important information.
	This icon denotes a caution, which advises you of precautions to take to avoid injury, data loss, or a system crash. When this icon is marked on the product, refer to the <i>Read Me First: Safety and Radio-Frequency Interference</i> document, shipped with the product, for precautions to take.
	When symbol is marked on a product, it denotes a warning advising you to take precautions to avoid electrical shock.
	When symbol is marked on a product, it denotes a component that may be hot. Touching this component may result in bodily injury.
<b>bold</b>	Bold text denotes items that you must select or click in the software, such as menu items and dialog box options. Bold text also denotes parameter names.
DAQ device	DAQ device refers to any National Instrument DAQ device that meets the conditions listed in Chapter 3, <i>Hardware Overview</i> .
ELVIS	Educational Laboratory Virtual Instrumentation Suite.
<i>italic</i>	Italic text denotes variables, emphasis, a cross-reference, or an introduction to a key concept. Italic text also denotes text that is a placeholder for a word or value that you must supply.
monospace	Text in this font denotes text or characters that you should enter from the keyboard, sections of code, programming examples, and syntax examples. This font is also used for the proper names of disk drives, paths, directories, programs, subprograms, subroutines, device names, functions, operations, variables, filenames, and extensions.

# Contents

---

## Chapter 1

### DAQ System Overview

What is Virtual Instrumentation?.....	1-1
What is DAQ?.....	1-2
DAQ Hardware.....	1-3
DAQ Software .....	1-3
LabVIEW .....	1-3
SignalExpress.....	1-4
NI ELVIS Overview .....	1-4
Related Documentation.....	1-5

## Chapter 2

### NI ELVIS Overview

NI ELVIS Hardware .....	2-2
NI ELVIS Benchtop Workstation .....	2-2
NI ELVIS Prototyping Board.....	2-3
NI ELVIS Software .....	2-3
SFP Instruments.....	2-3
Instrument Launcher .....	2-4
Arbitrary Waveform Generator (ARB).....	2-4
Bode Analyzer.....	2-5
Digital Bus Reader.....	2-5
Digital Bus Writer.....	2-5
Digital Multimeter (DMM).....	2-5
Dynamic Signal Analyzer (DSA) .....	2-6
Function Generator (FGEN) .....	2-6
Impedance Analyzer .....	2-6
Oscilloscope (Scope).....	2-6
Two-Wire and Three-Wire Current-Voltage Analyzers .....	2-7
Variable Power Supplies.....	2-7
Using NI ELVIS with LabVIEW .....	2-7
LabVIEW Express VIs.....	2-7
Low Level NI ELVIS API .....	2-8
Using NI-DAQmx with NI ELVIS .....	2-9
Using NI ELVIS in SignalExpress .....	2-9
NI ELVIS Calibration Utility .....	2-9

NI ELVIS in Academic Disciplines .....	2-10
NI ELVIS in Engineering .....	2-10
NI ELVIS in Biological Sciences .....	2-10
NI ELVIS in Physical Sciences .....	2-11

## Chapter 3 Hardware Overview

DAQ Hardware .....	3-1
Recommended DAQ Devices .....	3-1
NI ELVIS Benchtop Workstation .....	3-2
NI ELVIS Rear Panel .....	3-5
NI ELVIS Protection Board .....	3-6
NI ELVIS Prototyping Board .....	3-6
Prototyping Board Power .....	3-7
Prototyping Board Signal Descriptions .....	3-8
PFI Signal Descriptions .....	3-11
Connecting Signals .....	3-11
Grounding Considerations .....	3-12
Connecting Analog Input Signals .....	3-12
Generic Analog Input .....	3-12
Resource Conflicts .....	3-13
DMM .....	3-14
Oscilloscope .....	3-14
Connecting Analog Output Signals .....	3-14
Generic Analog Output .....	3-14
DC Power Supplies .....	3-15
Function Generator (FGEN) .....	3-15
Variable Power Supplies .....	3-15
Bode Analyzer .....	3-15
Two-Wire Current-Voltage Analyzer .....	3-15
Three-Wire Current-Voltage Analyzer .....	3-16
Impedance Analyzer .....	3-16
Connecting Digital I/O Signals .....	3-16
Connecting Counter/Timer Signals .....	3-16
Connecting User-Configurable Signals .....	3-16

## Chapter 4 Calibration

Running the NI ELVIS Calibration Utility .....	4-1
--	-----

**Appendix A  
Specifications**

**Appendix B  
Protection Board Fuses**

**Appendix C  
Theory of Operation**

**Appendix D  
Resource Conflicts**

**Appendix E  
Supported DAQ Devices**

**Appendix F  
Using Bypass Communication Mode**

**Appendix G  
Common Questions**

**Glossary**

**Index**

**Figures**

Figure 1-1.	Typical DAQ System .....	1-3
Figure 2-1.	Parts Locator Diagram for Desktop NI ELVIS Systems.....	2-1
Figure 2-2.	Parts Locator Diagram for USB NI ELVIS Systems .....	2-2
Figure 3-1.	Control Panel Diagram of the Benchtop Workstation.....	3-2
Figure 3-2.	Back View of NI ELVIS Benchtop Workstation .....	3-5
Figure 3-3.	Prototyping Board Parts Locator Diagram.....	3-7
Figure B-1.	NI ELVIS Benchtop Workstation with Protection Board Removed.....	B-1
Figure B-2.	Parts Locator Diagram for NI ELVIS Protection Board .....	B-3

Figure C-1.	NI ELVIS Voltmeter Block Diagram .....	C-2
Figure C-2.	NI ELVIS Current Meter Block Diagram.....	C-4
Figure C-3.	Function Generator Block Diagram.....	C-6
Figure C-4.	Impedance Analyzer Block Diagram.....	C-7
Figure C-5.	CURRENT HI Block Diagram .....	C-8
Figure C-6.	CURRENT LO Block Diagram .....	C-9
Figure C-7.	Two-Wire Measurement Block Diagram.....	C-12
Figure C-8.	Three-Wire Measurement Block Diagram.....	C-14
Figure C-9.	Analog Output Block Diagram .....	C-15
Figure D-1.	Possible Resource Conflicts.....	D-2
Figure F-1.	NI ELVIS – Enable Communications Bypass VI.....	F-2

## Tables

Table 2-1.	NI ELVIS Express VIs.....	2-8
Table 3-1.	Signal Descriptions .....	3-8
Table 3-2.	M Series DAQ Device Routing .....	3-10
Table 3-3.	Analog Input Signal Mapping .....	3-12
Table 3-4.	AI Channel Resource Conflicts .....	3-13
Table 3-5.	NPN Transistor to Prototyping Board Connections.....	3-16
Table B-1.	Resistor Packs and NI ELVIS Components.....	B-4
Table E-1.	E/B Series DAQ Device Routing.....	E-3



---

# DAQ System Overview

The *NI ELVIS User Manual* contains information that you need to understand and program the National Instruments Educational Laboratory Virtual Instrumentation Suite (NI ELVIS) architecture and instruments. It also discusses the concept of virtual instrumentation and the components of an NI data acquisition (DAQ) system.

This chapter briefly describes the concept of DAQ systems and introduces NI ELVIS, a DAQ system designed for educational laboratories.



**Note** Refer to the *Where to Start with NI ELVIS* document for information about how to set up the components of the NI ELVIS.

---

## What is Virtual Instrumentation?

*Virtual instrumentation* is defined as the combination of measurement and control hardware and application software with industry-standard computer technology to create user-defined instrumentation systems.

Virtual instrumentation provides an ideal platform for developing instructional curriculum and conducting scientific research. In an instructional laboratory course, students perform various experiments that combine measurements, automation, and control. Tools or systems used in these situations must be flexible and adaptable. In research environments, virtual instrumentation provides the flexibility that a researcher must have to modify the system to meet unpredictable needs. Research and instructional efforts also require that their systems be economical. Because you can reuse components in a virtual instrumentation system (without purchasing additional hardware or software), virtual instrumentation is an economical choice. Finally, measurement systems must be scalable to meet future expansion needs. The modular nature of virtual instrumentation makes it easy for you to add new functionality.

NI ELVIS uses LabVIEW-based software and NI data acquisition hardware to create a virtual instrumentation system that provides the functionality of a suite of instruments.

## What is DAQ?

---

DAQ systems capture, measure, and analyze physical phenomena from the real world. Light, temperature, pressure, and torque are examples of the different types of signals that a DAQ system can measure. Data acquisition is the process of collecting and measuring electrical signals from transducers and test probes or fixtures, and sending them to a computer for processing. Data acquisition can also include the output of analog or digital control signals.

The building blocks of a DAQ system include the following items:

- **Transducer**—A device that converts a physical phenomenon such as light, temperature, pressure, or sound into a measurable electrical signal such as voltage or current.
- **Signal**—The output of the DAQ system transducer.
- **Signal conditioning**—Hardware that you can connect to the DAQ device to make the signal suitable for measurement or to improve accuracy or reduce noise. The most common types of signal conditioning include amplification, excitation, linearization, isolation, and filtering.
- **DAQ hardware**—Hardware used to acquire, measure, and analyze data.
- **Software**—NI application software is designed to help you easily design and program measurement and control applications.

Figure 1-1 shows the components of a typical DAQ system.

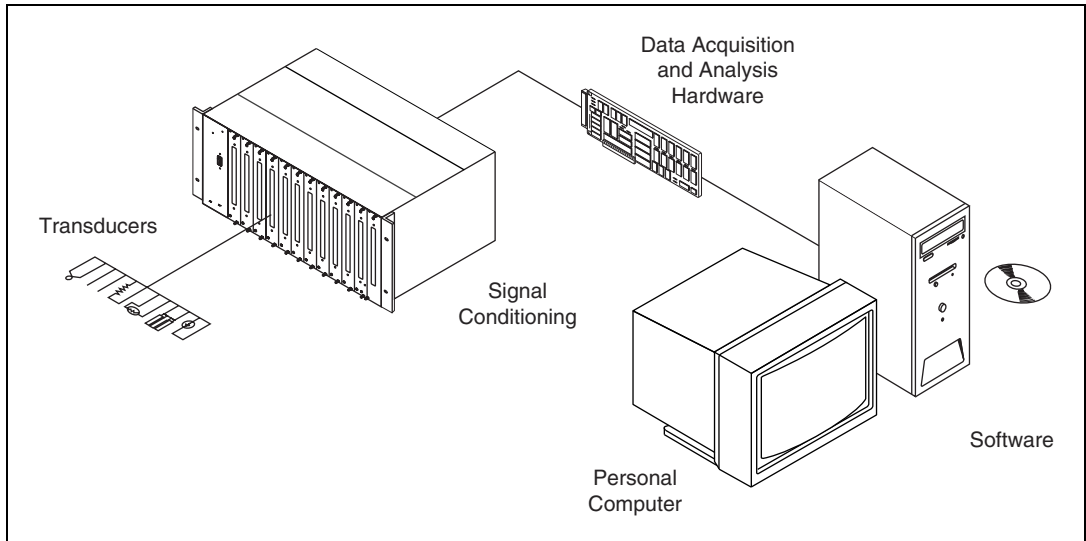

**Figure 1-1.** Typical DAQ System

## DAQ Hardware

The *DAQ Hardware* section of Chapter 3, *Hardware Overview*, describes in greater detail the DAQ device used as part of the NI ELVIS. Refer to the DAQ device documentation, available at [ni.com/manuals](http://ni.com/manuals) for specific information about the functionality and operation of the device.

## DAQ Software

The following sections describe the LabVIEW and SignalExpress software you can use with NI ELVIS

### LabVIEW

LabVIEW is a graphical programming language frequently used for creating test, measurement, and automation applications. LabVIEW uses icons instead of lines of text to create applications. Unlike text-based programming languages, LabVIEW uses dataflow programming, where the flow of data determines execution. A virtual instrument (VI) is a LabVIEW program that models the appearance and function of a physical instrument.

The flexibility, modular nature, and ease-of-use programming possible with LabVIEW makes it popular in top university laboratories. With LabVIEW, you can rapidly create applications using intuitive graphical

development and add user interfaces for interactive control. Scientists and engineers can use the straightforward I/O functionality of LabVIEW along with its analysis capabilities. You can also use LabVIEW in the classroom to solve purely analytical or numerical problems.

For more information about programming with LabVIEW, refer to *Getting Started with LabVIEW* and *LabVIEW Fundamentals*, available at [ni.com/manuals](http://ni.com/manuals). The *LabVIEW Help* is available by selecting **Help»Search the LabVIEW Help** from the LabVIEW block diagram or front panel.

## SignalExpress

SignalExpress is an interactive, standalone nonprogramming tool for making measurements. You can use SignalExpress interactively for the following:

- Acquiring, generating, analyzing, comparing, importing, and saving signals.
- Comparing design data with measurement data in one step.
- Extending the functionality of SignalExpress by importing a custom VI created in LabVIEW or by converting a SignalExpress project to a LabVIEW program so you can continue development in the LabVIEW environment.

For more information about SignalExpress, refer to *Getting Started with SignalExpress*, available at [ni.com/manuals](http://ni.com/manuals), and the *NI Express Workbench Help*, available by selecting **Help»Express Workbench Help** from the SignalExpress window.

## NI ELVIS Overview

---

NI ELVIS uses LabVIEW-based software instruments, a multifunction DAQ device, and a custom-designed benchtop workstation and prototyping board to provide the functionality of a suite of common laboratory instruments.

The NI ELVIS hardware provides a function generator and variable power supplies from the benchtop workstation. The NI ELVIS LabVIEW soft front panel (SFP) instruments combined with the functionality of the DAQ device and the NI ELVIS workstation provide the functionality of the following SFP instruments:

- Arbitrary Waveform Generator (ARB)
- Bode Analyzer

- Digital Bus Reader
- Digital Bus Writer
- Digital Multimeter (DMM)
- Dynamic Signal Analyzer (DSA)
- Function Generator (FGEN)
- Impedance Analyzer
- Oscilloscope (Scope)
- Two-Wire Current Voltage Analyzer
- Three-Wire Current Voltage Analyzer
- Variable Power Supplies

In addition to the SFP instruments, NI ELVIS has a set of high-level LabVIEW functions, which you can use to customize your display and experiments, to control the NI ELVIS workstation from LabVIEW.

With NI ELVIS 3.0 and later, you can control the NI ELVIS instruments in a nonprogramming environment with SignalExpress. In addition to the NI ELVIS instruments, you can also use the general AI, AO, DIO, and CTR functionality available on the NI ELVIS hardware in SignalExpress.

Refer to Figure 2-1, *Parts Locator Diagram for Desktop NI ELVIS Systems*, for an illustration of NI ELVIS.

## Related Documentation

---

The following documents contain information that you might find helpful as you read this manual:

- DAQ device documentation.
- *Getting Started with LabVIEW*.
- *LabVIEW Help*, available by selecting **Help»VI, Function, and How-To Help** from the LabVIEW block diagram or front panel.
- *LabVIEW Fundamentals*.
- *Measurement & Automation Explorer Help for DAQmx*, available by selecting **Help»Help Topics»NI-DAQmx** from the Measurement & Automation Explorer (MAX) window.
- *Where to Start with NI ELVIS*, available in PDF format on the NI ELVIS Software CD.
- *NI ELVIS Help*, available on the NI ELVIS Software CD.

- *Getting Started with SignalExpress.*
- *NI Express Workbench Help*, available by selecting **Help»Express Workbench Help** from the SignalExpress window.
- [ni.com/academic](http://ni.com/academic) for various academic resources.

You can download NI documents from [ni.com/manuals](http://ni.com/manuals).

# NI ELVIS Overview

NI ELVIS combines hardware and software into one complete laboratory suite. This chapter provides an overview of the hardware and software components of the NI ELVIS. Additionally, this chapter discusses how you can use NI ELVIS in various academic environments.

Chapter 3, *Hardware Overview*, provides more detailed information about NI ELVIS hardware components. Refer to the *NI ELVIS Help* for more information about the software components.

Refer to Figures 2-1 and 2-2 for a diagram of the NI ELVIS systems.

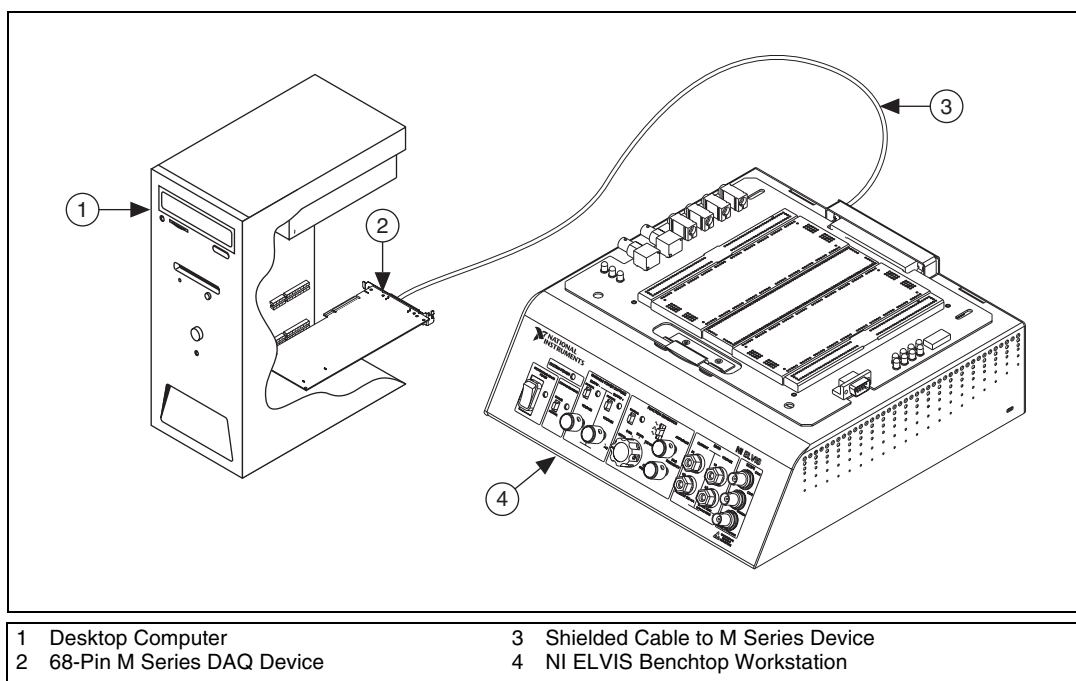

**Figure 2-1.** Parts Locator Diagram for Desktop NI ELVIS Systems

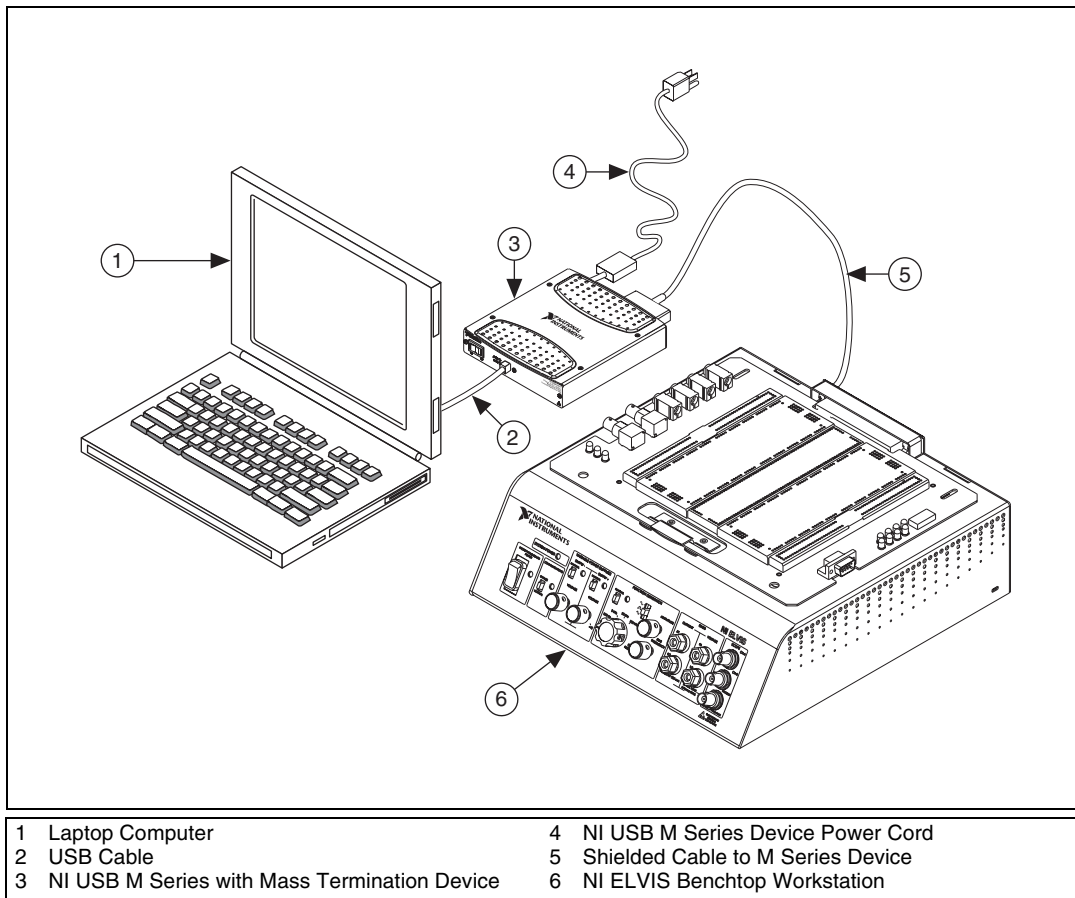

**Figure 2-2.** Parts Locator Diagram for USB NI ELVIS Systems

## NI ELVIS Hardware

The following sections briefly describe the hardware components of NI ELVIS. For more specific information about these components, refer to Chapter 3, [Hardware Overview](#).

### NI ELVIS Benchtop Workstation

Together, the benchtop workstation and the DAQ device create a complete laboratory system. The workstation provides connectivity and functionality. The workstation control panel provides easy-to-operate knobs for the function generator and variable power supplies, and it offers convenient connectivity in the form of BNC and banana-style connectors



to the NI ELVIS - Scope and NI ELVIS - DMM. The NI ELVIS software routes signals in the NI ELVIS Benchtop Workstation between the SFP instruments. For example, you can route the output of the function generator to a specific channel of the DAQ device and ultimately acquire data on a desired channel of the NI ELVIS - Scope. The benchtop workstation also contains a protection board that protects the DAQ device from possible damage resulting from laboratory errors.

Refer to the *NI ELVIS Benchtop Workstation* section of Chapter 3, *Hardware Overview*, for more detailed information about the benchtop workstation, including the parts locator diagram.

## NI ELVIS Prototyping Board

The NI ELVIS Prototyping Board connects to the benchtop workstation. The prototyping board provides an area for building electronic circuitry and allows the connections necessary to access signals for common applications. You can use multiple prototyping boards interchangeably with the NI ELVIS Benchtop Workstation.

Refer to the *NI ELVIS Prototyping Board* section of Chapter 3, *Hardware Overview*, for more information about the prototyping board, including signal descriptions, connection instructions, and the parts locator diagram.

## NI ELVIS Software

---

The NI ELVIS software, created in LabVIEW, takes advantage of the capabilities of virtual instrumentation. The software includes SFP instruments, the LabVIEW API, and SignalExpress blocks for programming the NI ELVIS hardware.

## SFP Instruments

NI ELVIS ships with the SFP instruments, created in LabVIEW, and the source code for the instruments. You cannot directly modify the executable files, but you can modify or enhance the functionality of these instruments by modifying the LabVIEW code. The instruments are virtual instruments (VIs) that are necessary in typical laboratory applications.



**Note** For a detailed explanation of the SFP instruments and instructions for taking a measurement with each instrument, refer to the *NI ELVIS Help*.

## Instrument Launcher

The NI ELVIS Instrument Launcher provides access to the NI ELVIS SFP instruments. Launch the NI ELVIS Instrument Launcher by double-clicking the NI ELVIS desktop icon or navigate to **Start»All Program Files»National Instruments»NI ELVIS 3.0»NI ELVIS**. After initializing, the suite of LabVIEW SFP instruments opens.

To launch an instrument, click the button corresponding to the desired instrument. If the NI ELVIS software is properly configured and the benchtop workstation is cabled to the appropriate DAQ device, all buttons should be enabled.

If there is a problem with your configuration, such as when the NI ELVIS Benchtop Workstation is powered off or disconnected from the configured DAQ device, all instrument buttons are dimmed, and the only available option is to click the **Configure** button. Refer to the *Where to Start with NI ELVIS* document for more information about configuring NI ELVIS.

Some instruments perform similar operations using the same resources of the NI ELVIS hardware and the DAQ device, and therefore cannot run at the same time. If you launch two instruments with overlapping functionality that cannot run at the same time, the NI ELVIS software generates an error dialog describing the conflict. The instrument with the error is disabled and will not function until the conflict is resolved. Refer to Appendix D, *Resource Conflicts*, for more information about possible resource conflicts.

## Arbitrary Waveform Generator (ARB)

This advanced-level SFP instrument uses the AO capabilities of the DAQ device. You can create a variety of signal types using the Waveform Editor software, which is included with the NI ELVIS software. You can load waveforms created with the NI Waveform Editor into the ARB SFP to generate stored waveforms. Refer to the *NI ELVIS Help* for more information about the Waveform Editor.

Because a typical DAQ device has two AO channels, two waveforms may be simultaneously generated. You can choose continuous output or a single output. The maximum output rate of the NI ELVIS - ARB SFP is determined by the maximum update rate of the DAQ device connected to the NI ELVIS hardware. Refer to the DAQ device documentation for these specifications.

## Bode Analyzer

By combining the frequency sweep feature of the function generator and the AI capability of the DAQ device, a full-function Bode Analyzer is available with NI ELVIS. You can set the frequency range of the instrument and choose between linear and logarithmic display scales. Refer to the NI ELVIS Help for required hardware connections.

## Digital Bus Reader

This instrument reads digital data from the NI ELVIS digital input (DI) bus. You can either continuously read from the bus or you can take a single reading.

## Digital Bus Writer

This instrument updates the NI ELVIS digital output (DO) bus with user-specified digital patterns. You can manually create a pattern or select predefined patterns, such as ramp, toggle, or walking 1s. This instrument can either continually output a pattern or just perform a single write. The output of the NI ELVIS - Digital Bus Writer SFP stays latched until the instrument is stopped or another pattern is output. Output voltage levels of the NI ELVIS DO bus are TTL compatible.

## Digital Multimeter (DMM)

This commonly used instrument can perform the following types of measurements:

- DC voltage
- AC voltage
- Current (DC and AC)
- Resistance
- Capacitance
- Inductance
- Diode test
- Audible continuity

You can connect to the DMM from the NI ELVIS Prototyping Board or from the banana-style connectors on the front panel of the benchtop workstation.

## Dynamic Signal Analyzer (DSA)

This instrument is especially useful in advanced electrical engineering and physics classes. This instrument uses the analog input of the DAQ device to make measurements, and can either continuously make measurements or make a single scan. You can also apply various window and filtering options to the signal.

## Function Generator (FGEN)

This instrument provides you with choices for the type of output waveform (sine, square, or triangle), amplitude selection, and frequency settings. In addition, the instrument offers DC offset setting, frequency sweep capabilities, and amplitude and frequency modulation.

## Impedance Analyzer

This instrument is a basic impedance analyzer that is capable of measuring the resistance and reactance for passive two-wire elements at a given frequency.

## Oscilloscope (Scope)

This instrument provides the functionality of the standard desktop oscilloscope found in typical undergraduate laboratories. The NI ELVIS - Scope SFP has two channels and provides scaling and position adjustment knobs along with a modifiable timebase. You can also choose trigger source and mode settings. The autoscale feature allows you to adjust the voltage display scale based on the peak-to-peak voltage of the AC signal for the best display of the signal. Depending on the DAQ device cabled to the NI ELVIS hardware, you can choose between digital or analog hardware triggering. You can connect to the NI ELVIS - Scope SFP from the NI ELVIS Prototyping Board or from the BNC connectors on the front panel of the benchtop workstation.

The FGEN or DMM signals can be internally routed to this instrument. In addition, this computer-based scope display has the ability to use cursors for accurate screen measurements. The sampling rate of the Oscilloscope is determined by the maximum sampling speed of the DAQ device installed in the computer attached to the NI ELVIS hardware.

Refer to the DAQ device documentation for information about the type of triggering supported on the device and for the maximum sampling speed specifications of the device.

## Two-Wire and Three-Wire Current-Voltage Analyzers

These instruments allow you to conduct diode and transistor parametric testing and view current-voltage curves. The two-wire instrument offers full flexibility in setting parameters such as voltage and current ranges, and can save data to a file. In addition, the three-wire instrument offers base current settings for measurements of NPN transistors. Refer to *NI ELVIS Help* for connection details. Both instruments have cursors for more accurate onscreen measurements.

## Variable Power Supplies

You can control the output of the positive or negative variable power supply with these SFP instruments. The negative power supply can output between  $-12$  and  $0$  V, and the positive power supply can output between  $0$  and  $+12$  V.

## Using NI ELVIS with LabVIEW









This section provides an overview of using NI ELVIS with LabVIEW.

### LabVIEW Express VIs

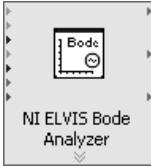
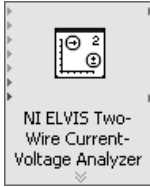
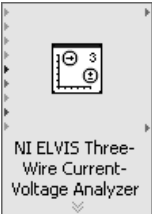
When using NI ELVIS 3.0 or later, many of the NI ELVIS instruments have an associated LabVIEW Express VI. The Express VIs are the recommended method for programming NI ELVIS in LabVIEW. Express VIs allow you to interactively configure the settings for each instrument. This enables you to develop LabVIEW applications without extensive programming expertise. To access the NI ELVIS Express VIs, open a LabVIEW block diagram and select **Instrument I/O»Instrument Drivers»NI ELVIS** from the function palette.

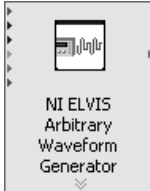
Table 2-1 shows the available NI ELVIS Express VIs. Refer to the *NI ELVIS Help* for more information.

**Table 2-1.** NI ELVIS Express VIs

<b>NI ELVIS Express VI</b>			
 <p>NI ELVIS Oscilloscope</p>	 <p>NI ELVIS Digital Multimeter</p>	 <p>NI ELVIS Bode Analyzer</p>	 <p>NI ELVIS Two-Wire Current-Voltage Analyzer</p>
 <p>NI ELVIS Three-Wire Current-Voltage Analyzer</p>	 <p>NI ELVIS Impedance Analyzer</p>	 <p>NI ELVIS Variable Power Supplies</p>	 <p>NI ELVIS Arbitrary Waveform Generator</p>
 <p>NI ELVIS Function Generator</p>	 <p>NI ELVIS Digital Reader</p>	 <p>NI ELVIS Digital Writer</p>	<p>—</p>

## Low Level NI ELVIS API

Before the NI ELVIS Express VIs were created, the API consisted of the NI ELVIS instrument driver VIs, now referred to as the Low Level NI ELVIS API, which enabled you to programming the following components:

- Digital I/O (DIO)
- Digital Multimeter (DMM)
- Function Generator (FGEN)
- Variable Power Supplies (VPS)
- Communication Bypass

The NI ELVIS Express VIs expose all of the functionality for each instrument and are the recommended method for programming NI ELVIS in LabVIEW. The Low Level NI ELVIS VIs are included to provide backwards compatibility for NI ELVIS applications written previous to NI ELVIS 3.0. Refer to the *NI ELVIS Help* for more information about using the Low Level API to program NI ELVIS.

## Using NI-DAQmx with NI ELVIS

Some general AI, AO, and timing functionality of the DAQ device is available through the NI ELVIS workstation and you can program it using NI-DAQmx. Refer to *NI ELVIS Help* and *NI-DAQmx Help* for more information.

## Using NI ELVIS in SignalExpress

To use an NI ELVIS instrument within SignalExpress complete the following steps:

1. Launch SignalExpress.
1. Click the **Add Step** button.
2. If NI ELVIS 3.0 or later is installed, NI ELVIS is in the list of steps. Expand NI ELVIS.
3. Choose the instrument to add under **Analog** or **Digital»Acquire** or **Generate Signals**.
4. Click the **Configure** button to select the DAQ device cabled to the NI ELVIS Benchtop Workstation.
5. Set the various controls on the configuration panel appropriately for the measurement.
6. Run the SignalExpress project.

For more information about using NI ELVIS with SignalExpress, refer to the *NI SignalExpress Workbench Help*, which you can find through the Help menu in SignalExpress.

For more information about SignalExpress, refer to the *Getting Started with SignalExpress Guide*.

## NI ELVIS Calibration Utility

The NI ELVIS 2.0 or later software includes a calibration utility that you can use to recalibrate the NI ELVIS variable power supplies and function generator circuitry.

# NI ELVIS in Academic Disciplines

---

You can use NI ELVIS in engineering, physical sciences, and biological sciences laboratories. NI ELVIS is suitable not only in terms of the included software, but also because of the custom signal conditioning hardware you can create with NI ELVIS. Instructors can implement the NI ELVIS curriculum with beginning to advanced classes to provide hands-on experience to students.

## NI ELVIS in Engineering

NI ELVIS is suited for teaching basic electronics and circuit design to students in electrical engineering, mechanical engineering, and biomedical engineering. The suite offers full testing, measurement, and data-saving capabilities needed for such training. Students can use the removable prototyping board at home to build circuits, thus using laboratory time more effectively.

NI ELVIS SFP instruments, such as the Bode Analyzer, offer instructors an opportunity to teach advanced courses in signal analysis and processing. Students can construct software filters in LabVIEW and hardware filters on the prototyping board and compare the performance of those two types of filters.

Mechanical engineering students can learn sensor and transducer measurements in addition to basic circuit design by building custom signal conditioning. Students can install custom sensor adapters on the prototyping board. For example, installing a thermocouple jack on the prototyping board allows robust thermocouple connections. The programmable power supply can provide excitation for strain gauges used in strain measurements.

## NI ELVIS in Biological Sciences



**Caution** The NI ELVIS hardware is *not* environmentally sealed; therefore, exercise caution for use in chemical and biological sciences.

Biomedical engineering departments have challenges that are similar to those of mechanical departments. Students typically learn basic electronics and build instruments such as an electrocardiogram (ECG) monitor. The prototyping board offers signal conditioning capability for ECG sensors, and the NI ELVIS SFP instruments are ideal for testing the circuits as students build the signal conditioning circuits.



## NI ELVIS in Physical Sciences

Physics students typically learn electronics and circuit design theory. NI ELVIS provides these students with the opportunity to implement these concepts. Physics students sometimes need signal conditioning for common sensors such as photoelectric multipliers or light detector sensors. Students can build high-gain, low-noise circuits on the removable printed circuit board (PCB) and study them in modern physics labs.

---

# Hardware Overview

This chapter describes the hardware components of NI ELVIS, including the DAQ device, the benchtop workstation, and the prototyping board. Appendix C, *Theory of Operation*, provides more information about the circuitry used for the different NI ELVIS measurements.

## DAQ Hardware

---

The NI ELVIS workstation is designed to work with National Instruments M Series DAQ devices, which are high-performance, multifunction analog, digital, and timing I/O devices for PCI bus computers. Supported functions on DAQ devices include AI, AO, DIO, and timing I/O (TIO).

### Recommended DAQ Devices

NI ELVIS software version 3.0 and later is recommended for use with the following DAQ devices:

- NI PCI-6251 M Series DAQ device
- NI USB-6251 Mass Termination M Series DAQ device



**Note** For a complete list of other supported DAQ devices, refer to Appendix E, *Supported DAQ Devices*.

Use one of the following cables to connect the NI ELVIS workstation:

- PCI M Series DAQ device:
  - SHC68-68-EPM
  - SHC68-68
  - RC68-68
- NI USB 6251 mass termination device:
  - SH68-68-EP

# NI ELVIS Benchtop Workstation



**Caution** Refer to the *Read Me First: Safety and Radio-Frequency Interference* document before removing equipment covers, or connecting or disconnecting any signal wires.

This section describes the NI ELVIS Benchtop Workstation.

Refer to Figure 3-1 for the parts locator diagram for the control panel.

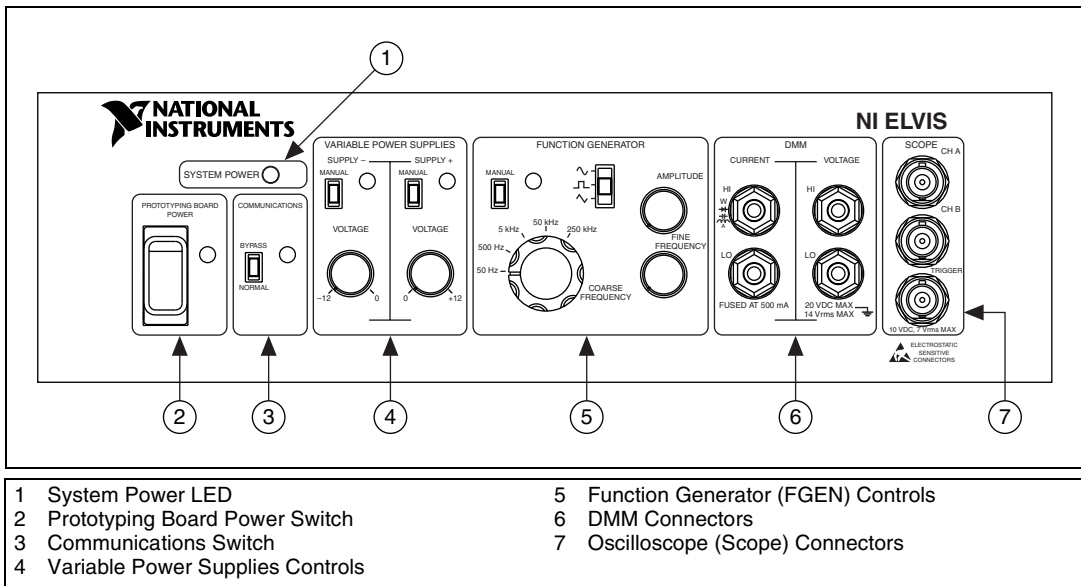

**Figure 3-1.** Control Panel Diagram of the Benchtop Workstation

The benchtop workstation has the following controls and indicators:

- **System Power LED**—Indicates whether the NI ELVIS is powered on.
- **Prototyping Board Power Switch**—Controls the power to the prototyping board.
- **Communications Switch**—Requests disabling software control of the NI ELVIS. In most applications set this switch to *Normal* to enable the computer to control NI ELVIS. For more information about the Communications switch, refer to Appendix F, [Using Bypass Communication Mode](#).

- **Variable Power Supplies Controls**
  - **Supply– Controls**
    - **Manual Switch**—Controls whether the negative supply is in Manual mode or Software mode. In Manual mode, the voltage knob controls the negative power supply. In Software mode, the Variable Power Supply SFP controls the negative power supply.
    - **Voltage Adjust Knob**—Controls the output of the negative supply. The negative supply can output between  $-12$  and  $0$  V. You must set the Manual switch to Manual mode to use this knob.
  - **Supply+ Controls**
    - **Manual Switch**—Controls whether the positive supply is in Manual mode or Software mode. In Manual mode, the voltage knob controls the positive power supply. In Software mode, the Variable Power Supply SFP controls the positive power supply.
    - **Voltage Adjust Knob**—Controls the output of the positive supply. The positive supply can output between  $0$  and  $+12$  V. You must set the Manual switch to Manual mode to use this knob.

For more information about the software controls for the NI ELVIS - Variable Power Supplies SFP, refer to the *NI ELVIS Help*.

- **Function Generator Controls**
  - **Manual Switch**—Controls whether the function generator is in Manual mode or Software mode.
    - In Manual mode, the Function Selector, Amplitude Knob, Coarse Frequency Knob, and Fine Frequency Knob controls the function generator.
    - In Software mode, the FGEN SFP controls the Function Generator.
  - **Function Selector**—Selects what type of waveform is generated. NI ELVIS can generate sine, square, or triangle waves.
  - **Amplitude Knob**—Adjusts the peak amplitude of the generated waveform.
  - **Coarse Frequency Knob**—Sets the range of frequencies the function generator can generate.
  - **Fine Frequency Knob**—Adjusts the output frequency of the function generator.

For more information about the software controls for the function generator, refer to the *NI ELVIS Help*.

- **DMM Connectors**
  - **CURRENT Banana Jacks**
    - **HI**—The positive input to all the DMM functionality, except measuring voltage.
    - **LO**—The negative input to all the DMM functionality, except measuring voltage.
  - **VOLTAGE Banana Jacks**
    - **HI**—The positive input for voltage measurements.
    - **LO**—The negative input for voltage measurements.

If you use the front panel DMM inputs, do not use the DMM inputs on the prototyping board.



**Caution** By connecting different signals to both the DMM terminals on the prototyping board and the DMM connectors on the control panel, you are shorting them together, potentially damaging the circuit on the prototyping board.



**Note** The NI ELVIS DMM is ground referenced.

- **Oscilloscope (Scope) Connectors**
  - **CH A BNC Connector**—The input for channel A of the Oscilloscope.
  - **CH B BNC Connector**—The input for channel B of the Oscilloscope.
  - **Trigger BNC Connector**—The input to the trigger of the Oscilloscope.

If you use the front panel scope inputs, do not use the scope inputs on the prototyping board.



**Caution** By connecting different signals to the Scope terminals on the prototyping board and the Scope connectors on the control panel, you are shorting them together, potentially damaging the circuit on the prototyping board.

## NI ELVIS Rear Panel

The NI ELVIS rear panel has the following components shown in Figure 3-2:

- The workstation power switch. Use this switch to completely power off the workstation.
- An AC–DC power supply connection. Use this connector to power the workstation.
- A 68-pin DAQ device connection. Use this connector to attach the DAQ device to the workstation.

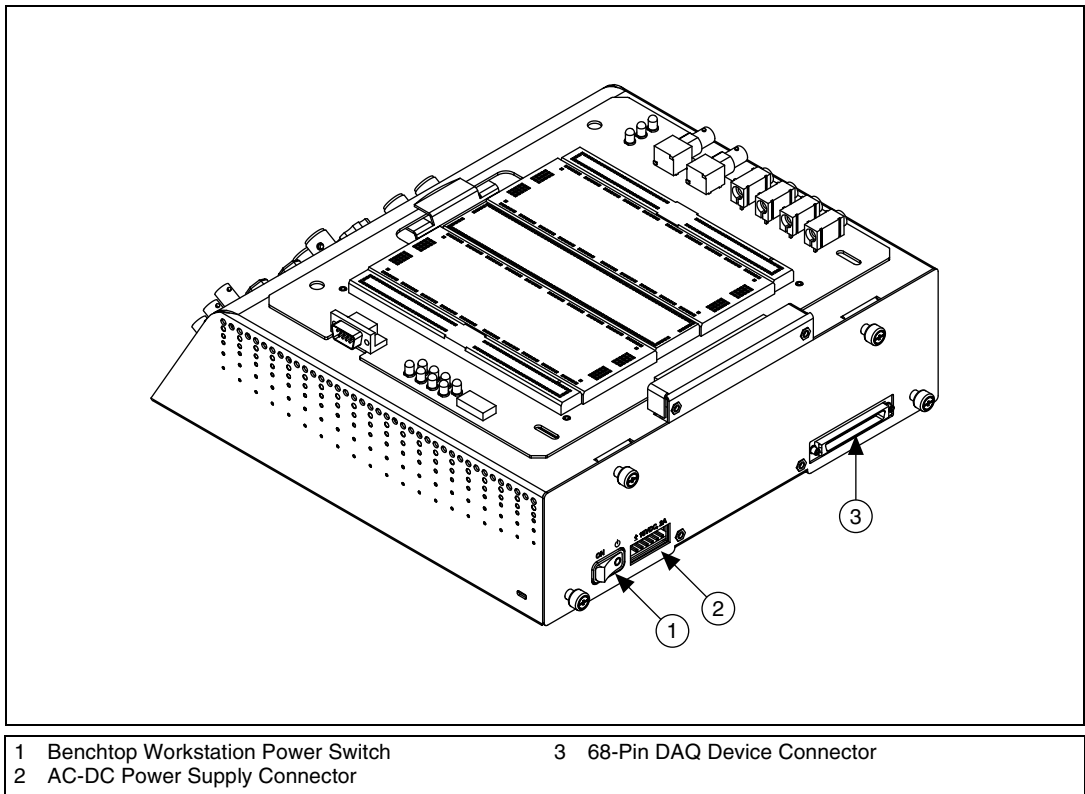

**Figure 3-2.** Back View of NI ELVIS Benchtop Workstation

## NI ELVIS Protection Board

NI ELVIS protects the DAQ device installed in the desktop computer by means of a protection board located inside the NI ELVIS Benchtop Workstation. This removable protection board provides short-circuit protection from unsafe external signals. Removing the protection board enables you to quickly replace a nonfunctioning board with a replacement unit. You can obtain the components on the protection board from electronics vendors and therefore service the protection board without sending it to NI for repairs.

Refer to Appendix B, *Protection Board Fuses*, for more information about replacing the fuses on the NI ELVIS Protection Board.

## NI ELVIS Prototyping Board

---

This section describes the NI ELVIS Prototyping Board and how you can use it to connect circuits to NI ELVIS. This section also describes the signals that you can connect to NI ELVIS from the prototyping board and the connectors you can use to do so.



**Caution** Ensure the power to the prototyping board power switch is off before inserting the prototyping board into the NI ELVIS Benchtop Workstation.

You can use the prototyping board connector to install custom prototype boards you develop. This connector is mechanically the same as a standard PCI connector.

The prototyping board exposes all the signal terminals of the NI ELVIS for use through the distribution strips on either side of the breadboard area. Each signal has a row, and the rows are grouped by function.

Refer to Figure 3-3 for the parts locator diagram for the prototyping board.

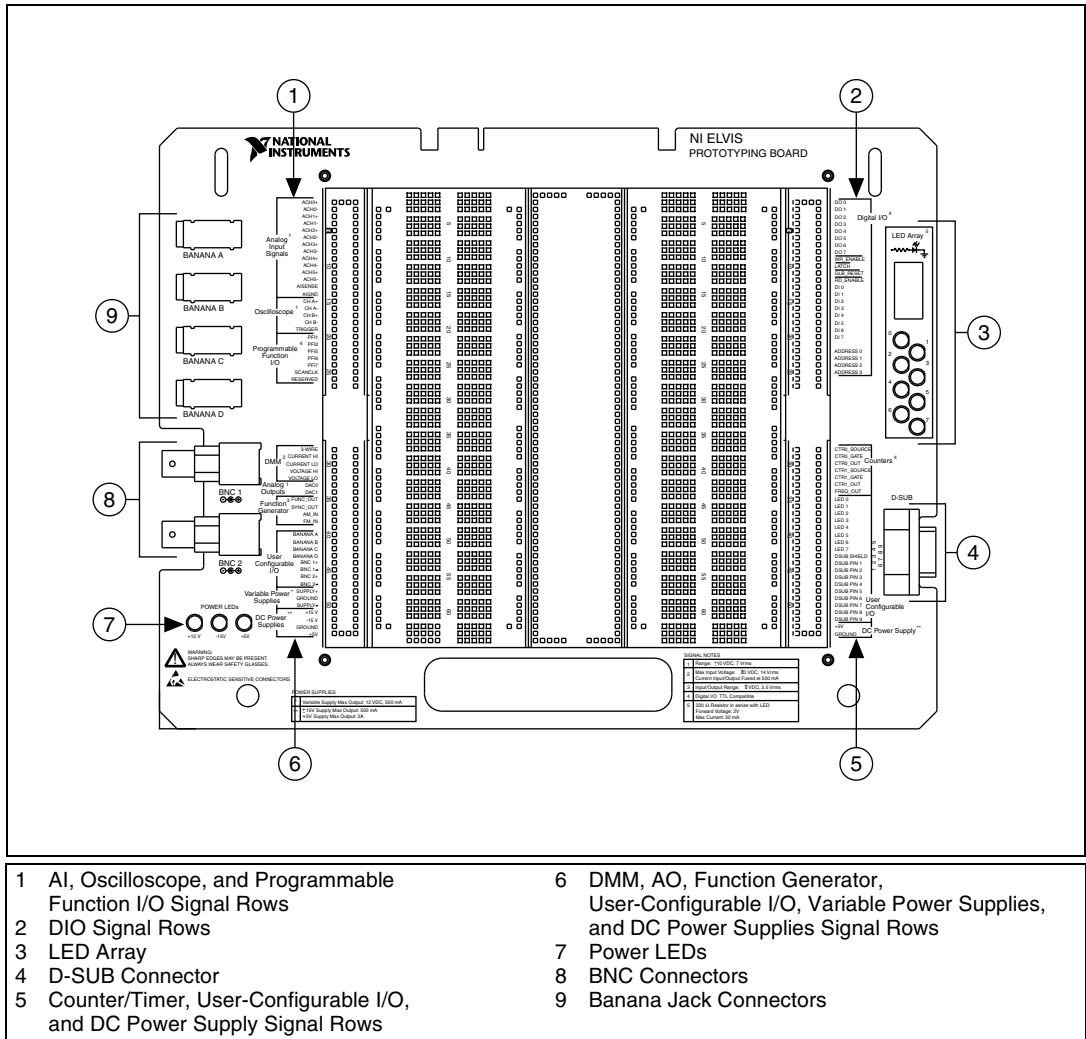

Figure 3-3. Prototyping Board Parts Locator Diagram

## Prototyping Board Power

The prototyping board provides access to a  $\pm 15\text{ V}$  and a  $+5\text{ V}$  power supply. You can use these voltage rails to construct many common circuits. Refer to Appendix A, *Specifications*, for more information about these voltage rails. If any of the power LEDs are not lit when the prototyping board power is enabled, refer to Appendix B, *Protection Board Fuses*, for details about replacing NI ELVIS fuses.



## Prototyping Board Signal Descriptions

Tables 3-1 and 3-2 describe the signals on the NI ELVIS prototyping board. The signals are grouped by the functionality section where they are located on the prototyping board.

**Table 3-1.** Signal Descriptions

Signal Name	Type	Description
ACH <0..2> ±	General AI	Analog Input Channels 0 through 2 ±—Positive and negative input channels to differential AI channel.
ACH <3,4> ±	General AI	Analog Input Channels 3 and 4 ±—Positive and negative input channels to differential AI channel. If you are using the oscilloscope, you cannot use ACH <3,4> ±.
ACH 5 ±	General AI	Analog Input Channel 5±—Positive and negative input channel to differential AI channel. If you are using the DMM, you cannot use ACH 5±.
AI SENSE	General AI	Analog Input Sense—Reference for the analog channels in nonreferenced single-ended (NRSE) mode. For more information about AI modes, refer to the DAQ device documentation.
AI GND	General AI	Analog Input Ground—AI ground reference for the DAQ device. This ground signal is not connected to the NI ELVIS GROUND signals.
CH <A..B>+	Oscilloscope	Oscilloscope Channels A and B (+)—Positive input for the Oscilloscope channels.
CH <A..B>-	Oscilloscope	Oscilloscope Channels A and B (—)—Negative input for the Oscilloscope channels.
TRIGGER	Oscilloscope	Oscilloscope Trigger—Trigger input for the Oscilloscope, referenced to AI GND.
3-WIRE	DMM	Three Wire—Voltage source for the DMM for three-wire transistor measurements.
CURRENT HI	DMM	Positive Current—Positive input for the DMM for all measurements besides voltage. The NI ELVIS is ground referenced.
CURRENT LO	DMM	Negative Current—Negative input for the DMM for all measurements besides voltage. The NI ELVIS is ground referenced.
VOLTAGE HI	DMM	Positive Voltage—Positive input for the DMM voltmeter.
VOLTAGE LO	DMM	Negative Voltage—Negative input for the DMM voltmeter.
DAC<0..1>	Analog Outputs	Analog Output Channels 0 and 1—For more information about the DAQ device analog output signals, refer to the <i>M Series Help</i> and Appendix C, <i>Theory of Operation</i> .

**Table 3-1.** Signal Descriptions (Continued)

Signal Name	Type	Description
FUNC_OUT	Function Generator	Function Output—Output of the function generator.
SYNC_OUT	Function Generator	Synchronization Output—TTL signal of the same frequency as the signal on the FUNC_OUT pin.
AM_IN	Function Generator	Amplitude Modulation Input—Input to the amplitude modulator for the function generator.
FM_IN	Function Generator	Frequency Modulation Input—Input to the frequency modulator for the function generator.
BANANA <A..D>	User Configurable I/O	Banana Jacks A through D—Connects to the banana jacks pins.
BNC <1..2>+	User Configurable I/O	BNC Connectors 1 and 2 (+)—Connects to the BNC pins.
BNC <1..2>-	User Configurable I/O	BNC Connectors 1 and 2 (—)—Connects to the BNC pins.
SUPPLY+	Variable Power Supplies	Positive—Output of 0 to 12 V variable power supply.
GROUND	Variable Power Supplies	Ground—Prototyping board ground. These ground pins are connected together.
SUPPLY-	Variable Power Supplies	Negative—Output of -12 to 0 V variable power supply.
+15 V	DC Power Supplies	+15 V Source—Output of fixed +15 V power supply, referenced to the GROUND signal.
-15 V	DC Power Supplies	-15 V Source—Output of fixed -15 V power supply, referenced to the GROUND signal.
GROUND	DC Power Supplies	Ground—Prototyping board ground. These ground pins are connected together.
+5V	DC Power Supplies	+5V Source—Output of fixed +5 V power supply, referenced to the GROUND signal.
DO <0..7>	DIO	Digital Output Lines 0 through 7—Output of the write bus. These channels are used by the NI ELVIS Digital Bus Writer SFP to generate digital data.
WR ENABLE	DIO	Write Enable—Active low signal that updates when DO <0..7> are updated.
LATCH	DIO	Latch—Active low signal that pulses when data is ready on DO <0..7>.
GLB RESET	DIO	Global Reset—Active low signal that is used to reset all of the NI ELVIS hardware settings.
RD ENABLE	DIO	Read Enable—Active low signal that indicates data is being read from DI <0..7>.

**Table 3-1.** Signal Descriptions (Continued)

Signal Name	Type	Description
DI <0..7>	DIO	Digital Input Lines 0 through 7—Input to read bus. These channels are used by the NI ELVIS Digital Bus Reader SFP to acquire digital data.
ADDRESS <0..3>	DIO	Address Lines 0 through 3—Output of address bus.
LED <0..7>	User-Configurable I/O	LEDs 0 through 7—Input to the LEDs.
DSUB SHIELD	User-Configurable I/O	D-SUB Shield—Connection to D-SUB shield.
DSUB PIN <1..9>	User-Configurable I/O	D-SUB Pins 1 through 9—Connection to D-SUB pins.
+5 V	DC Power Supply	+5V Source—Output of fixed +5 V power supply, referenced to the GROUND signal.
GROUND	DC Power Supply	Ground—Prototyping board ground. These ground pins are connected together.

The NI ELVIS prototype board includes signals that route directly to the M Series DAQ device. Table 3-2 describes these signals.

**Table 3-2.** M Series DAQ Device Routing

Signal Name on Prototype Board	Direction <sup>1</sup>	M Series Signal Name	Description <sup>2</sup>
PFI 1	Input	PFI 1/P1.1	PFI Input or Static Digital Input
PFI 2	Input	PFI 2/P1.2	PFI Input or Static Digital Input
PFI 5	Input	PFI 5/P1.5	PFI Input or Static Digital Input
PFI 6	Input	PFI 6/P1.6	PFI Input or Static Digital Input
PFI 7	Input	PFI 7/P1.7	PFI Input or Static Digital Input
SCANCLK	Output	PFI 11/P2.3	PFI Output or Static Digital Output
RESERVED	Output	PFI 10/P2.2	PFI Output or Static Digital Output
CTR0_SOURCE	Input	PFI 8/P2.0	PFI Input or Static Digital Input (Defaults to CTR 0 SRC in NI-DAQmx)
CTR0_GATE	Input	PFI 9/P2.1	PFI Input or Static Digital Input (Defaults to CTR 0 GATE in NI-DAQmx)
CTR0_OUTPUT	Output	PFI 12/P2.4	PFI Output or Static Digital Output (Defaults to CTR 0 OUT in NI-DAQmx)

**Table 3-2.** M Series DAQ Device Routing (Continued)

Signal Name on Prototype Board	Direction <sup>1</sup>	M Series Signal Name	Description <sup>2</sup>
CTR1_SOURCE	Input	PFI 3/P1.3	PFI Input or Static Digital Input (Defaults to CTR 1 SRC in NI-DAQmx)
CTR1_GATE	Input	PFI 4/P1.4	PFI Input or Static Digital Input (Defaults to CTR 1 GATE in NI-DAQmx)
CTR1_OUTPUT	Output	PFI 13/P2.5	PFI Output or Static Digital Output (Defaults to CTR 1 OUT in NI-DAQmx)
FREQ_OUT	Output	PFI 14/P2.6	PFI Output or Static Digital Output
<p><sup>1</sup> On M Series DAQ devices, you can configure all of these signals as inputs or output; however, when used with the NI ELVIS workstation, these signals are fixed direction—either input or output.</p> <p><sup>2</sup> Refer to the <a href="#">PFI Signal Descriptions</a> section and the M Series DAQ device Help for more complete descriptions of these signals.</p>			



**Note** Refer to Appendix E, [Supported DAQ Devices](#), for E Series DAQ device signal descriptions.

## PFI Signal Descriptions

**PFI Input or Static Digital Input** – As a PFI input, you can use these signals to supply an external source for AI, AO, DI, and DO timing signals or counter/timer inputs. You can also use these signals as static digital inputs (port 1 or port 2).

**PFI Output or Static Digital Output** – As a PFI output, you can route many different internal AI, AO, DI, or DO timing signals to each PFI output. You also can route the counter/timer outputs to each PFI output. You can also use these signals as static digital outputs (port 1 or port 2).

## Connecting Signals

This section provides information about connecting signals between the NI ELVIS and the DAQ device. Refer to Appendix D, [Resource Conflicts](#), for a table showing possible resource conflicts when connecting NI ELVIS signals.



**Caution** Refer to the *Read Me First: Safety and Radio-Frequency Interference* document before removing equipment covers, or connecting or disconnecting any signal wires.

## Grounding Considerations

Because the analog channels are differential, you must establish a ground point somewhere in the signal path. As long as the signal you are measuring is referenced to one of the NI ELVIS GROUND pins, the measurement is correctly referenced. If a floating source, such as a battery, is being measured, be sure to connect one end of the signal to the NI ELVIS GROUND. Terminals for the NI ELVIS GROUND signal are located at several locations on the prototyping board. All these signals are connected together.

## Connecting Analog Input Signals

This section describes how to connect AI signals on the NI ELVIS Prototyping Board. Refer to the DAQ device documentation for more information about types of signal sources, input modes, grounding configurations, and floating signal sources.

### Generic Analog Input

The NI ELVIS Prototyping Board has six differential AI channels available—ACH<0..5>. These inputs are directly connected to the DAQ device input channels. The NI ELVIS prototyping board also exposes two ground reference pins, AI SENSE and AI GND, which are connected to the M Series DAQ device. Table 3-3 shows how the NI ELVIS input channels map to the DAQ device input channels.

**Table 3-3.** Analog Input Signal Mapping

NI ELVIS Input Channel	DAQ Device Input Channel
ACH0+	AI 0
ACH0–	AI 8
ACH1+	AI 1
ACH1–	AI 9
ACH2+	AI 2
ACH2–	AI 10
ACH3+	AI 3
ACH3–	AI 11
ACH4+	AI 4

**Table 3-3.** Analog Input Signal Mapping (Continued)

NI ELVIS Input Channel	DAQ Device Input Channel
ACH4-	AI 12
ACH5+	AI 5
ACH5-	AI 13
AISENSE	AI SENSE
AIGND	AI GND

The following sections describe some special considerations for connecting the AI signals on the prototyping board, including sections that specifically pertain to the Oscilloscope and DMM.

## Resource Conflicts

Some of the AI channels are used by the internal circuitry for other instruments, but the majority of the time you can still use the channel. You can use ACH<0..2> without interruption. ACH5 is interrupted if any of the impedance-analyzing capabilities of the DMM, such as the capacitance meter, diode tester, and so on, are used. If you are using the Oscilloscope, disconnect any signals from ACH3 and ACH4 to avoid double-driving the channels. For more information about possible resource conflicts, refer to Appendix D, *Resource Conflicts*. Refer to Table 3-4 for AI channel resource conflicts.

**Table 3-4.** AI Channel Resource Conflicts

AI Channel	Conflict
0	None
1	None
2	None
3	Oscilloscope CH A
4	Oscilloscope CH B
5	DMM (Capacitor, Diode Tester)

## DMM

Both the CURRENT and VOLTAGE inputs are available on the prototyping board along with an additional terminal for three-wire transistor measurements. The differential voltmeter inputs are labeled VOLTAGE HI and VOLTAGE LO. The rest of the functionality of the DMM is available through the CURRENT HI and CURRENT LO pins. The 3-WIRE pin is used for three-terminal device measurements in conjunction with the CURRENT HI and CURRENT LO pins. If you are using the DMM, you cannot use ACH 5.



**Caution** By connecting different signals to both the DMM terminals on the prototyping board and the DMM connectors on the control panel, you are shorting them together, potentially damaging the circuit on the prototyping board.

## Oscilloscope

The inputs of the Oscilloscope are available on the prototyping board as CH <A..B>+, CH <A..B>-, and TRIGGER. CH <A..B> are directly connected to ACH3 and ACH4, respectively, on the DAQ device. If you are using the scope, you cannot use ACH 3 and 4.



**Caution** By connecting different signals to the Scope terminals on the prototyping board and the Scope connectors on the control panel, you are shorting them together, potentially damaging the circuit on the prototyping board.

## Connecting Analog Output Signals

This section describes how to connect the AO signals on the prototyping board.

### Generic Analog Output

NI ELVIS provides access to the two analog outputs from the DAQ device at the DAC0 and DAC1 terminals. These channels are used by the NI ELVIS hardware for arbitrary waveform generation. The output of the DAQ device is buffered and protected by the NI ELVIS hardware.



**Caution** Other functions of NI ELVIS, such as the DMM and FGEN, internally use DAC0 and DAC1, and these functions can potentially interfere with the measurements. The driver software generates an error message when there is a potential resource conflict.

## DC Power Supplies

The DC power supplies output a static  $\pm 15$  V and +5 V. For more information about the DC power supplies output, refer to Appendix A, *Specifications*.

## Function Generator (FGEN)

Access to the function generator on the prototyping board includes several additional terminals besides the function generator output signal, FUNC\_OUT. The SYNC\_OUT signal outputs a TTL-compatible clock signal of the same frequency as the output waveform. The AM\_IN and FM\_IN signals control the amplitude modulation (AM) and the frequency modulation (FM), respectively. Leave FM\_IN and AM\_IN disconnected if you do not want to apply modulation to the FGEN signal. These signals are in addition to the fine frequency and amplitude controls on the benchtop workstation. Software AM is controlled by DAC0 and software FM is controlled by DAC1.

## Variable Power Supplies

The variable power supplies provide adjustable output voltages from 0 to +12 V on the SUPPLY+ terminal and -12 to 0 V on the SUPPLY- terminal. The GROUND pin provides a connection to the same ground of the DC power supplies.

## Bode Analyzer

The NI ELVIS Bode Analyzer uses the Function Generator to output a stimulus and then uses analog input channels ACH 0 and ACH 1 to measure the stimulus and response. On the prototyping board, connect FUNC\_OUT to the input of the circuit and ACH 1. Connect the output to ACH 0.

## Two-Wire Current-Voltage Analyzer

Connect the signal to Current Hi and Current Low when using the Two-Wire Current-Voltage Analyzer.



## Three-Wire Current-Voltage Analyzer

The Three-Wire Current-Voltage Analyzer uses Current Hi, Current Low, and 3-wire to plot the current-voltage response of a NPN BJT.

**Table 3-5.** NPN Transistor to Prototyping Board Connections

NPN Transistor Node	Prototyping Board Connections
Collector	3-Wire
Base	Current Hi
Emitter	Current Low

## Impedance Analyzer

Connect the signal to Current Hi and Current Low when using the NI ELVIS Impedance Analyzer.

## Connecting Digital I/O Signals

The digital I/O signals are TTL compatible. Refer to Appendix A, [Specifications](#), for information about the behavior of the DI and DO signals.

If you are using Bypass Mode, refer to Appendix F, [Using Bypass Communication Mode](#), for information about using digital I/O signals.

## Connecting Counter/Timer Signals

The prototyping board provides access to the DAQ device counter/timer inputs, which are also accessible from software. These inputs are used for counting TTL signals and for edge detection. The CTR0\_SOURCE, CTR0\_GATE, CTR0\_OUT, CTR1\_GATE, and CTR1\_OUT signals are connected to the default Counter 0 and Counter 1 PFI lines on the DAQ device, refer to Table 3-2. Refer to the DAQ device documentation for details on using and configuring counter/timers.

## Connecting User-Configurable Signals

The prototyping board provides several different user-configurable connectors: four banana jacks, two BNC connectors, and a D-SUB connector. Each pin of the connector has a connection to the distribution strips of the prototyping board.

Eight LEDs are provided for general digital output. The anode of each LED is connected to the distribution strip through a 220  $\Omega$  resistor, and each cathode is connected to ground.

Refer to Table 3-1 for more information about the signal names for the user-configurable I/O connectors.

---

# Calibration

Electronic components such as ADCs are characterized by nonlinearities and drift due to time and temperature. Compensating for these inherent sources of error requires device self-calibration. To improve the accuracy of the system, you should periodically calibrate both the NI ELVIS workstation and the M Series DAQ device.

## Running the NI ELVIS Calibration Utility

---

Complete the following steps to self-calibrate the M Series DAQ device:

1. Launch MAX.
2. Expand **Devices and Interfaces**.
3. Find the M Series DAQ device in the list of devices and interfaces.
4. Right-click the appropriate M Series DAQ device.
5. Select **Self-Calibrate**.

To calibrate the NI ELVIS workstation, run the calibration utility included in the NI ELVIS software from **Start»National Instruments»NI ELVIS»Calibration Wizard**.

You can use the NI ELVIS Calibration Wizard to calibrate the Variable Power Supply and Function Generator.



**Note** This calibration is only applied when using these instruments in software mode.

---

# Specifications

This appendix lists the specifications of the NI ELVIS. These specifications are typical after a 30 minute warm-up time, at 23 °C, unless otherwise noted.



**Note** NI ELVIS includes a calibration utility so that you can recalibrate the circuitry for the variable power supplies and function generator.

## Analog Input

Refer to the *Analog Input* section of the DAQ device specifications documentation.

## Arbitrary Waveform Generator<sup>1</sup>/Analog Output

Number of output channels .....	2
Maximum frequency .....	DC to DAQ device AO update rate/10
Full-power bandwidth .....	27 kHz
Output amplitude.....	±10 V
Resolution .....	12 bits or 16 bits, DAQ device dependent
Output drive current .....	25 mA
Output impedance .....	1 Ω
Slew rate.....	1.5 V/μs

---

<sup>1</sup> The Arbitrary Waveform Generator does not work with the NI 6014, NI 6024E, or NI 6036E.

## Bode Analyzer

Amplitude accuracy .....	12 or 16 bits, DAQ device dependent
Phase accuracy .....	1 degree
Frequency range .....	5 Hz to 35 kHz

## DC Power Supplies

### +15 V Supply

Output current .....	Self-resetting circuitry, not to shut down at or below 500 mA
Output voltage .....	15 V at $\pm 5\%$ no load
Line regulation .....	0.5% max
Load regulation .....	1% typ, 5% max, 0 to full load <sup>1</sup>
Ripple and noise .....	1%

### -15 V Supply

Output current .....	Self-resetting circuitry, not to shut down at or below 500 mA <sup>2</sup>
Output voltage .....	-15 V at $\pm 5\%$ no load
Line regulation .....	0.5% max
Load regulation .....	1% typ, 5% max, 0 to full load <sup>1</sup>
Ripple and noise .....	1%

---

<sup>1</sup> Full load refers to the maximum current output of the power supply. Load regulation is linear over 0 to full load; therefore at 50% of full load, the output drops by 50% of the load regulation specification.

<sup>2</sup> Total current drawn from -15 V supply and variable power supplies cannot exceed 500 mA.

## +5 V Supply

Output current .....	Self-resetting circuitry, not to shut down at or below 2 A
Output voltage .....	+5 V at $\pm 5\%$ no load
Line regulation .....	0.50% max
Load regulation .....	22% typ, 30% max 0 to full load <sup>1</sup>
Ripple and noise .....	1%

## Digital I/O

### Resolution

Digital input channels .....	8 bits
Digital output channels .....	8 bits
Digital addressing .....	4 bits

### Digital Input

$I_I$ .....	1.0 $\mu\text{A}$ max
$V_{IH}$ .....	2.0 V min
$V_{IL}$ .....	0.8 V max

### Digital Output

$V_{OH}$ .....	3.38 V min at 6 mA 4.4 V min at 20 $\mu\text{A}$
$V_{OL}$ .....	0.86 V max at 6 mA 0.1 V max at 20 $\mu\text{A}$

---

<sup>1</sup> Full load refers to the maximum current output of the power supply. Load regulation is linear over 0 to full load; therefore at 50% of full load, the output drops by 50% of the load regulation specification.

## DMM

### Capacitance Measurement

Accuracy .....	1%
Range .....	50 pF to 500 $\mu$ F in three ranges
Test frequency .....	120 or 950 Hz, software-selectable
Max test frequency voltage.....	1 V <sub>p-p</sub> sine wave, software-selectable

### Continuity Measurement

Resistance threshold .....	15 $\Omega$ max, software-selectable
Test voltage.....	3.89 V, software-selectable

### Current Measurement

Accuracy	
AC.....	0.25% $\pm$ 3 mA <sup>1,2</sup>
DC.....	0.25% $\pm$ 3 mA <sup>2</sup>
Common-mode voltage .....	$\pm$ 20 V max
Common-mode rejection .....	70 dB min
Range .....	$\pm$ 250 mA in two ranges, max
Resolution .....	12 or 16 bits, DAQ device dependent
Shunt resistance .....	0.5 $\Omega$
Voltage burden .....	2 mV/mA

### Diode Measurement<sup>3</sup>

Voltage threshold.....	1.1 V max
------------------------	-----------

---

<sup>1</sup> 25 Hz to 10 kHz

<sup>2</sup> Proper null correction when measuring on high common-mode voltage can reduce the  $\pm$ 3 mA offset error to 200  $\mu$ A of noise.

<sup>3</sup> The Two-Wire Current Voltage Analyzer SFP is the recommended instrument for diode measurement.

## Inductance Measurement

Accuracy .....	1%
Range .....	100 $\mu$ H to 100 mH
Test frequency .....	950 Hz, software-selectable
Test frequency voltage .....	1 $V_{p-p}$ sine wave, software-selectable

## Resistance Measurement

Accuracy .....	1%
Range .....	5 $\Omega$ to 3 M $\Omega$ , in four ranges
Test frequency .....	120 Hz, software-selectable
Test frequency voltage .....	1 $V_{p-p}$ sine wave, software-selectable

## Voltage Measurement

### AC

Accuracy .....	0.3% $\pm$ 0.001% full-scale <sup>1</sup>
Range .....	$\pm$ 14 $V_{rms}$ in four ranges, max

### DC

Accuracy .....	0.3% $\pm$ 0.001% full-scale, max
Range .....	$\pm$ 20 V in four ranges, max

Input impedance ..... 1 M $\Omega$

## Dynamic Signal Analyzer

Input range .....	$\pm$ 10 V in four ranges
Input resolution .....	12 or 16 bits, DAQ device dependant

---

<sup>1</sup> 100 Hz to 10 kHz



## Function Generator

Frequency range .....	5 Hz to 250 kHz in five ranges
Software-controlled frequency resolution .....	0.8%
Frequency set point accuracy.....	3% of range, max
Frequency read back accuracy.....	±0.01%
Output amplitude .....	±2.5 V
Software amplitude resolution.....	8 bits
Offset range .....	±5 V
AM voltage .....	10 V, max
Amplitude modulation.....	Up to 100%
FM voltage.....	10 V, max
Amplitude flatness	
To 50 kHz.....	0.5 dB
To 250 kHz.....	3 dB
Frequency modulation .....	±5% of full-scale, max
Output impedance.....	50 Ω guaranteed. Refer to Appendix C, <i>Theory of Operation</i> , for more information about the output impedance configuration options.

## Impedance Analyzer

Measurement frequency range.....	5 Hz to 35 kHz
----------------------------------	----------------

## Oscilloscope

Refer to the *Analog Input* section of the DAQ device specifications documentation.

## Two-Wire Current-Voltage Analyzer

Current range.....  $\pm 10$  mA

Voltage sweep range .....  $\pm 10$  V

## Three-Wire Current-Voltage Analyzer<sup>1</sup>

Minimum base current increment ..... 15  $\mu$ A

Maximum collector current..... 10 mA

Maximum collector voltage ..... 10 V

## Variable Power Supplies

### Positive Supply

Output voltage..... 0 to 12 V

Ripple and noise..... 0.25%

Software-controlled resolution..... 7 bits

Current limiting ..... 0.5 V at 160 mA,  
5 V at 275 mA,  
12 V at 450 mA

### Negative Supply

Output voltage..... 0 to  $-12$  V

Ripple and noise..... 0.25%

Software-controlled resolution..... 7 bits

Current limiting ..... 0.5 V at 130 mA,  
5 V at 290mA,  
12 V at 450mA<sup>2</sup>

---

<sup>1</sup> This SFP instrument is intended for use only with NPN BJT transistors.

<sup>2</sup> Total current drawn from  $-15$  V and the negative variable power supply cannot exceed 500 mA.

## Physical

Dimensions ..... 31.75 × 30.48 × 12.7 cm  
(12.5 × 12.0 × 5 in.)

Weight ..... 4.08 kg (9.0 lb)

## Maximum Working Voltage

Maximum working voltage refers to the signal voltage plus the common-mode voltage.

Channel-to-earth ..... ±20 V, Measurement Category I

Channel-to-channel ..... ±20 V, Measurement Category I



**Caution** Do not use for connection to signals in Categories II, III, or IV.

## Environmental

Operating temperature ..... 0 to 40 °C

Storage temperature ..... -20 to 70 °C

Humidity ..... 10 to 90% relative humidity,  
noncondensing

Maximum altitude ..... 2,000 m

Pollution Degree (indoor use only) ..... 2

## Safety

NI-ELVIS is designed to meet the requirements of the following standards of safety for electrical equipment for measurement, control, and laboratory use:

- IEC 61010-1, EN 61010-1
- UL 61010-1
- CAN/CSA-C22.2 No. 61010-1



**Note** For UL and other safety certifications, refer to the product label, or visit [ni.com/certification](http://ni.com/certification), search by model number or product line, and click the appropriate link in the Certification column.

## Electromagnetic Compatibility

Emissions .....	EN 55011 Class A at 10 m FCC Part 15A above 1 GHz
Immunity .....	EN 61326:1997 + A2:2001, Table 1
EMC/EMI.....	CE, C-Tick, and FCC Part 15 (Class A) Compliant



**Note** For EMC compliance, operate this device with shielded cabling. In addition, all covers and filler panels must be installed.

## CE Compliance

NI-ELVIS meets the essential requirements of applicable European Directives, as amended for CE marking, as follows:

Low-Voltage Directive (safety) .....	73/23/EEC
Electromagnetic Compatibility Directive (EMC) .....	89/336/EEC



**Note** Refer to the Declaration of Conformity (DoC) for this product for any additional regulatory compliance information. To obtain the DoC for this product, visit [ni.com/certification](http://ni.com/certification), search by model number or product line, and click the appropriate link in the Certification column.

# B

## Protection Board Fuses

This appendix describes the fuses on the NI ELVIS Protection Board and provides instructions on how to remove the protection board from the NI ELVIS Benchtop Workstation, debug the protection board, and change fuses.

### Removing the Protection Board

The protection board detaches from the NI ELVIS Benchtop Workstation as shown in Figure B-1. Refer to the *Where to Start with NI ELVIS* document for more parts locator diagrams of the NI ELVIS Benchtop Workstation.

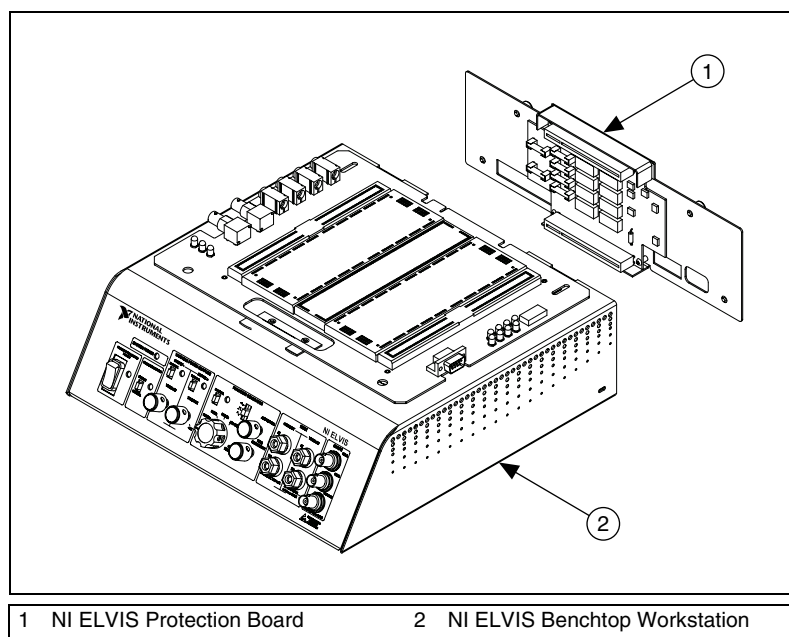

**Figure B-1.** NI ELVIS Benchtop Workstation with Protection Board Removed

Complete the following steps to remove the protection board from the benchtop workstation. Refer to Figure B-1 as needed.

1. Unplug the power cable. Refer to the *Where to Start with the NI ELVIS* document for an illustration of the switch location.
2. Unplug the 68-pin cable and the power supply cable from the benchtop workstation.
3. Disconnect the prototyping board from the benchtop workstation.
4. Unscrew the captive screws located on the back of the NI ELVIS Protection Board.
5. Gently pull on the captive screws to remove the protection board.

## Debugging the Protection Board

---

The protection board provides a level of electrical protection between the prototyping board and the motherboard of the NI ELVIS workstation. This protection consists of fuses for the high-current signals—such as the AO channels and DMM, and 100  $\Omega$  current-limited resistors for the low-current signals—such as the AI channels and digital signals. If too much current begins to flow to or from a particular signal on the prototyping board, the fuse or resistor breaks down, opening the connection electrically.

The +15 V, –15 V, and +5 V lines are protected by self-resetting circuitry. After the cause of the circuit problem is resolved, the circuit resets.

To debug the protection board, you need a DMM with an ohmmeter. Complete the following steps to debug the protection board:

1. Unplug the power cable.
2. Remove the protection board assembly from the rest of the NI ELVIS workstation. For instructions on removing the protection board, refer to the [Removing the Protection Board](#) section.
3. Check the fuses, since these signals are much more likely to have been overloaded. To check the fuse, verify that there is continuity across the fuse. If all the fuses are operational, proceed to the resistor packs.
4. Verify that the resistance across each resistor is 100  $\Omega$ ,  $\pm 5\%$ . One resistor is located between each of the following pairs of pins: 1 and 16, 2 and 15, 3 and 14, 4 and 13, 5 and 12, 6 and 11, 7 and 10, and 8 and 9. The resistor packs are socketed so that you can easily replace resistors.



**Caution** Before restoring power to the circuit, be sure the problem that caused the protection board component to fail has been resolved to keep the same fuse or resistor from failing again.

If you replace a fuse, use a 0.5 A/250 V (T 0.5 A L 250V), 5 × 20 mm, slow blow Littelfuse.



**Cautions** For continued protection against fire, replace only with fuses of the same type and rating.

The fuses on NI ELVIS are glass. Use care when removing the fuses to prevent injury from broken glass.

Figure B-2 shows the location of the different fuses and circuit protection circuitry for the NI ELVIS hardware, and the location of the resistor packs.

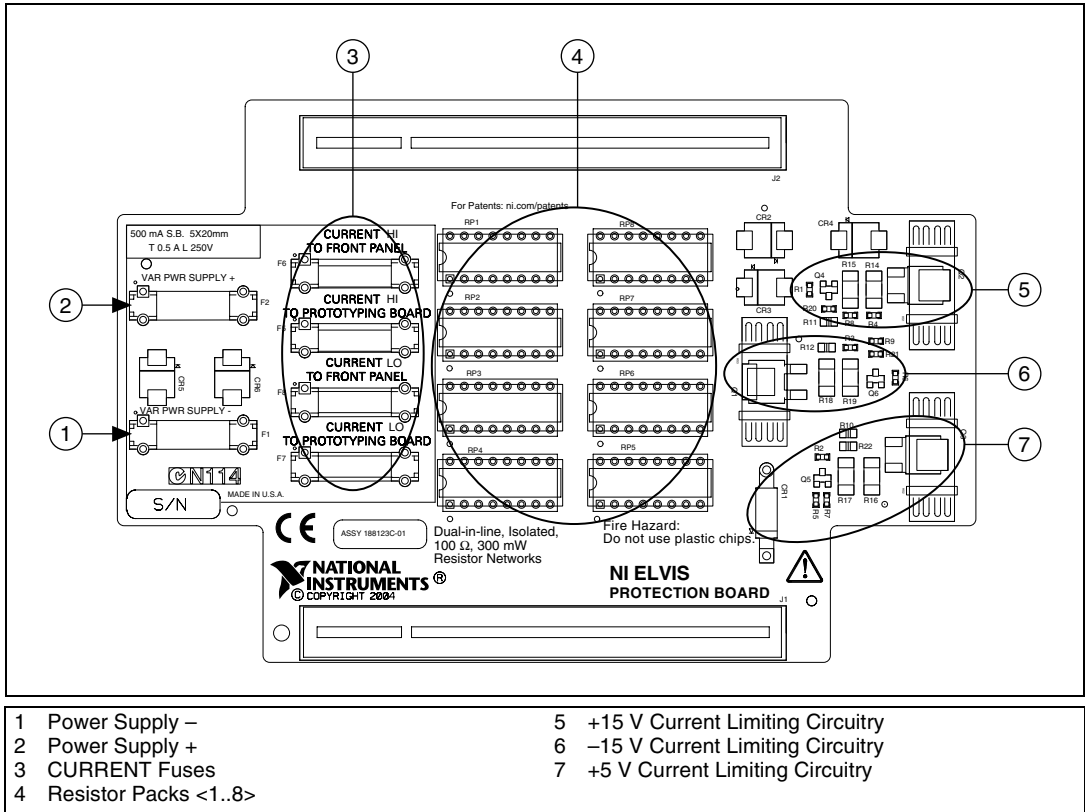

**Figure B-2.** Parts Locator Diagram for NI ELVIS Protection Board

Table B-1 shows the relationship between the resistor packs and the NI ELVIS components.

**Table B-1.** Resistor Packs and NI ELVIS Components

Resistor Pack	NI ELVIS Component
RP1	Analog input
RP2	Analog input
RP3	AM_IN, FUNC_OUT, SYNC_OUT, AI SENSE
RP4	Counter/timer I/O
RP5	Digital output
RP6	Digital input
RP7	SCANCLK, programmable function I/O
RP8	ADDRESS <0..3>

## Reinstalling the Protection Board

---

Reinstall the NI ELVIS Protection Board before resuming use of NI ELVIS. To replace the protection board, complete the following steps:

1. Reinsert the PCI connector of the protection board into the benchtop workstation rear connector.
2. Tighten the four captive screws located on the back of the protection board.
3. Plug in the 68-pin cable and the power supply.
4. Plug in the power cable.
5. Power on NI ELVIS.





---

# Theory of Operation

This appendix provides additional information about the basic operation of the NI ELVIS circuitry for the DMM, function generator, impedance analyzer, two- and three-wire current-voltage analyzers, and analog output.



**Note** To reduce measurement error, calibrate the DAQ device before each session.

---

## DMM Measurements

The DAQ device is configured for differential measurement mode for all DMM measurements. Each DMM reading is referenced to the NI ELVIS GROUND signal. The NI ELVIS software typically sets the input signal limitations, but some NI ELVIS SFP instruments allow you to manually change the limits.



**Note** NI ELVIS does not support measuring signals with large common-mode voltages. You must ground reference floating signals.

## Voltmeter

When you use the voltmeter, differential channel seven of the DAQ device (AI 7 and AI 15) is used to read the voltage signal from NI ELVIS. NI ELVIS applies a gain of 0.5 to the voltages that are applied to VOLTAGE HI and VOLTAGE LO.

## Block Diagram

Figure C-1 shows a basic block diagram of the NI ELVIS voltmeter. The paragraphs that follow the figure describe each section of the figure in more detail.

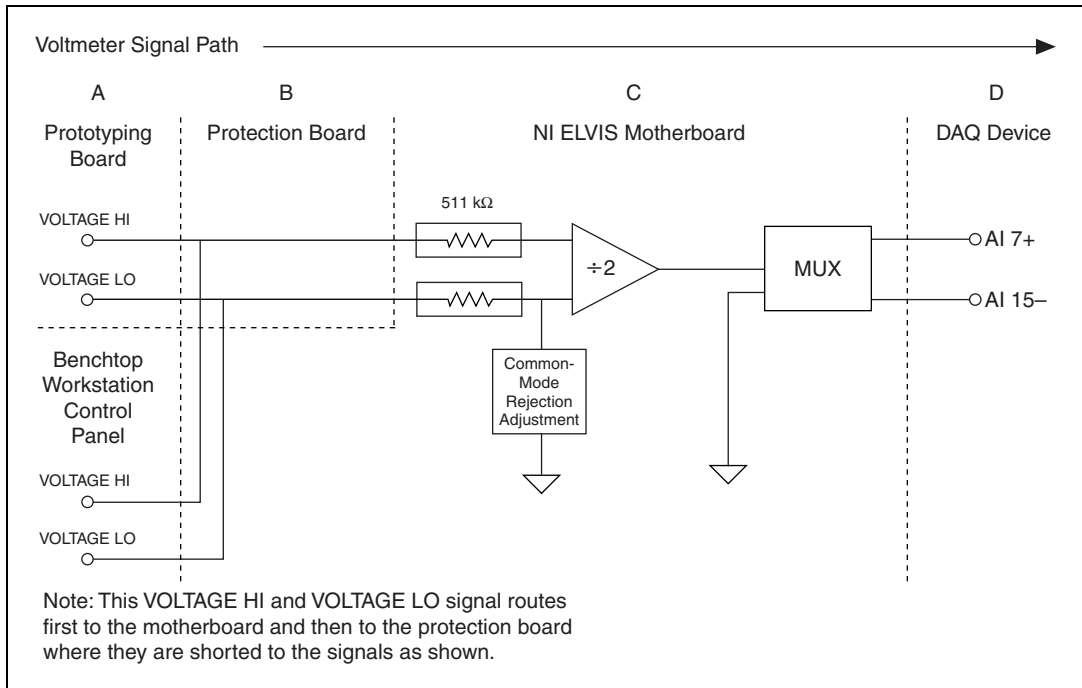

**Figure C-1.** NI ELVIS Voltmeter Block Diagram

**Prototyping Board and Benchtop Workstation Connectors**—The input to the NI ELVIS voltmeter circuit can come from the NI ELVIS Prototyping Board or from the connectors on the NI ELVIS Benchtop Workstation control panel. When the prototyping board is powered off, both connections remain active.

**Protection Board**—The inputs to the voltmeter are not externally protected on the NI ELVIS Protection Board. The two inputs are combined on the protection board and passed to the NI ELVIS motherboard.

**NI ELVIS Motherboard**—The VOLTAGE HI and VOLTAGE LO input terminals are divided with 511 k $\Omega$  input resistors. A manual adjustment is made at the factory for common-mode rejection. The adjusted common-mode rejection is typically above 80 dB.

The operational amplifier used by NI ELVIS is a fully differential JFET input with a gain of 0.5. The input slew rate is typically 11 V/ $\mu$ s. This high slew rate helps minimize AC signal distortion.

The internal NI ELVIS bus sets the differential channel seven multiplexer to read the voltmeter voltage. You cannot run the voltmeter with any other DMM functions.

**DAQ Device**—The DAQ device takes the voltage reading on differential channel seven and converts the raw voltage into the voltage reading that is displayed in the NI ELVIS software.

## Internal Calculations

The following values are stored in the NI ELVIS EEPROM:

- *Gain*—Gain error correction for NI ELVIS and the DAQ device
- *Offset*—Offset error correction for NI ELVIS and the DAQ device

These values are used when calculating voltage readings from the NI ELVIS. To calculate the voltage read on differential channel seven, use the following formula:

$$\text{Voltage Read} = \frac{\text{VOLTAGE HI} - \text{VOLTAGE LO}}{2}$$

The NI ELVIS software then performs the following calculations:

$$\text{Voltage Returned DC} = (\text{Voltage Read} - \text{Offset}) \times \text{Gain}$$

$$\text{Voltage Returned AC} = \text{Gain} \times \sqrt{(\text{VAC}^2 - \text{VDC}^2)}$$

*Voltage Returned* is displayed in the NI ELVIS software.

## Current Meter

When you use the current meter, differential channel seven of the DAQ device (AI 7 and AI 15) is used to read the current from NI ELVIS. The current read from NI ELVIS is referenced to the NI ELVIS GROUND signal. The current is measured across the CURRENT HI and CURRENT LO terminals. The current flowing across the shunt is converted to voltage by a difference amplifier.

## Block Diagram

Figure C-2 shows a basic block diagram of the NI ELVIS current meter. The paragraphs that follow the figure describe each section of the figure in more detail.

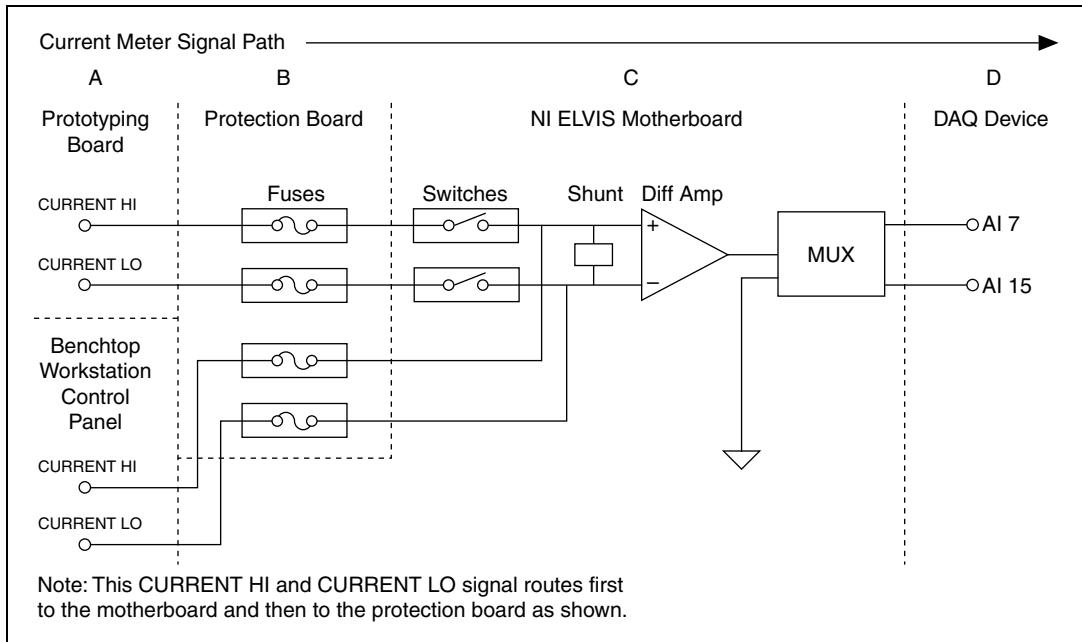

**Figure C-2.** NI ELVIS Current Meter Block Diagram

**Prototyping Board and Benchtop Workstation Connectors**—The input to the NI ELVIS current meter circuit can come from the NI ELVIS Prototyping Board or from the connectors on the NI ELVIS Benchtop Workstation control panel. When the prototyping board is powered off, the CURRENT HI and CURRENT LO terminals from the prototyping board are disconnected, and any current from the prototyping board stops flowing.

**Protection Board**—The protection board has fuses for each channel. These fuses handle overcurrent conditions.

**NI ELVIS Motherboard**—A 0.5  $\Omega$  current shunt resistor is used at the input of a difference amplifier to convert the current to a voltage.

The current meter is not adjusted for common-mode rejection. The common-mode rejection of the current meter is determined by the difference amplifier.

The output voltage is multiplexed to differential channel seven.

**DAQ Device**—The DAQ device takes the reading on differential channel seven and converts the voltage reading into the current that is displayed in the NI ELVIS software.

## Internal Calculations

The following values are stored in the NI ELVIS EEPROM:

- *Gain*—Shunt resistor value, gain error correction for NI ELVIS and the DAQ device are included
- *Offset*—System offset error correction, includes NI ELVIS and DAQ device offset

The voltage returned can represent AC or DC current. The offset variable should remove most offset caused by NI ELVIS and/or the DAQ device.

*VDC*—DC measurement of the voltage on differential channel seven

*VAC*—AC measurement of the voltage on differential channel seven

$$\text{Current AC} = \text{Gain} \times \sqrt{(\text{VAC}^2 - \text{VDC}^2)}$$

$$\text{Current DC} = (\text{VDC} - \text{Offset}) \times \text{Gain}$$

*Current AC* or *Current DC* is displayed in the NI ELVIS software.

# Function Generator

NI ELVIS includes a hardware function generator. The function generator can generate sine, triangle, and square waves. You can modulate the output amplitude and frequency manually, with software, or using a combination of both.

## Block Diagram

Figure C-3 shows a basic block diagram of the NI ELVIS function generator. The paragraphs that follow the figure describe each section of the figure in more detail.

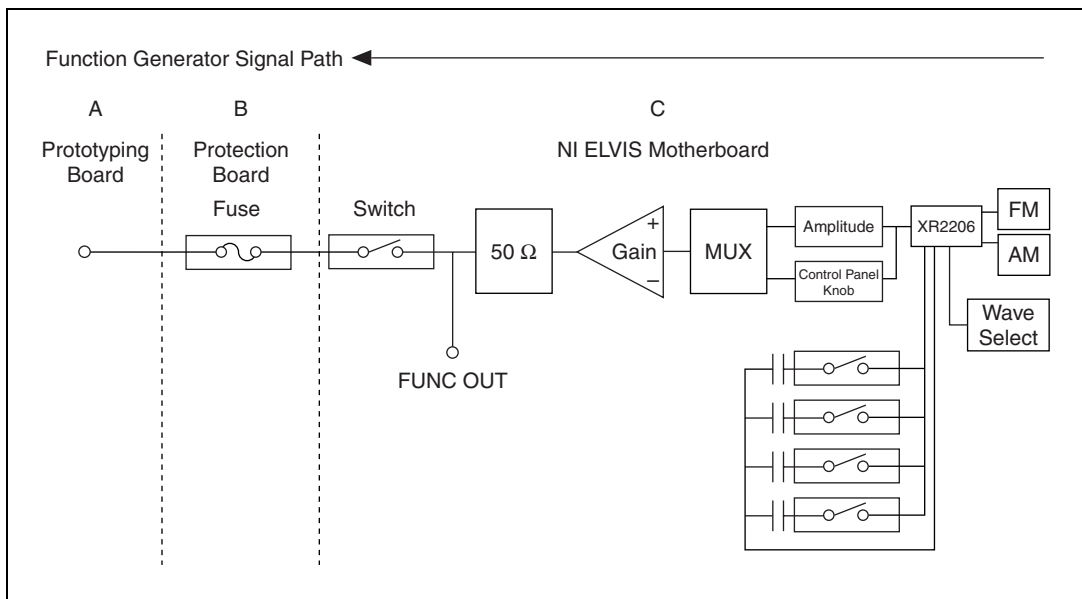

**Figure C-3.** Function Generator Block Diagram

**Prototyping Board and Benchtop Workstation Connectors**—The function generator output signal, FUNC\_OUT, is only on the prototyping board.

**Protection Board**—On the protection board, the function generator passes through a 100 Ω current-fused resistor.

**NI ELVIS Motherboard**—NI ELVIS uses a monolithic function generator integrated circuit (IC) to generate waveforms. This IC accepts frequency and amplitude modulation. You can adjust the output amplitude

of the XR 2206 with an internal 8-bit MDAC or manually with a knob on the NI ELVIS Benchtop Workstation control panel.

The coarse frequency is set by using one of four frequency selection capacitors. The fine frequency is adjusted by the adjusting the onboard 8-bit DAC.

The adjusted output signal is multiplexed into a unity gain circuit. The output of the gain circuit runs through a 50  $\Omega$  resistor. NI ELVIS uses the function generator output signal, FUNC\_OUT, after the 50  $\Omega$  resistor for other internal instruments.

You can disconnect the function generator from the NI ELVIS Prototyping Board with the prototyping board power switch.

## Impedance Analyzer

The NI ELVIS - Impedance Analyzer is an SFP instrument that can measure specific device under test (DUT) impedance characteristics. NI ELVIS determines impedance using an AC sine wave source that is produced by the NI ELVIS function generator on the CURRENT HI pin to excite the DUT. The resulting sine waves are measured on CURRENT HI and CURRENT LO. The NI ELVIS Impedance Analyzer breaks out the phase, magnitude, resistance, and reactance of the DUT.

### Block Diagram

Figure C-4 shows a basic block diagram of the NI ELVIS impedance analyzer. The diagrams and paragraphs that follow Figure C-4 describe the circuitry for the CURRENT HI and CURRENT LO signals.

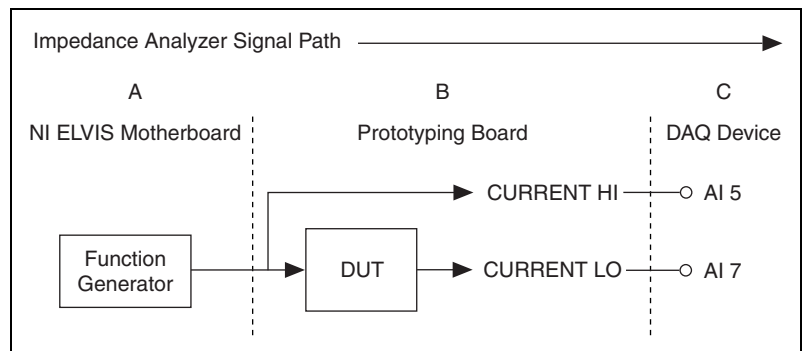

**Figure C-4.** Impedance Analyzer Block Diagram

## CURRENT HI

The hardware connection to the CURRENT HI pin is shown in Figure C-5. The paragraphs that follow the figure describe each section of the figure in more detail.

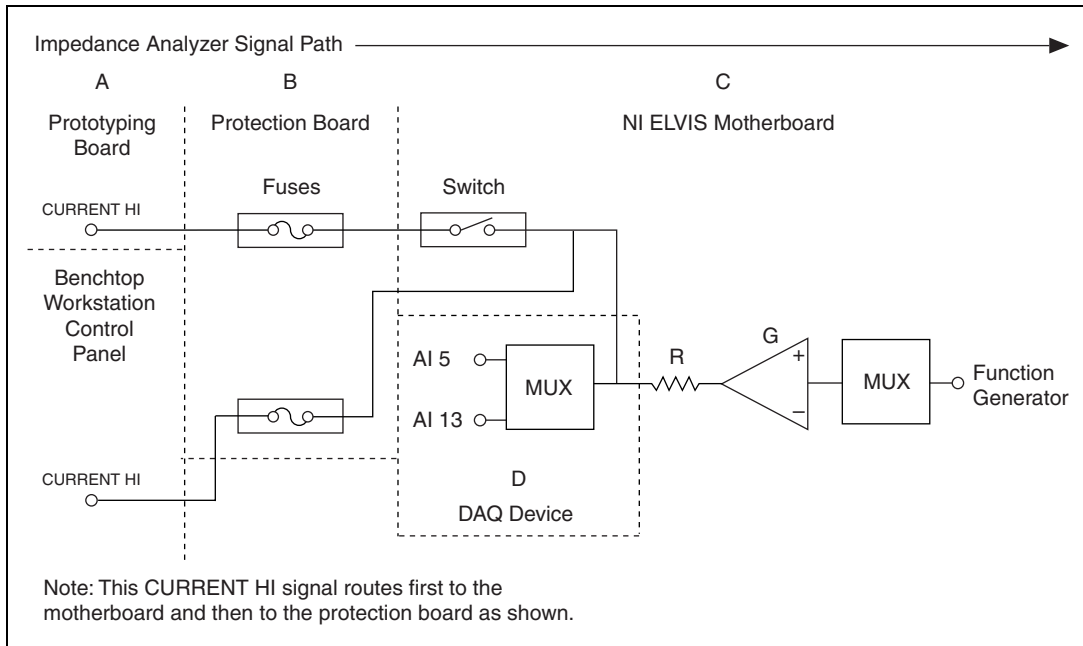

**Figure C-5.** CURRENT HI Block Diagram

**NI ELVIS Motherboard**—The output of the NI ELVIS hardware function generator is routed internally to the gain of the CURRENT HI pin.

The gain circuit (labeled *G* in Figure C-5) provides a resistive element (labeled *R* in Figure C-5) to always insure a minimum resistance.

CURRENT HI is routed to AI 5 for measurements. Because the AI 5 voltage is measured after the onboard resistor, the onboard resistor is not included in the calculations.

The output to the NI ELVIS Prototyping Board is controlled by the prototyping board power switch.

**Protection Board**—The output of the CURRENT HI is fused for overcurrent protection. Simple shorts should not blow the fuse.



**Prototyping Board and Benchtop Workstation Connectors**—When the NI ELVIS Prototyping Board is powered off, the CURRENT HI pin from the prototyping board is disconnected; however, the NI ELVIS Benchtop Workstation control panel connection is always connected.

**DAQ Device**—The DAQ device reads the reference sine wave on AI 5. The AI 5 voltage reading is the input from the NI ELVIS to the DUT.

## CURRENT LO

The hardware connection to the CURRENT LO pin is shown in Figure C-6. The paragraphs that follow the figure describe each section of the figure in more detail.

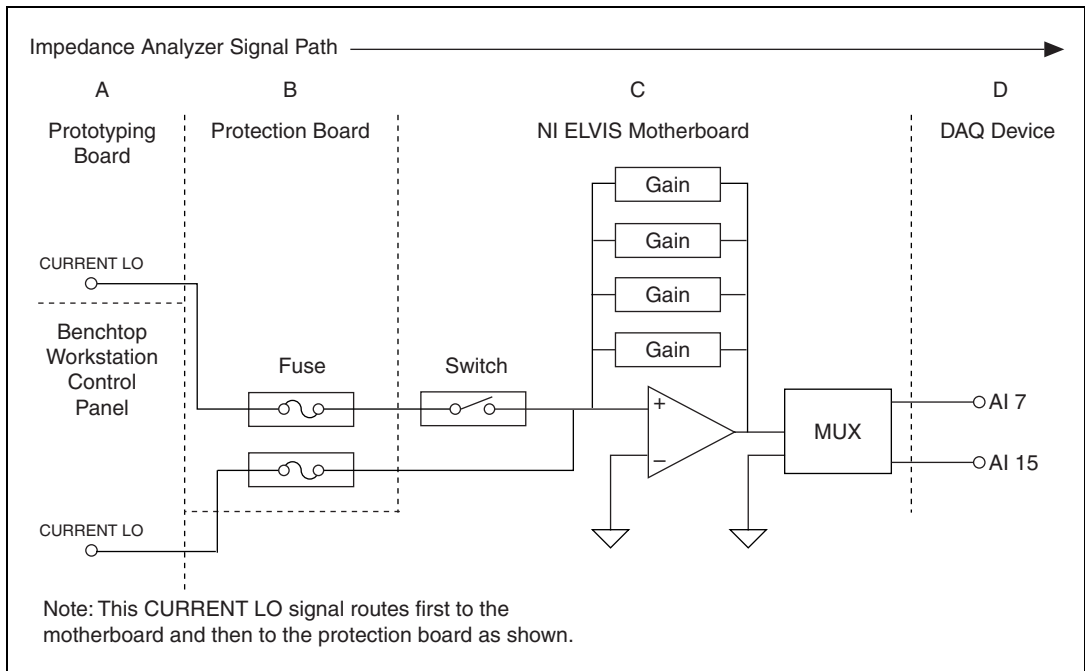

**Figure C-6.** CURRENT LO Block Diagram

**Prototyping Board and Benchtop Workstation Connectors**—When the NI ELVIS Prototyping Board is powered off, the CURRENT LO pin from the prototyping board is disconnected. The NI ELVIS Benchtop Workstation control panel connection is always connected.

**Protection Board**—The signal from the DUT passes through a fuse on the protection board. This fuse adds resistance to the measurement.

**NI ELVIS Motherboard**—When the prototyping board is powered off, the CURRENT LO pin from the prototyping board is disconnected.

You can switch the input path between impedance and current measurements by modifying the LabVIEW VIs that are included in the NI ELVIS source code. You cannot measure impedance and current at the same time.

The input voltage across the DUT has a programmable gain applied. NI ELVIS has four programmable gain ranges that you can select with the NI ELVIS - Impedance Analyzer SFP.

The input to the op-amp is protected from overvoltage and overcurrent conditions. This protection should prevent damage to the op-amp or the gain stage. The output of the op-amp is multiplexed to differential channel seven.

**DAQ Device**—The DAQ device reads the output sine wave on differential channel seven. The AI 7 reading is used as the signal (reference B) for the impedance measurements.

## Internal Calculations

The following values are stored in the NI ELVIS EEPROM:

- *Gain*—System gain error correction, gain error correction for NI ELVIS and the DAQ device
- *Inductance Offset*—System inductance offset error correction, NI ELVIS and the DAQ device
- *Capacitance Offset*—System capacitance offset error correction, NI ELVIS and the DAQ device
- *CA Slope*—Actual calibrated value of each feedback resistor (four values)

The software acquires two waveforms from differential channel seven (the signal) and AI 5 (the reference channel) and applies the following formula:

$$\text{Gain Amplitude} = \frac{\text{Referenced Amplitude}}{\text{Signal Amplitude}}$$

*Gain Amplitude* is combined with the feedback resistor used on the NI ELVIS to determine the impedance. *CA Slope* is calibrated at the factory to determine the actual impedance for the feedback resistor.

$$\text{Impedance (Z)} = \frac{\text{CA Slope}}{\text{Gain Amplitude}}$$

Z is combined with the phase to determine the resistive and reactive components of the DUT. The phase difference of the acquired sine waves is measured in reference to AI 5,

$$\text{Reactance} = Z \times \cos\left(\text{Phase} \times \frac{\pi}{180}\right)$$

$$\text{Reactance} = Z \times \sin\left(\text{Phase} \times \frac{\pi}{180}\right)$$

$$\text{Susceptance} = \frac{-1}{\text{Reactance}}$$

to determine the inductive or capacitive elements of the DUT, *Reactance* and *Susceptance*. The magnitude of the phase determines which element is present. The frequency is the frequency you set.

$$\text{Inductance} = \frac{\text{Reactance}}{2 \times \pi \times \text{Frequency}} + \text{Inductance Offset}$$

$$\text{Capacitance} = \frac{\text{Susceptance}}{2 \times \pi \times \text{Frequency}} + \text{Capacitance Offset}$$

Each inductance and capacitance reading includes the offset variable stored in the EEPROM to help eliminate offset errors.

## Resistance Meter

The resistance meter is a subset of the NI ELVIS - Impedance Analyzer, and it uses the same circuitry. To get more accurate readings, the function generator output frequency is set to 120 Hz, and the amplitude is locked at 1 V<sub>p-p</sub>. These settings allow a focused calibration that reduces resistive and capacitive offset. The resistance meter uses four ranges to measure from 5 Ω to 3 MΩ.

## Inductance Meter

The inductance meter is a subset of the NI ELVIS - Impedance Analyzer, and it uses the same circuitry. To get more accurate readings, the function generator output frequency is set to 950 Hz, and the amplitude is locked at 1 V<sub>p-p</sub>. These settings allow a focused calibration that reduces resistive and capacitive offset.

## Capacitance Meter

The capacitance meter is a subset of the NI ELVIS - Impedance Analyzer, and it uses the same circuitry. You can select electrolytic and normal capacitors. To get more accurate readings on electrolytic capacitors, the function generator output frequency is set to 120 Hz, and the amplitude is locked at 2 V<sub>p-p</sub> with a DC offset of 2.5 V. For normal capacitors, the function generator output frequency is set to 950 Hz, and the amplitude is locked at 1 V<sub>p-p</sub>. These settings allow a focused calibration that reduces resistive and capacitive offset.

## Two-Wire Current-Voltage Analyzer

The two-wire measurement is made by using the DAQ device AO 0 signal to generate a user-controlled voltage sweep. The voltage is read before the DUT on AI 5 and then across the DUT on AI 7. The NI ELVIS Impedance - Analyzer circuitry provides the feedback resistor that transforms the current flowing into the CURRENT LO pin into a voltage. The CURRENT HI pin is the output voltage source on the prototyping board and benchtop workstation control panel.

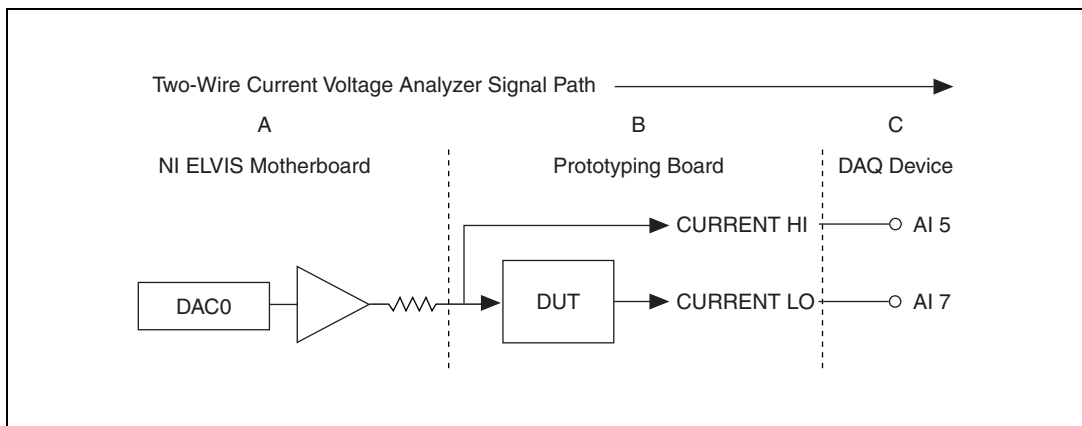

**Figure C-7.** Two-Wire Measurement Block Diagram

## Internal Calculations

The following values are stored in the NI ELVIS EEPROM:

*CA Slope*—Actual value of each feedback resistor (four values)

The voltage output on CURRENT HI pin is from the DAQ device DAC0. The CURRENT HI pin is read on AI 5 and stored as the *VOLTAGE* (V) that is displayed.

The input current is measured on the CURRENT LO pin of the prototyping board. The CURRENT LO pin is read on AI 7. The DAQ device can only read voltage, so the current is converted to voltage. The NI ELVIS - Impedance Analyzer circuitry converts the current to voltage.

The voltage read is then converted back to current using Ohm's Law:

$$V = I \times R$$

For  $R$ , use the NI ELVIS feedback resistor, *CA Slope*, and for  $V$ , use the AI 7 voltage.

$$\text{Measured Current (in Amps)} = \frac{\text{CH7 voltage}}{\text{CA Slope}}$$

*Measured Current* is converted to milliamps and displayed.

## Three-Wire Current-Voltage Analyzer

---

The three-wire measurement is made by using the DAQ device AO 0 and AO 1 to generate output voltages that you control. The voltage is read before going into the DUT on AI 5 and AI 6 and then across the DUT on AI 7. The NI ELVIS - Impedance Analyzer circuitry provides the feedback resistor that transforms the current flowing into the CURRENT LO pin into a voltage. The CURRENT HI pin is the output current source for the DUT on the prototyping board. This current is measured and converted to voltage by a 332  $\Omega$  resistor on NI ELVIS. The 3-WIRE pin is measured on AI 6 and is the source voltage that is swept.

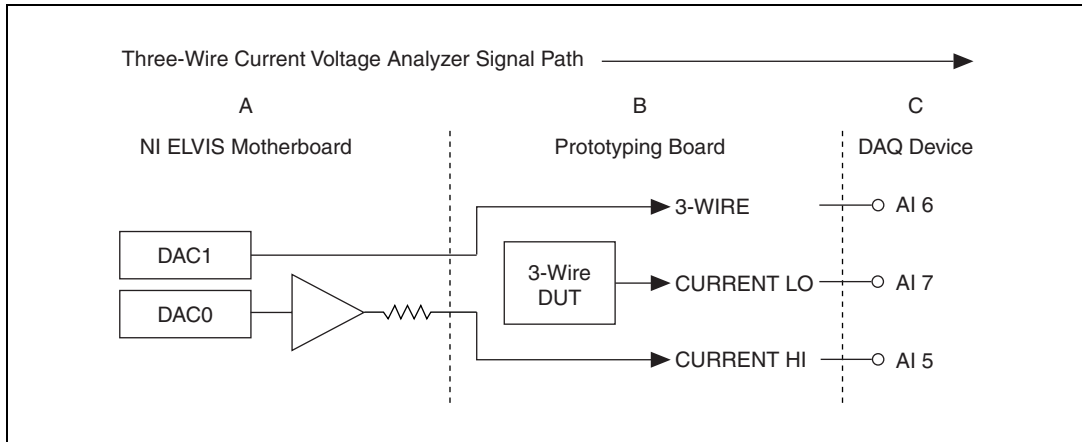

**Figure C-8.** Three-Wire Measurement Block Diagram

## Internal Calculations

The following values are stored in the NI ELVIS EEPROM:

*CA SLOPE*—Actual value of each feedback resistor (four values)

The voltage generated on the 3-WIRE pin is from the DAQ device AO 1. This voltage is read on AI 6 internal to NI ELVIS. This voltage is displayed as the Voltage ( $V_c$ ) in the Three-Wire Current-Voltage Analyzer SFP.

The base current output on the CURRENT HI pin is from the DAQ device AO 0. The CURRENT HI pin is read on AI 5 as a voltage. The DAQ device can only read voltage, so the current is converted to voltage.

The voltage read is then converted back to current by using Ohm's Law.

For  $R$ , use the NI ELVIS onboard  $332 \Omega$  resistor, and for  $V$ , use the CH5 voltage.

$$I_b \text{ (Amps)} = \frac{\text{CH5 voltage}}{332 \Omega}$$

The Base current,  $I_b$ , is not displayed on the SFP.

The input collector current is measured on the CURRENT LO pin of the prototyping board. The CURRENT LO pin is read on AI 7. The DAQ device can only read voltage, so the current is converted to voltage. The NI ELVIS Impedance - Analyzer circuitry is used to convert the current to voltage.

The voltage read is then converted back to current by using Ohm's Law.

For  $R$ , use the NI ELVIS feedback resistor,  $CA\ Slope$ , and for  $V$ , use the CH7 voltage.

$$I_c \text{ (in Amps)} = \frac{\text{CH7 voltage}}{CA\ Slope}$$

The collector current is displayed as Current  $I_c$  (A).

To determine the Beta,  $\beta$ , of the DUT, use the following equation:

$$\beta = \frac{I_c}{I_b}$$

$\beta$  is not displayed on the SFP.

## Arbitrary Waveform Generator/Analog Output

The NI ELVIS buffers the output from the DAQ device. This buffer prevents damage to the DAQ device. The NI ELVIS is protected against overvoltage and overcurrent conditions.

Figure C-9 shows a basic block diagram of the NI ELVIS AO circuitry. The paragraphs that follow the figure describe each section of the figure in more detail.

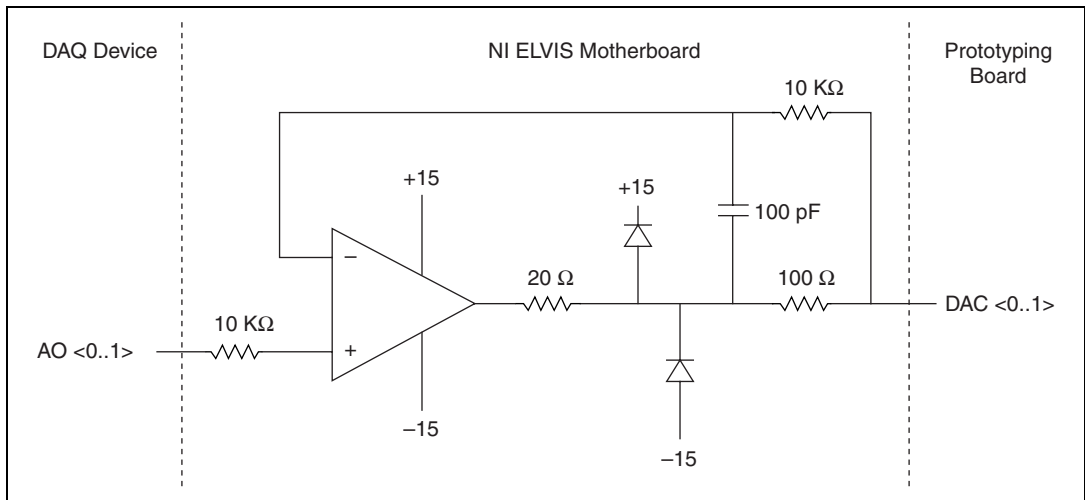

**Figure C-9.** Analog Output Block Diagram

**Prototyping Board**—You can only access the output channels of the NI ELVIS DAC <0..1> on the prototyping board. When the prototyping board is powered off, the output is disconnected.

**NI ELVIS Motherboard**—The DAQ device AO 0 and AO 1 are buffered on the NI ELVIS. This buffer allows the NI ELVIS power supply to drive DAC0 and DAC1 on the prototyping board. The DAQ device provides the voltage, but not the current. The output signal is not adjusted for offset caused by NI ELVIS.

Refer to the *Arbitrary Waveform Generator/Analog Output* section of Appendix A, *Specifications*, for further details.

**DAQ Device**—The DAQ device must have analog output capability to use the NI ELVIS analog output. In order to generate waveforms or patterns, the DAQ device must have buffered output.



---

## Resource Conflicts

Figure D-1 summarizes the resource conflicts you might encounter if you run certain NI ELVIS circuitry simultaneously. The variable power supplies and digital circuitry are not included in this figure because they do not create any resource conflicts.

To use the information in Figure D-1, find the instrument you want to use in the left column. That row lists all the functions that are resource conflicts. If the intersecting box contains an –, you can use those functions simultaneously without any conflicts.

	Function Generator – Base	Function Generator – Ultrafine	Function Generator – Modulated	ARB DAC <0..1>	Oscilloscope	Dynamic Signal Analyzer	DMM – Continuity Tester	DMM – Resistance Meter	DMM – Capacitance Meter	DMM – Inductance Meter	DMM – Voltmeter	DMM – Ammeter	DMM – Diode Tester	Impedance Analyzer	Bode Analyzer	Two-Wire Current-Voltage Analyzer	Three-Wire Current-Voltage Analyzer
Function Generator – Base	–	fg	fg	–	–	–	–	fg	fg	fg	–	–	–	fg	fg	–	–
Function Generator – Ultrafine	fg	–	fg	ao	–	–	–	fg	fg	fg	–	–	–	fg	fg	–	–
Function Generator – Modulated	fg	fg	–	ao	–	–	–	fg	fg	fg	–	–	–	fg	fg	–	–
ARB DAC <0..1>	–	ao	ao	–	–	–	ao	–	–	–	–	–	ao	–	–	ao	ao
Oscilloscope	–	–	–	–	–	ais	aid	aid	aid	aid	aid	aid	aid	aid	aid	aid	aid
Dynamic Signal Analyzer	–	–	–	–	ais	–	aid	aid	aid	aid	aid	aid	aid	aid	aid	aid	aid
DMM – Continuity Tester	–	–	–	ao	aid	aid	–	ca	ca	ca	ais	ca	ca	ca	aid	ca	ca
DMM – Resistance Meter	fg	fg	fg	–	aid	aid	ca	–	ca	ca	ais	ca	ca	ca	aid	ca	ca
DMM – Capacitance Meter	fg	fg	fg	–	aid	aid	ca	ca	–	ca	ais	ca	ca	ca	aid	ca	ca
DMM – Inductance Meter	fg	fg	fg	–	aid	aid	ca	ca	ca	–	ais	ca	ca	ca	aid	ca	ca
DMM – Voltmeter	–	–	–	–	aid	aid	ais	ais	ais	ais	–	ca	ca	ca	aid	ca	ca
DMM – Ammeter	–	–	–	–	aid	aid	ca	ca	ca	ca	ca	–	ca	ca	aid	ca	ca
DMM – Diode Tester	–	–	–	ao	aid	aid	ca	ca	ca	ca	ca	ca	–	ca	aid	ca	ca
Impedance Analyzer	fg	fg	fg	–	aid	aid	ca	ca	ca	ca	ca	ca	ca	–	aid	ca	ca
Bode Analyzer	fg	fg	fg	–	aid	aid	aid	aid	aid	aid	aid	aid	aid	aid	–	aid	aid
Two-Wire Current-Voltage Analyzer	–	–	–	ao	aid	aid	ca	ca	ca	ca	ca	ca	ca	ca	aid	–	ca
Three-Wire Current-Voltage Analyzer	–	–	–	ao	aid	aid	ca	ca	ca	ca	ca	ca	ca	ca	aid	ca	–

**Conflict Codes:**  
 aid = DAQ AI, different channels      fg = NI ELVIS function generator  
 ais = DAQ AI, same channels          ca = NI ELVIS current amplifier  
 ao = DAQ AO

**No Resource Conflicts:**  
 DAQ counter/timers  
 NI ELVIS vaiable power supplies  
 NI ELVIS digital output

Figure D-1. Possible Resource Conflicts

---

# Supported DAQ Devices

The NI ELVIS workstation supports the DAQ devices listed in this appendix.

## Supported M Series DAQ Devices

---

NI ELVIS supports the following M Series DAQ devices:

- NI 6221 (68-pin)
- NI 6225
- NI 6229
- NI 6251
- NI 6255
- NI 6259
- NI 6281
- NI 6289



**Note** If you are using a PCI M Series device, you must use NI ELVIS software version 2.0 or later. USB M Series devices require NI ELVIS 3.0 or later.

When using an M Series DAQ device with two 68-pin connectors, use connector 0 on the M Series DAQ device to make the connection to the NI ELVIS workstation.

## Supported Using E/B Series DAQ Devices

---

NI ELVIS supports the following E/B Series DAQ devices in addition to M Series DAQ devices:

- NI 6014
- NI 6024E
- NI 6036E
- NI 6040E (PCI-MIO-16E-4)

- NI 6052E
- NI 6070E (PCI-MIO-16E-1)

The Arbitrary Waveform Generator functionality of NI ELVIS is not available with the NI 6014, NI 6024E, or NI 6036E.



**Note** NI ELVIS supports all E Series devices that meet the criteria listed in the introduction to this appendix.

Use one of the following cables to connect the E/B Series DAQ device to the NI ELVIS workstation:

- SH68-68-EP
- R6868

Table E-1 describes signals on the NI ELVIS prototype board that route directly to the E/B Series DAQ device. When using the NI ELVIS with an E/B Series DAQ device, refer to Table E-1.

**Table E-1.** E/B Series DAQ Device Routing

Signal Name on Prototype Board	Direction <sup>1</sup>	E/B Series Signal Name	Description <sup>2</sup>
PFI 1	Input	PFI 1	See E/B Series Help for signal descriptions.
PFI 2	Input	PFI 2	
PFI 5	Input	PFI 5	
PFI 6	Input	PFI 6	
PFI 7	Input	PFI 7	
SCANCLK	Output	SCANCLK	
RESERVED	Output	EXT STROBE	
CTR0_SOURCE	Input	CTR 0 SRC	
CTR0_GATE	Input	CTR 0 GATE	
CTR0_OUTPUT	Output	CTR 0 OUT	
CTR1_SOURCE	Input	CTR 1 SRC	
CTR1_GATE	Input	CTR 1 GATE	
CTR1_OUTPUT	Output	CTR 1 OUT	
FREQ_OUT	Output	FREQ_OUT	
<sup>1</sup> On E/B Series DAQ devices, you can configure all of these signals as inputs or output; however, when used with the NI ELVIS workstation, these signals are fixed direction—either input or output.			
<sup>2</sup> Refer to the <i>PFI Signal Description</i> section and the E/B Series DAQ device Help for more complete descriptions of these signals.			

## PFI Signal Description

PFI—You can use these signals to supply an external source for AI, AO, DI, and DO timing signals or counter/timer inputs.

---

# Using Bypass Communication Mode

This appendix describes the function of the Communications switch on the NI ELVIS workstation front panel. In most applications, set the communications switch to *Normal*.

The following DAQ device functions are routed directly to the prototyping board:

- Analog input
- Analog output
- Counter I/O

You can access these functions directly, regardless of the position of the communications switch, by using the native NI-DAQmx functions supported by the DAQ device. Refer to *NI-DAQmx Help* for more information.

When the Variable Power Supply and Function Generator are switched to *Manual* mode, they are controlled directly by the controls on the NI ELVIS workstations and are not affected by the position of the communications switch.

## Normal Mode

---

When the communications switch on the NI ELVIS workstation is set to *Normal*, the digital I/O lines of the DAQ device are used for communicating to the NI ELVIS workstations and controlling its instruments from software. All NI ELVIS software functionality is available when the communications switch is set to *Normal*.

In *Normal* mode, the DI and DO digital ports are accessed using the NI ELVIS DIO functions.

## Bypass Mode

When the NI ELVIS workstation is set to *Bypass* mode, the eight digital I/O lines on Port 0 of the DAQ device are routed directly to DI <0..7> on the NI ELVIS prototyping board. In order to enable Bypass Mode, you must first set the communications switch on the NI ELVIS workstation to *Bypass*, and then execute the NI ELVIS – Enable Communications Bypass VI from LabVIEW. Figure F-1 shows the VI.

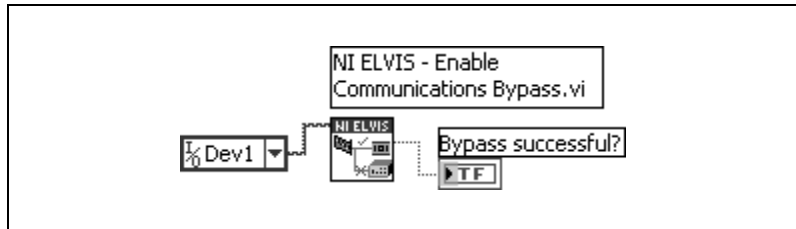

**Figure F-1.** NI ELVIS – Enable Communications Bypass VI

To access the DAQ device Digital I/O lines after enabling *Bypass* mode, you must use the NI-DAQmx Digital I/O functions. Information about using these functions is available in the *NI-DAQmx Help*.

When the communications switch is set to *Bypass* mode, communication to the NI ELVIS workstation is disabled, therefore most NI ELVIS software functionality is unavailable in *Bypass* mode.



---

# Common Questions

This appendix lists common questions related to the use of the NI ELVIS workstation.

## **Can I use the NI ELVIS SFP and the NI ELVIS API at the same time?**

No. Due to software conflicts you can only use one at a time. In order to use the LabVIEW API, you must first close the ELVIS SFP.

## **When using the current DMM function, why are measurements made at the positive side of the circuit less accurate than measurements made on the grounded side?**

The ELVIS DMM has limited common-mode rejection capabilities. For optimal accuracy, make current measurements on the grounded side of the circuit.

## **Can I use multiple NI ELVIS Workstations on one computer?**

NI ELVIS version 2.0.5 added the ability to open multiple simultaneous sessions of the NI ELVIS Instrument Launcher that you can use to control multiple NI ELVIS workstations. This assumes that each workstation is connected to a separate DAQ device. Each time you open the NI ELVIS executable a new session is instantiated, so you can have a single session open for each workstation. Once you open the NI ELVIS Instrument Launcher, click the Configure button to set both Instrument Launchers to use different DAQ devices for communication. The NI ELVIS LabVIEW API currently does not support using multiple NI ELVIS workstations on the same computer.

## **Where can I find additional NI ELVIS resources for professors or students?**

There are a number of resources for professors and students using NI ELVIS available at [ni.com/academic](http://ni.com/academic).



**Can I use the digital I/O lines on the second connector of a M Series DAQ device without interfering with NI ELVIS?**

If you use an M Series DAQ device with additional DIO functionality on the second connector with NI ELVIS, only port 0 of the DAQ device is reserved for NI ELVIS. You can use the rest of the ports without a problem.

# Glossary

---

Symbol	Prefix	Value
p	pico	$10^{-12}$
n	nano	$10^{-9}$
$\mu$	micro	$10^{-6}$
m	milli	$10^{-3}$
k	kilo	$10^3$
M	mega	$10^6$

## Symbols

%	Percent.
-	Negative of, or minus.
+	Positive of, or plus.
/	Per.
°	Degree.
$\Omega$	Ohm.
$\pm$	Plus or minus.
$\sqrt{\quad}$	Square root.

## A

A	Amperes.
AC	Alternating current.
ACH	Analog input channel signal.
ADDRESS	The DIO output signals of the address bus.

AI	Analog input.
AI GND	Analog input ground signal.
AI SENSE	Analog input sense signal.
AM	Amplitude modulation—the process in which the amplitude of a carrier wave is varied to be directly proportional to the amplitude of the modulating signal.
AM IN	Amplification modulation input signal.
amplification	A type of signal conditioning that improves accuracy in the resulting digitized signal and reduces noise.
amplitude	The voltage amplitude of a signal. When speaking of the amplitude of a signal, it is usually assumed to be the RMS value for an AC signal. However, amplitude can also refer to the instantaneous amplitude, or the peak, peak-to-peak, or average amplitude, if so specified.
AO	Analog output.
ARB	Arbitrary waveform generator.

## **B**

block diagram	Pictorial description or representation of a program or algorithm. The block diagram, consists of executable icons called nodes and wires that carry data between the nodes. The block diagram is the source code for the VI. The block diagram resides in the block diagram window of the VI.
BNC	A type of coaxial signal connector.
bode plot	The plot of the gain and phase of a system as a function of frequency.
bus	The group of conductors that interconnect individual circuitry in a computer. Typically, a bus is the expansion vehicle to which I/O or other devices are connected. An example of a PC bus is the PCI bus.

**C**

C	Celsius.
capacitance	The ability to hold an electrical charge.
CH	Channel.
channel	Pin or wire lead to which you apply or from which you read the analog or digital signal. Analog signals can be single-ended or differential. For digital signals, you group channels to form ports. Ports usually consist of either four or eight digital channels.
counter/timer	A circuit that counts external pulses or clock pulses (timing).
CTR0_GATE	Counter 0 gate signal.
CTR0_OUT	Counter 0 output signal.
CTR0_SOURCE	Counter 0 source signal.
CTR1_GATE	Counter 1 gate signal.
CTR1_OUT	Counter 1 output signal.
CURRENT	Input signals for current-related measurements for the DMM.

**D**

D/A	Digital-to-analog.
DAC	D/A converter.
DAQ	Data acquisition.
dB	Decibel—the unit for expressing a logarithmic measure of the ratio of two signal levels: $dB = 20 \log_{10} V_1/V_2$ , for signals in volts.
DC	Direct current.
default setting	A default parameter value recorded in the driver. In many cases, the default input of a control is a certain value (often 0) that means <i>use the current default setting</i> .

DI	Digital I/O input signals sent to the DI bus.
differential input	An analog input consisting of two terminals, both of which are isolated from computer ground, whose difference is measured.
digital trigger	A TTL level signal having two discrete levels—a high level and a low level.
DIO	Digital I/O.
diode	A specialized electronic component with two electrodes called the <i>anode</i> and the <i>cathode</i> .
DMM	Digital multimeter.
DO	Digital I/O output signals from the DO bus.
DOC	Canadian Department of Communications.
DSA	Dynamic signal analyzer.
DUT	Device under test.

## E

ECG	Electrocardiogram.
EEPROM	Electrically erasable programmable read-only memory—ROM that can be erased with an electrical signal and reprogrammed.
ELVIS	Educational Laboratory Virtual Instrumentation Suite.
EMC	Electromechanical compliance.
EMI	Electromagnetic interference.
EXTSTROBE	External strobe signal.

## F

FCC	Federal Communications Commission.
FGEN	Function generator.

floating signal sources	Signal sources with voltage signals that are not connected to an absolute reference or system ground. Also called nonreferenced signal sources. Some common example of floating signal sources are batteries, transformers, or thermocouples.
FM_IN	Frequency modulation input signal.
FREQ_OUT	Frequency output signal.
frequency	The basic unit of rate, measured in events or oscillations per second using a frequency counter or spectrum analyzer. Frequency is the reciprocal of the period of a signal.
front panel	The user interface of a LabVIEW virtual instrument.
FUNC_OUT	Output signal for the function generator.
<b>G</b>	
gain	The factor by which a signal is amplified, sometimes expressed in decibels.
GPCTR0_GATE	General-purpose counter timer 0 gate signal, available from a DAQ device.
GPCTR0_OUT	General-purpose counter timer 0 output signal, available from a DAQ device.
GPCTR0_SOURCE	General-purpose counter timer 0 clock source signal, available from a DAQ device.
GPCTR1_GATE	General-purpose counter timer 1 gate signal, available from a DAQ device.
GPCTR1_OUT	General-purpose counter timer 1 output signal, available from a DAQ device.
GPCTR1_SOURCE	General-purpose counter timer 1 clock source signal, available from a DAQ device.
GROUND	Prototyping board ground signal.

## H

hardware triggering      A form of triggering where you set the start time of an acquisition and gather data at a known position in time relative to a trigger signal.

Hz      Hertz—the number of scans read or updates written per second.

## I

I/O      Input/output—the transfer of data to/from a computer system involving communications channels, operator interface devices, and/or data acquisition and control interfaces.

in.      Inch or inches.

impedance      The electrical characteristic of a circuit expressed in ohms and/or capacitance/inductance.

inductance      The characteristic of a coil that generates a voltage due to changes in the current. An inductor creates a voltage that is the derivative of the current, while a capacitor creates a voltage that is the integral of the current.

## J

JFET      Junction Field Effect Transistor. A three-terminal semiconductor device constructed with a PN junction at its input and a conducting channel as the output section. The PN junction of the input section is reverse biased to provide an extremely high input resistance.

## L

LabVIEW      A graphical programming language.

LATCH      DIO output signal that pulses when data is ready on the write bus.

LED      Light-emitting diode.

**N**

NI-DAQ	National Instruments driver software for DAQ hardware.
NI-DAQmx	The latest NI-DAQ driver with new VIs, functions, and development tools for controlling measurement devices.
NPN transistor	A two-junction (bipolar) semiconductor transistor with an N-type (negative ion) collector and emitter and a P-type (positive ion) base. An NPN transistor is created by adding a thin layer of P-type semiconductor material between two regions of N-type material.
NRSE	Nonreferenced single ended mode—all measurements are made with respect to a common (NRSE) measurement system reference, but the voltage at this reference can vary with respect to the measurement system ground.

**O**

op-amp	Operational amplifier—pre-built amplifier modules that are general enough to be used almost anywhere an amplifier is needed.
--------	--

**P**

PCB	Printed circuit board.
PCI	Peripheral Component Interconnect—a high-performance expansion bus architecture originally developed by Intel to replace ISA and EISA. It is achieving widespread acceptance as a standard for PCs and workstations; it offers a theoretical maximum transfer rate of 132 Mbytes/s.
peak-to-peak	A measure of signal amplitude; the difference between the highest and lowest excursions of the signal.
PFI	Programmable function input.
PN	The simplest semiconductor structure. It consists of a positive or P-region (containing positive ions) in junction with a negative or N-region (containing negative electrons).



## R

RD_ENABLE	Read enable signal—DIO output signal that indicates when data is being read from the read bus.
referenced signal sources	Signal sources with voltage signals that are referenced to a system ground, such as the earth or a building ground. Also called grounded signal sources.
resistance	The resistance to the flow of electric current. One ohm ( $\Omega$ ) is the resistance through which one volt of electric force causes one ampere to flow.
rms	Root mean square.

## S

s	Seconds.
S	Samples.
S/s	Samples per second—used to express the rate at which a DAQ device samples an analog signal.
SCANCLK	Scan clock signal.
Scope	Abbreviation for oscilloscope.
SFP	Soft front panel
SYNC_OUT	TTL signal of the same frequency of the function generator.

## T

TIO	Timing I/O.
TRIG	Trigger signal.
trigger	Any event that causes or starts some form of data capture.
TRIGGER	Trigger input signal for the oscilloscope.
TTL	Transistor-to-transistor logic.

**V**

V Volt or volts.

VI Virtual instrument—a combination of hardware and/or software elements, typically used with a PC, that has the functionality of a classic stand-alone instrument.

VOLTAGE Input signals for the DMM voltmeter.

$V_{p-p}$  Peak-to-peak voltage.

**W**

waveform Multiple voltage readings taken at a specific sampling rate.

WR\_ENABLE DIO output signal that indicates data is being written to the write bus.

# Index

---

## Symbols

+5 V

- +5 V power supply
  - prototyping board power, 3-7
  - specifications, A-3

+5V signal

- See also* DC power supplies
- connecting analog output signals, 3-15
- signal description (table), 3-9

fuse (figure), B-3

±15 V

- 15 V signal
  - See also* DC power supplies
  - signal description (table), 3-9

+15 V signal

- See also* DC power supplies
- connecting analog output signals, 3-15
- signal description (table), 3-9

±15 V power supply

- prototyping board power, 3-7
- specifications, A-2

-15 V signal

- connecting analog output signals, 3-15

fuses (figure), B-3

## Numerics

3-WIRE signal

- See also* DMM
- connecting analog input signals, 3-14
- fuse (figure), B-3
- signal description (table), 3-8
- three-wire current-voltage analyzer theory
  - of operation, C-13

## A

academic use of NI ELVIS, 2-10, 2-11

ACH<0..5>- signals

- analog input signal mapping (table), 3-12
- signal description (table), 3-8

ACH<0..5>+ signals

- analog input signal mapping (table), 3-12
- signal description (table), 3-8

ADDRESS <0..3> signals

- See also* digital I/O
- resistor pack, B-4
- signal description (table), 3-10

AI GND signal

- analog input signal mapping (table), 3-12
- connecting analog input signals, 3-12
- signal description (table), 3-8

AI SENSE signal

- analog input signal mapping (table), 3-12
- connecting analog input signals, 3-12
- resistor pack, B-4
- signal description (table), 3-8

AM\_IN signal

- See also* function generator
- connecting analog output signals, 3-15
- resistor pack, B-4
- signal description (table), 3-9

analog input

- connecting signals, 3-12
- resistor packs, B-4
- resource conflicts, 3-13
- signal mapping (table), 3-12

- software instruments
  - bode analyzer SFP, 2-5
  - DMM SFP, 2-5
  - DSA SFP, 2-6
  - impedance analyzer SFP, 2-6
  - scope SFP, 2-6
  - three-wire current-voltage analyzer SFP, 2-7
  - two-wire current voltage analyzer SFP, 2-7
- analog output
  - connecting signals, 3-14
  - hardware instruments
    - function generator
      - controls, 3-3
      - overview, 2-2
    - variable power supplies
      - controls, 3-3
      - overview, 2-2
  - software instruments
    - ARB SFP, 2-4
    - FGEN SFP, 2-6
    - variable power supplies, 2-7
  - theory of operation, C-15
- API, overview, 2-8
- ARB
  - resource conflicts (table), D-2
  - SFP overview, 2-4
  - theory of operation, C-15

## B

- BANANA <A..D> signals
  - connecting user configurable I/O signals, 3-16
  - connector locations (figure), 3-7
  - signal description (table), 3-9

- benchtop workstation
  - controls and indicators, 3-2
  - overview, 2-2
  - parts locator diagram, 3-2
  - removing protection board, B-1
  - theory of operation, C-1

- BNC <1..2>- signals
  - connecting user configurable I/O signals, 3-16
  - signal description (table), 3-9

- BNC <1..2>+ signals
  - connecting user configurable I/O signals, 3-16
  - signal description (table), 3-9

- bode analyzer
  - resource conflicts (table), D-2
  - SFP overview, 2-5
  - specifications, A-2

- bypass mode
  - communications switch
    - location (figure), 3-2
    - overview, 3-2

## C

- calibration utility, 2-9
- CH <A..B>- signals
  - See also* oscilloscope
  - signal description (table), 3-8
- CH <A..B>+ signals
  - See also* oscilloscope
  - connecting analog input signals, 3-14
  - signal description (table), 3-8
- communications switch
  - location (figure), 3-2
  - overview, 3-2
- configuring NI ELVIS, 2-4

conflicts, resources (table), D-1

connecting signals on the prototyping board

- analog input
  - DMM, 3-14
  - generic analog input, 3-12
  - grounding, 3-12
  - oscilloscope, 3-14
  - resource conflicts
    - overview, 3-13
    - table, D-2
- analog output
  - DC power supplies, 3-15
  - function generator, 3-15
  - generic analog output, 3-14
  - variable power supplies, 3-15
- counter/timer signals, 3-16
- digital I/O, 3-16
- user-configurable signals, 3-16

connectors. *See* I/O connectors

conventions used in the manual, *iv*

counter/timers

- connecting signals, 3-16
- resistor pack, B-4
- resource conflicts (table), D-2

CURRENT HI signal

*See also* DMM

- connecting analog input signals, 3-14
- fuses (figure), B-3
- signal description (table), 3-8
- theory of operation
  - DMM, C-3
  - impedance analyzer, C-8
  - three-wire current-voltage analyzer, C-13
  - two-wire current-voltage analyzer, C-12

CURRENT LO signal

*See also* DMM

- connecting analog input signals, 3-14
- fuses (figure), B-3
- impedance analyzer theory of operation (figure), C-9
- signal description (table), 3-8
- theory of operation
  - DMM, C-3
  - three-wire current-voltage analyzer, C-13
  - two-wire current-voltage analyzer, C-12

## D

DAC<0..1> signals

*See also* analog output

- connecting analog output signals, 3-14
- fuses (figure), B-3
- internally using (caution), 3-14
- signal description (table), 3-8
- theory of operation
  - three-wire current-voltage analyzer, C-13
  - two-wire current-voltage analyzer, C-12

DAQ hardware

- definition, 1-2
- NI ELVIS components (figure), 2-1, 2-2
- overview, 1-3
- resource conflicts (table), D-2
- theory of operation, C-1

- DC power supplies
    - prototyping board power, 3-7
    - signal descriptions (table), 3-9
    - specifications
      - +5 V power supply, A-3
      - ±15 V supply, A-2
  - debugging the protection board, B-2
  - DI <0..7> signals
    - See also* digital I/O
    - connecting digital I/O signals, 3-16
    - signal description (table), 3-10
  - digital bus reader SFP, 2-5
  - digital bus writer SFP, 2-5
  - digital I/O
    - connecting signals, 3-16
    - resistor packs, B-4
    - resource conflicts, D-1
    - signal descriptions (table), 3-9, 3-10
    - software instruments
      - digital bus reader, 2-5
      - digital bus writer SFP, 2-5
  - digital multimeter. *See* DMM
  - DMM
    - connecting signals, 3-14
    - connectors
      - description, 3-4
      - location (figure), 3-2
    - internally using the DACs (caution), 3-14
    - overview, 2-5
    - resource conflicts (table), D-2
    - signal descriptions (table), 3-8
    - specifications
      - current measurement, A-4
      - voltage measurement, A-5
    - theory of operation, C-1
  - DO <0..7> signals
    - See also* digital I/O
    - connecting digital I/O signals, 3-16
    - signal description (table), 3-9
  - documentation
    - conventions used in the manual, *iv*
    - related documentation, 1-5
  - DSA
    - resource conflicts (table), D-2
    - SFP overview, 2-6
  - DSUB PIN signals, signal description (table), 3-10
  - DSUB SHIELD signal, signal description (table), 3-10
  - dynamic signal analyzer. *See* DSA
- E**
- electromagnetic compatibility
    - specifications, A-9
  - ELVIS. *See* NI ELVIS
- F**
- FGEN. *See* function generator
  - FM\_IN signal
    - See also* function generator
    - connecting analog output signals, 3-15
    - signal description (table), 3-9
  - FUNC\_OUT signal
    - See also* function generator
    - connecting analog output signals, 3-15
    - resistor pack, B-4
    - signal description (table), 3-9

function generator

- calibration utility, 2-9
- connecting signals, 3-15
- hardware
  - controls description, 3-3
  - controls location (figure), 3-2
- overview, 2-6
- resource conflicts (table), D-2
- signal descriptions (table), 3-9
- specifications, A-6
- theory of operation, C-6

fuses

- debugging the protection board, B-2
- location (figure), B-3

**G**

GLB\_RESET signal

- See also* digital I/O
- signal description (table), 3-9

GROUND signal

- See also* DC power supplies; variable power supplies
- connecting analog output signals, 3-15
- signal description (table), 3-9

**H**

hardware

- connecting signals, 3-11
- DAQ
  - definition, 1-2
  - overview, 1-3
- fuses, B-1, B-3
- installation documentation, 1-1

NI ELVIS components

- benchtop workstation, 3-2
- DAQ device, 3-1
- overview (figure), 2-1, 2-2
- protection board, 3-6
- prototyping board, 3-6
- resource conflicts (table), D-2
- specifications, A-1
- theory of operation, C-1

**I**

I/O connectors

- I/O connector descriptions, 3-16
- location (figure), 3-7
- signal descriptions (table), 3-8

impedance analyzer

- resource conflicts (table), D-2
- SFP overview, 2-6
- theory of operation, C-7

installation documentation location, 1-1

instrument launcher, 2-4

instrumentation, virtual, 1-1

**L**

LabVIEW

- NI ELVIS software instruments, 2-3
- overview, 1-3
- virtual instrumentation, 1-1

LATCH signal

- See also* digital I/O
- signal description (table), 3-9

launcher, instrument, 2-4

LED <0..7> signals

- connecting user configurable I/O signals, 3-17
- signal description (table), 3-10

**N**

## NI ELVIS

- components (figure), 2-1, 2-2
- configuring, 2-4
- hardware overview, 2-2
- instrument launcher, 2-4
- LabVIEW API, 2-8
- overview, 1-4
  - benchtop workstation, 2-2
  - DAQ hardware, 1-3
  - LabVIEW, 1-3
  - prototyping board, 2-3
- parts locator diagram, 2-1, 2-2
- software overview, 2-3
- theory of operation, C-1
- using in academic disciplines, 2-10, 2-11

**O**

## oscilloscope

- connectors (figure), 3-2
- connectors on benchtop workstation, 3-4
- overview, 2-6
- resource conflicts
  - overview, 3-13
  - table, D-2
- signal descriptions (table), 3-8
- specifications, A-6

**P**

## power supply

- DC. *See* DC power supply
- prototyping board, 3-7
- variable. *See* variable power supplies

## programmable function I/O

- resistor pack, B-4

## protection board

- debugging, B-2
- overview, 3-6
- reinstalling, B-4
- removing the protection board, B-1
- theory of operation, C-1

## prototyping board

- connecting signals
  - analog input
    - DMM, 3-14
    - generic analog input, 3-12
    - grounding, 3-12
    - oscilloscope, 3-14
    - resource conflicts
      - overview, 3-13
      - table, D-2
  - analog output
    - DC power supplies, 3-15
    - function generator, 3-15
    - generic analog output, 3-14
    - variable power supplies, 3-15
  - counter/timer signals, 3-16
  - digital I/O, 3-16
- overview, 2-3, 3-6
- parts locator diagram, 3-7
- power
  - supply, 3-7
  - switch (figure), 3-2
- signal descriptions (table), 3-8
- theory of operation, C-1



**R**

RD\_ENABLE signal  
*See also* digital I/O  
 signal description (table), 3-9  
 related documentation, 1-5  
 removing protection board, B-1  
 resistor packs  
 location (figure), B-3  
 NI ELVIS components (table), B-4  
 resource conflicts (table), D-1

**S**

safety  
 specifications, A-9  
 SCANCLK signal  
 resistor pack, B-4  
 Scope. *See* oscilloscope  
 SFP instruments  
 ARB, 2-4  
 bode analyzer, 2-5  
 digital bus reader SFP, 2-5  
 digital bus writer, 2-5  
 DMM, 2-5  
 DSA, 2-6  
 FGGEN, 2-6  
 impedance analyzer, 2-6  
 instrument launcher, 2-4  
 overview, 2-3  
 resource conflicts (table), D-2  
 Scope, 2-6  
 three-wire current-voltage analyzer, 2-7  
 two-wire current voltage analyzer, 2-7  
 variable power supplies, 2-7  
 signal descriptions (table), 3-8

## specifications

analog input, A-1  
 bode analyzer, A-2  
 DC power supplies  
 +5 V supply, A-3  
 ±15 V supply, A-2  
 DMM  
 current measurement, A-4  
 voltage measurement, A-5  
 electromagnetic compatibility, A-9  
 function generator, A-6  
 oscilloscope, A-6  
 safety, A-9  
 variable power supplies  
 negative supply, A-7  
 positive supply, A-7  
 SUPPLY– signal  
*See also* variable power supplies  
 connecting analog output signals, 3-15  
 signal description (table), 3-9  
 SUPPLY+ signal  
*See also* variable power supplies  
 signal description (table), 3-9  
 SYNC\_OUT signal  
*See also* function generator  
 connecting analog output signals, 3-15  
 resistor pack, B-4  
 signal description (table), 3-9  
 system power LED (figure), 3-2

## T

- three-wire current-voltage analyzer
  - resource conflicts (table), D-2
  - SFP overview, 2-7
  - theory of operation, C-13
- TRIGGER signal
  - See also* oscilloscope
  - signal description (table), 3-8
- two-wire current-voltage analyzer
  - resource conflicts (table), D-2
  - SFP overview, 2-7
  - theory of operation, C-12

## U

- user-configurable I/O
  - BANANA signals, 3-9
  - BNC <1..2>- signals, 3-9
  - BNC <1..2>+ signals, 3-9
  - connecting signals, 3-16
  - DSUB pin <0..9> signals, 3-10
  - DSUB shield, 3-10
  - LED <0..7> signals, 3-10

## V

- variable power supplies
  - calibration utility, 2-9
  - fuses (figure), B-3
  - hardware controls
    - description, 3-3
    - figure, 3-2
  - overview, 2-7
  - resource conflicts, D-1
  - signal descriptions (table), 3-9
  - specifications
    - negative supply, A-7
    - positive supply, A-7

- virtual instrumentation, 1-1
- VOLTAGE HI signal
  - See also* DMM
  - connecting analog input signals, 3-14
  - DMM theory of operations, C-1
  - signal description (table), 3-8
- VOLTAGE LO signal
  - See also* DMM
  - connecting analog input signals, 3-14
  - DMM theory of operations, C-1
  - signal description (table), 3-8

## W

- WR\_ENABLE signal
  - See also* digital I/O
  - signal description (table), 3-9