

**Instruction Sheet
for the PASCO
Model CI-6746**

ECONOMY FORCE SENSOR

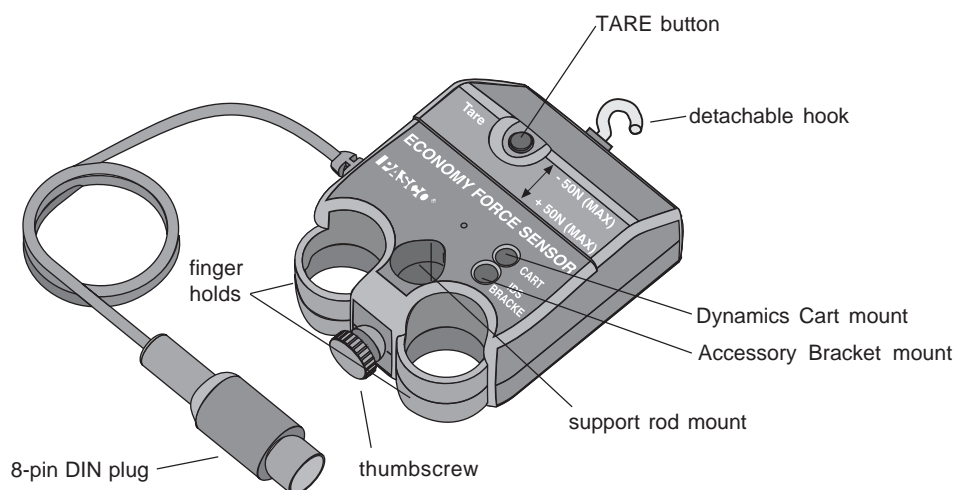

Introduction

The PASCO CI-6746 Economy Force Sensor is designed to be used with a PASCO *ScienceWorkshop* Computer Interface. This version of the force sensor has an output between -8 volts and +8 volts and a range between -50 newtons and +50 newtons. In other words, it produces -8 volts for -50 newtons, 0 volts for “zero” force, and +8 volts for +50 newtons. (A push is considered to be positive, and a pull is considered to be negative.) The sensor has strain gauges mounted on a specially designed “S-bend beam”. The beam has built-in over-limit protection so it will not be damaged if a force greater than 50 newtons is applied.

The Force Sensor consists of the housing for the beam and electronics, a cable with a 8 pin DIN plug for connecting to the computer interface, and a detachable hook. The housing has a thumbscrew (for mounting on a support rod up to 1/2” diameter) on the end opposite to the mount for the detachable hook. The housing also has two finger holds.

The bottom of the housing has an indentation that fits on the end of the accessory tray of a PASCO Dynamics Cart. The top of the housing has a mount (*Cart*) for attaching the sensor to a Dynamics Cart, a mount (*IDS Bracket*) for the Accessory Bracket with Bumpers (CI-6545) for attaching the sensor to a Dynamics Track, and a tare button for zeroing the sensor.

Equipment

INCLUDED

- Economy Force Sensor (CI-6746)
- detachable hook
- accessory mounting thumbscrew

ADDITIONAL REQUIRED

- *ScienceWorkshop* Computer Interface
- Computer

ADDITIONAL RECOMMENDED

- Introductory Dynamics System (carts, track, track accessories), such as PASCO Model ME-9429A.
- Force Sensor Bracket and Collision Bumpers (CI-6545)

Operation

Connecting and Zeroing the Sensor

1. Connect the 8-pin DIN plug to an analog channel on the computer interface.

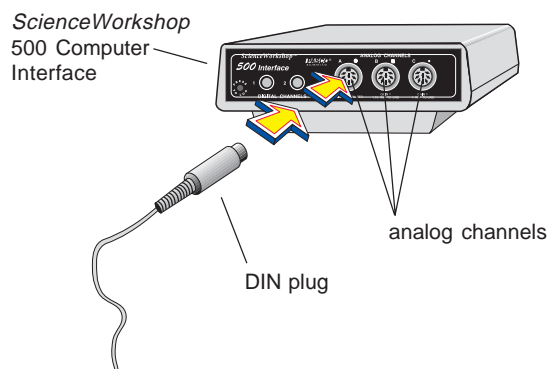

2. To “zero” the sensor, press and then release the tare button. When the tare button is pressed, the voltage from the sensor will be set to approximately zero volts.

Note: You can also zero the sensor while a force is applied to the sensor. For example, if you want to measure the *change* in force during an experiment, set up the experimental equipment as needed, and tare the sensor at the beginning of the experiment before taking data. The sensor can maintain its “zeroed” condition for more than thirty minutes.

Mounting the Sensor on a PASCO Dynamics Cart

The Economy Force Sensor has a built-in mount that aligns with the threaded holes in the accessory tray of a PASCO Dynamics Cart (such as the ME-9430 Plunger Cart or ME-9454 Collision Cart). A thumbscrew is provided to secure the Force Sensor to the cart.

To mount the sensor:

1. Position the Economy Force Sensor on the tray of the Dynamics Cart so the indentation on the bottom of the Force Sensor is seated over the end of the cart tray, and the mount for the cart is directly over the threaded hole in the accessory tray of the cart.
2. Insert the accessory mounting thumbscrew into the cart mount hole and screw it into the threaded hole in the accessory tray of the Dynamics Cart.

Mounting on a Support Rod

The Economy Force Sensor has a hole and thumbscrew at one end that allows you to mount the sensor on a support rod from 3/8” to 1/2” diameter.

Mounting on the Accessory Bracket

To fasten the Economy Force Sensor to a Dynamics Track, use the Accessory Bracket (CI-6545):

1. Place the Force Sensor on the Accessory Bracket so the IDS mount aligns with the hole near the front of the bracket.
2. Insert the accessory mounting thumbscrew into the IDS mount hole on the Economy Force Sensor, and turn it clockwise until it is tight. Mount the Accessory Bracket on the T-slot on the side of the IDS Track. (See the Accessory Bracket instruction sheet for more information.)

Calibrating the Economy Force Sensor

The Economy Force Sensor is designed to produce approximately zero volts when it is “zeroed”. A change in force of one newton causes a change in output voltage of 160 millivolts (0.160 V); **therefore, the sensor does not need to be calibrated.** Instead, the voltage can be converted directly into force. For example, after the sensor is “zeroed”, an output voltage of 0.160 volts equals a force of one newton, a voltage of 1.60 volts equals a force of 10 newtons, and so on. In the same way, a voltage of -1.60 volts equals a force of -10 newtons (in other words, a pull of 10 newtons).

However, you can calibrate the sensor to learn about the process of calibration. All calibrations assume that the sensor produces an output voltage that is linear with respect to the input signal. Calibration is done by setting up two calibration situations (such as “no force” and a known force), measuring the input signal in each situation in comparison to a known standard, and entering the readings.

General Calibration Procedure:

1. In your data acquisition software, open the Force Sensor’s calibration dialog.
2. Place your Force Sensor in the lowest force situation for which you are calibrating (such as, no force).
3. Press the tare button to “zero” the Force Sensor.
4. In the calibration dialog, type the low value into the LOW VALUE text box, and click the READ button.
5. Apply a known force to the Force Sensor (for example, hang a mass of known weight from the detachable hook). This force should be approximately that of the highest force you plan to measure.
6. Type the value for the applied force in the HIGH VALUE text box, and click the READ button.

Suggested Experiments

Component of Force on an Inclined Plane

When a cart is at rest on an inclined plane, the component of force acting on the cart that is parallel to the plane is $mg\sin\theta$, where mg is the weight of the cart and θ is the angle of the plane. Use the sensor to measure the weight of a Dynamics Cart. Mount the sensor at the high end of the inclined Dynamics Track using an Accessory Bracket (CI-6545), and connect it to a Dynamics Cart on the track with a string. Measure the angle of the track. Measure the tension in the string, and compare this to the theoretical value $mg\sin\theta$.

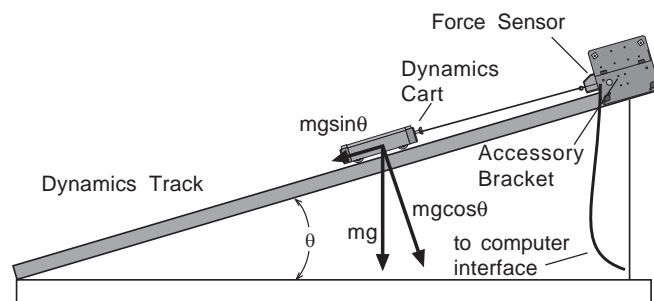

Newton’s Second Law: Pushing and Pulling a Cart

When an object is accelerated by a net force, the acceleration is directly proportional to the net force and inversely proportional to the object’s mass. Mount the Force Sensor onto a Dynamics Cart. Use a Motion Sensor to measure the velocity and acceleration of the cart. Zero the Force Sensor. Hold the hook on the front of the Force Sensor, and move the cart gently but irregularly back and forth in front of the Motion Sensor. Use the computer program to compare the measured force to the measured velocity and acceleration.

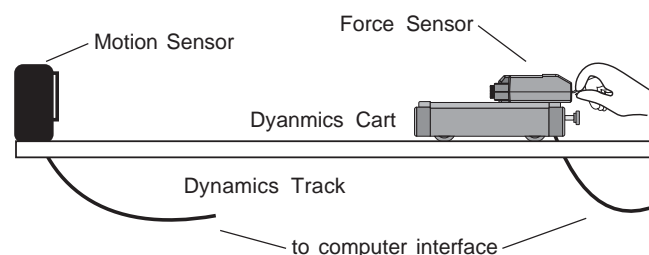

Newton’s Second Law: Constant Force

What happens if the cart is pulled by a constant force? Arrange the Motion Sensor, Force Sensor, and cart on the track as in the previous suggested experiment. Set up a Super Pulley (ME-9450), string, and hanging mass so that the cart/Force Sensor will be pulled by the string attached to the hanging mass. Use the Motion Sensor to measure the velocity and acceleration of the cart as it is pulled by the string. Use the computer program to compare the measured force to the measured velocity and acceleration.

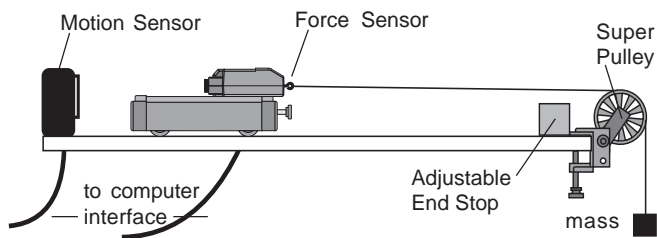

Change the hanging mass and repeat the experiment.

Work-Energy Theorem: $W = \Delta KE$

What happens to the kinetic energy of the cart as it is pulled by a constant force? Arrange the Motion Sensor, Force Sensor, and cart on the track as in the previous suggested experiment. Set up a Super Pulley (ME-9450), string, and hanging mass so that the cart/Force Sensor will be pulled by the string attached to the hanging mass. Use the Motion Sensor to measure the change in position and the velocity of the cart as it is pulled by the string. Use the computer program to find the integration under the curve of a force versus distance graph. Use the program to calculate the amount of kinetic energy gained by the cart. Compare the calculated value of the work to the calculated value of the final kinetic energy.

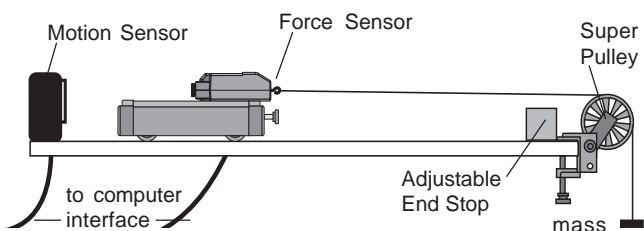

Tension

What is the tension in the string in the previous suggested experiment? Arrange the Force Sensor and cart on the track as in the previous suggested experiment. Set up a Super Pulley, string, and hanging mass so that the cart/Force Sensor will be pulled by the string attached to the hanging mass. First, hold the cart at rest so the tension in the string is “mg” (the hanging mass times the acceleration due to gravity). Then, let go of the cart so it accelerates toward the pulley. Use the program to measure the amount of force in the string. The tension should be constant, but less than “mg”.

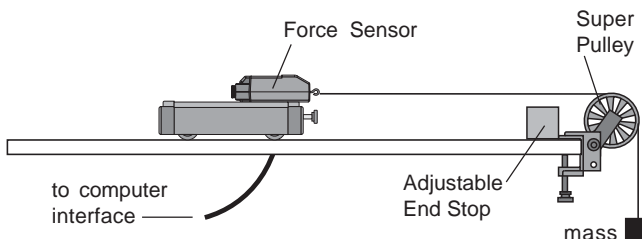

Newton’s Second Law: Friction

Make observations when a force is applied to the cart/ Force Sensor and compare its acceleration when no friction is present to the acceleration when friction is added. You will need to add the Friction Cart Accessory (ME-9457) to the Dynamics Cart. Arrange the Motion Sensor, Force Sensor, and “friction” cart on the track as in the previous suggested experiment.

Set up a Super Pulley, string, and hanging mass so the cart/Force Sensor will be pulled by the string attached to the hanging mass. Adjust the friction cart accessory so the friction pad is not in contact with the track. Accelerate the cart with a 50 gram mass. Use the Motion Sensor to measure the velocity and acceleration of the cart as it is pulled by the string.

Use the computer program to compare the measured

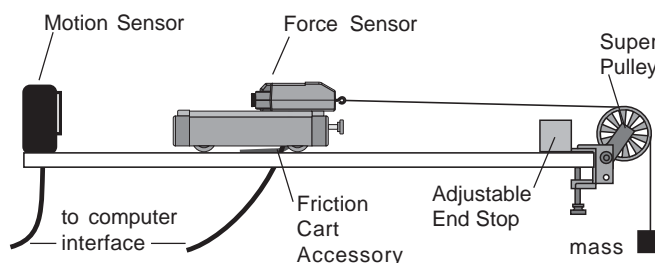

force to the measured velocity and acceleration. Adjust the friction pad on the bottom of the cart until it is rubbing against the track just enough to cause the cart to move with a constant velocity as the 50 gram mass falls. Use the Motion Sensor and the computer program to analyze the force, velocity, and acceleration. Finally, raise the friction pad so it rubs the track slightly less than before, and repeat the measurements.

Newton's Third Law

“For every action, there is an opposite but equal reaction.” Whenever one object exerts a force on a second object, the second object exerts an equal and opposite force on the first. Use two Force Sensors. Set up the computer program so that a push will be negative for one of the sensors. Hook the two sensors together, and use the computer program to measure the force from both Force Sensors as you pull one Force Sensor with the second Force Sensor.

Newton's Third Law: Impulse/Collision

The impulse during a collision equals the change in momentum during the collision:

$$F\Delta t = \Delta mv$$

Mount the Force Sensor at one end of the track. Arrange the cart and Motion Sensor so the Motion Sensor can measure the motion of the cart as it is pushed toward the Force Sensor, collides with it, and rebounds. Use the computer program to determine the impulse and the change in momentum during the collision.

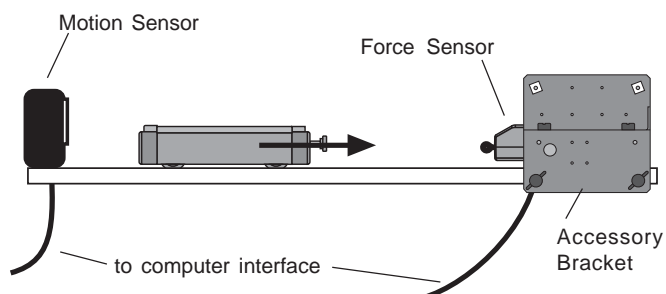

Other Suggested Experiments

- Measure the force of a fan cart.
- Measure the centripetal force of a swinging pendulum, and compare the force to the speed, length, and mass of the pendulum.
- Measure the change in mass of liquid nitrogen as it vaporizes versus the energy input to vaporize the liquid nitrogen.
- Measure fluid drag forces on objects of various shapes in a wind tunnel.
- Measure the net force acting on a pair of harmonic oscillators.
- Study damped and undamped harmonic motion using a mass and spring system.

Specifications

Output voltage:	+8V for +50 newtons (pushing) -8 V for -50 newtons (pulling)
Output noise:	±2 millivolts
Force slew rate:	30 newtons/millisecond
Bandwidth limit:	2 kilohertz (internal low pass filter)
Output drive:	12 meters of cable without instability.
Beam deflection:	0.28 mm

Note: This instruction sheet was written assuming the user knows how to operate the data acquisition software used with the *ScienceWorkshop* Computer Interface. Please see the appropriate printed manuals or online help for specific instructions.

Limited Warranty

PASCO scientific warrants the product to be free from defects in materials and workmanship for a period of one year from the date of shipment to the customer. PASCO will repair or replace, at its option, any part of the product which is deemed to be defective in material or workmanship. The warranty does not cover damage to the product caused by abuse or improper use. Determination of whether a product failure is the result of a manufacturing defect or improper use by the customer shall be made solely by PASCO scientific. Responsibility for the return of equipment for warranty repair belongs to the customer. Equipment must be properly packed to prevent damage and shipped postage or freight prepaid. (Damage caused by improper packing of the equipment for return shipment will not be covered by the warranty.) Shipping costs for returning the equipment after repair will be paid by PASCO scientific.

Address: PASCO scientific
10101 Foothills Blvd.
Roseville, CA 95747-7100

Phone: (916) 786-3800
FAX: (916) 786-8905
e-mail: techsupp@pasco.com
web: www.pasco.com

Feedback

If you have any comments about the product or manual, please let us know. If you have any suggestions on alternate experiments or find a problem in the manual, please tell us. PASCO appreciates any customer feedback. Your input helps us evaluate and improve our product.

Contacting Technical Support

Before you call the PASCO Technical Support staff, it would be helpful to prepare the following information:

- ▶ If your problem is computer/software related, note:
 - Title and revision date of software;
 - Type of computer (make, model, speed);
 - Type of external cables/peripherals.
- ▶ If your problem is with the PASCO apparatus, note:
 - Title and model number (usually listed on the label);
 - Approximate age of apparatus;
 - A detailed description of the problem/sequence of events (in case you can't call PASCO right away, you won't lose valuable data);
 - If possible, have the apparatus within reach when calling to facilitate description of individual parts.
- ▶ If your problem relates to the instruction manual, note:
 - Part number and revision (listed by month and year on the front cover);
 - Have the manual at hand to discuss your questions.

To Reach PASCO

For technical support, call us at 1-800-772-8700 (toll-free within the U.S.) or (916) 786-3800.

fax: (916) 786-3292

e-mail: techsupp@pasco.com

web: www.pasco.com